

LOAD SENSING ADJUSTMENT

THIS MODEL INCORPORATES A LOAD-SENSING FEATURE IN THE OPEN DIRECTION. IF THE GRILLE/GATE IS OBSTRUCTED OR LOCKED WHILE OPENING THEN THE LOAD-SENSING FEATURE WILL ACTIVATE AND STOP GRILLE/GATE MOVEMENT. UPON ACTIVATION OF LOAD-SENSING FEATURE, YOU MUST INITIATE A CLOSE COMMAND TO RESET THE SYSTEM.

NOTE: SPRING TENSION ADJUSTMENT WING NUT MUST BE ADJUSTED PER INSTALLATION, FACTORY ADJUSTMENT IS STRICTLY FOR OPERATOR TESTING ONLY.

ADJUSTMENT CONDITIONS

1. FOR LARGER OR HEAVIER GRILLES/GATES
IF GRILLE/GATE EXPERIENCES A JERKING MOTION DURING OPENING DIRECTION, OR WILL NOT INITIATE OPEN MOTION AT ALL, THEN TURN WING NUT AT SPRING TENSION ADJUSTMENT ROD CLOCKWISE (ONE TURN AT A TIME). THIS INCREASES SPRING TENSION ON LOAD SENSING FEATURE TO BE LESS SENSITIVE.
2. FOR SMALLER/LIGHTER GRILLES/GATES
IF GRILLE/GATE WILL NOT RESPOND BY WAY OF THE LOAD SENSING FEATURE THEN IT MAY BE NECESSARY TO TURN TURN WING NUT AT SPRING TENSION ADJUSTMENT ROD COUNTER-CLOCKWISE (ONE TURN AT A TIME). THIS DECREASES SPRING TENSION ON LOAD SENSING FEATURE TO BE MORE SENSITIVE
3. CHAIN TENSION ADJUSTMENT BOLT
THIS IS A PRE-SET FACTORY SETTING THAT LIMITS THE MOVEMENT OF SPRING ADJUSTMENT BRACKET AND SHOULD NOT BE ADJUSTED.
4. EJ/EHJ CUTOUT SWITCH
THE CUTOUT SWITCH CAN BE RAISED OR LOWERED BY LOOSENING THE 2 CUTOUT SWITCH HEIGHT ADJUSTMENT BOLTS AND RAISING/LOWERING USING THE BOLT SPACERS (KNOBS). SHOULD NOT NEED TO BE ADJUSTED IN THE FIELD.

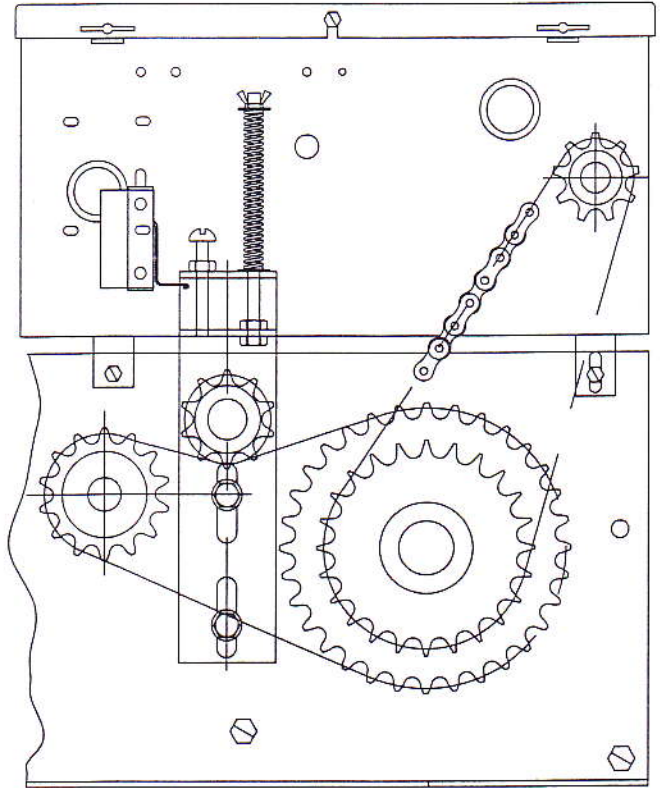

CUTOUT SWITCH HEIGHT ADJUSTMENT DOUBLE NUT

CUTOUT SWITCH

CUTOUT SWITCH DOUBLE SPACES

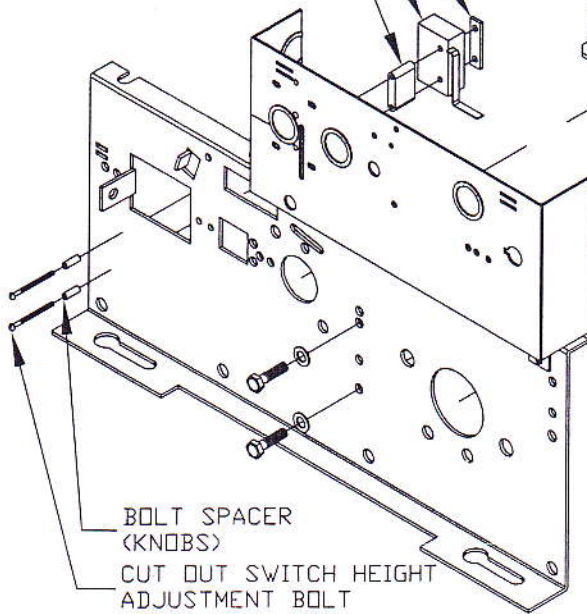

BOLT SPACER (KNOBS)

CUT OUT SWITCH HEIGHT ADJUSTMENT BOLT

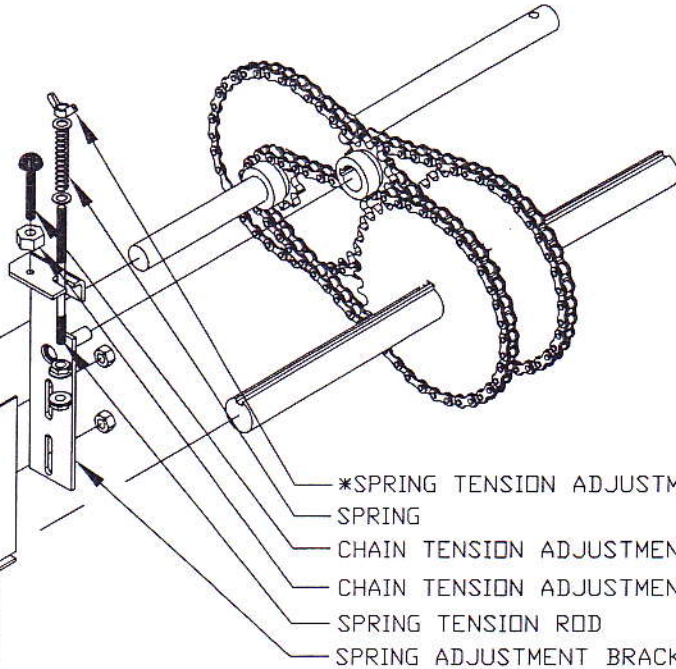

- *SPRING TENSION ADJUSTMENT WING NUT
- SPRING
- CHAIN TENSION ADJUSTMENT BOLT
- CHAIN TENSION ADJUSTMENT NUT
- SPRING TENSION ROD
- SPRING ADJUSTMENT BRACKET

10.03.10	C.S.	D.J.	MICANAN SYSTEMS INC.		
DATE:	APPROVED:	DRAWN BY:	TITLE		
UNLESS OTHERWISE SPECIFIED DIMENSIONS ARE IN INCHES TOLERANCES .XX±.01 ANGLES=±30°			PRO-EJ/EHJ 2010 LOAD SENSING ADJUSTMENT		
		MATERIAL	WEIGHT lb	SIZE A	
REVISION:A		CAD FILE: PRO-EJ/EHJ LOAD SENSING ADJUSTMENT.CAD	SCALE:	PAGE 1/1	