

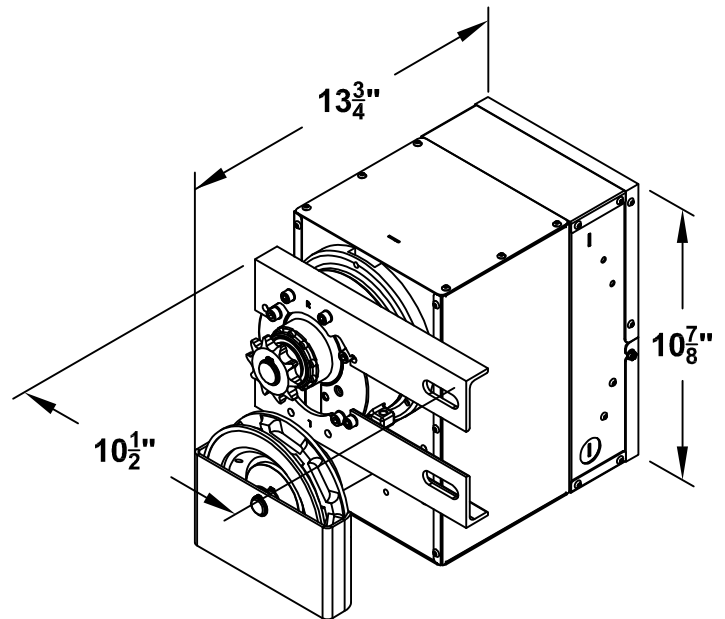

FD-2A/FD-3A FIRE DOOR OPERATOR

AUTOMATIC RESETTING CHAIN AND CRANK OPERATOR

- **MULTIVOLTAGE INPUT
24VAC, 24VDC OR 120VAC**
- **LOW POWER CONSUMPTION -
BACKUP POWER CAN BE PROVIDED
FROM FIRE ALARM CONTROL PANEL**
- **NO DELAY TO REENGAGE CLUTCH**
- **FULL SIZE TERMINAL STRIP**
- **MULTIPLE KNOCKOUTS FOR
CONNECTION FLEXIBILITY**
- **FUSE PROTECTED CIRCUITS**
- **BUILT IN GOVERNOR**
- **FIELD REVERSIBLE HANDING**
- **#40 ROLLER CHAIN DRIVE ON DOOR**
- **FAILSAFE CONSTANTLY ENERGIZED
SOLENOID MECHANISM**
- **10 SECOND DELAY ON ACTIVE
ALARM OR POWER LOSS**
- **BUILT IN GOVERNOR LIMITS DOOR
CLOSING SPEED TO 12" PER SECOND
ON POWER LOSS OR ALARM**
- **CLOSE WARNING DEVICE AVAILABLE
WHEN UNIT IS POWERED BY FIRE
ALARM CONTROL PANEL.**



CHAIN OPERATION (FD-2A)

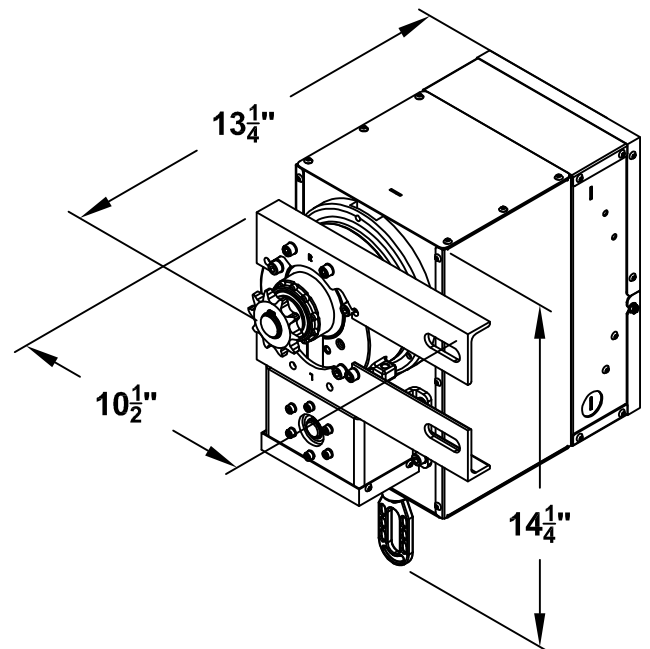

CRANK OPERATION (FD-3A)

**NOTE: WHEN MOUNTED WITHIN 8 FEET
OF FLOOR A COVER IS REQUIRED PER UL325**