



# FD-2A FIRE DOOR OPERATOR

## AUTOMATIC RESETTING CHAIN AND CRANK OPERATOR

### ELECTRICAL FEATURES:

- **MULTIVOLTAGE INPUT**  
**24VAC, 24VDC OR 120VAC**
- **LOW POWER CONSUMPTION -**  
**BACKUP POWER CAN BE PROVIDED**  
**FROM FIRE ALARM CONTROL PANEL**
- **NO DELAY TO REENGAGE CLUTCH**
- **POWER INDICATOR LED**
- **FULL SIZE TERMINAL STRIP**
- **MULTIPLE KNOCKOUTS FOR**  
**CONNECTION FLEXIBILITY**
- **FUSE PROTECTED CIRCUITS**

### MECHANICAL FEATURES:

- **PRECISION FRICTION DISK CLUTCH**
- **CAM ACTUATED LOAD HOLDING BRAKE**
- **SEALED BALL BEARINGS ON MAIN SHAFTS**
- **8:1 REDUCTION RATIO**
- **FIELD REVERSIBLE HANDING**
- **STANDARD Ø1-1/4" VISCOUS GOVERNOR(S)**  
**MOUNTS DIRECTLY ON HOIST FRAME**
- **#40 ROLLER CHAIN DRIVE ON DOOR**
- **VERTICALLY MOUNTED ON DOOR BRACKET**  
**OR DIRECTLY ON WALL**

**NOTE: WHEN MOUNTED WITHIN 8 FEET**  
**OF FLOOR A COVER IS REQUIRED PER UL325**

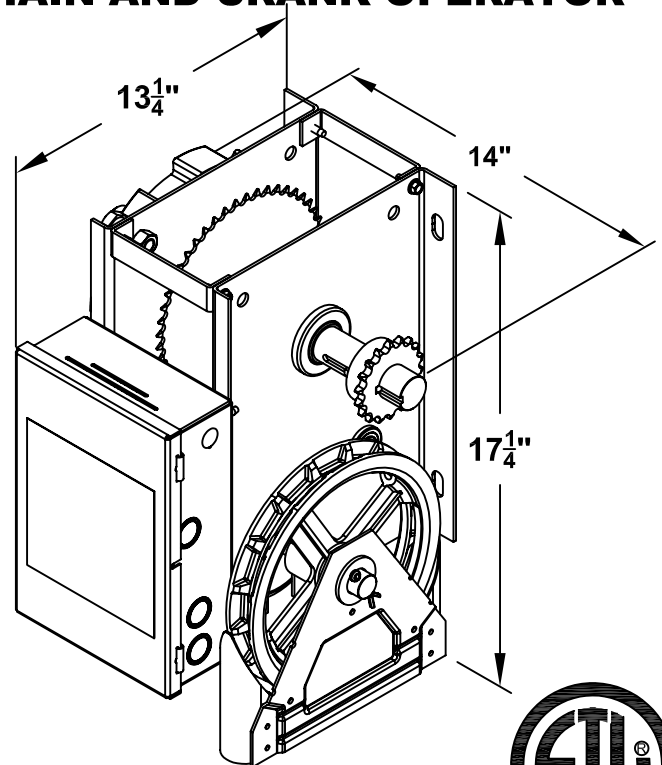

**CHAIN OPERATION**



US  
RECOGNIZED COMPONENT  
CONFORMS TO UL 325  
3040233

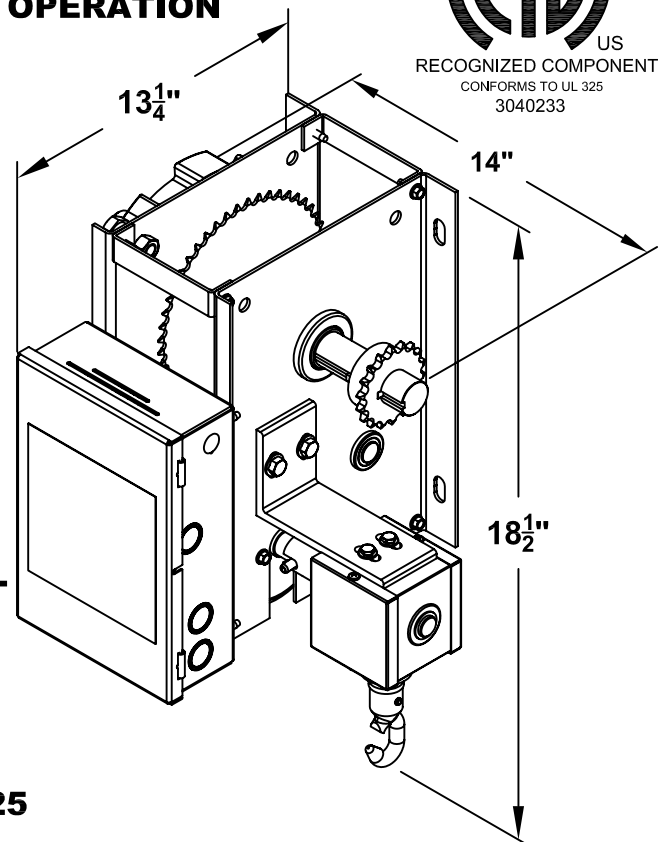

**CRANK OPERATION**