



# **SIMPLE-TEST® MANUAL OPERATOR**

**Hand Chain (Model FCF)  
&**

**Hand Crank (Model FKF)**

**INSTRUCTION MANUAL**

## **WARNING**

1. CAUTION: Review all installation instructions, procedures, cautions and warnings contained within this manual prior to installing and/or servicing this product. Maximum fire protection is provided when installed in accordance with factory specifications with provided fuse link systems.
2. Installation and testing to factory specifications shall be performed by factory authorized personnel for proper operation in accordance with all of the latest National Fire Protection Association (NFPA), Underwriters Laboratories (UL), National Electrical Code (NEC), local, state, county, district and/or other applicable building and fire standards, guidelines, regulations and codes including, but not limited to, all appendices and amendments and the requirements of the local Authority Having Jurisdiction (AHJ).
3. Installation to be performed by factory authorized door system technicians only.
4. Clear fire door opening and prohibit all traffic through door opening during system testing!

## **INTRODUCTION**

The closing system is designed to be used in conjunction with a temperature activated fusible link arrangement. It is designed for use on rolling fire doors and counter fire doors. Optionally, the unit is designed to accept a bolt-on, fail-safe floor level reset or automatic reset release device for connection to local detectors or a central alarm system.

## **IMPORTANT MECHANICAL INSTALLATION PROCEDURE**

### **WARNING - To reduce the risk of severe injury or death:**

1. READ AND FOLLOW ALL INSTALLATION INSTRUCTIONS.
2. Spring tension must be adjusted to allow the fire door to self close during a drop test. A door that is operating improperly could cause severe injury. Have qualified door system technicians make repairs to spring assemblies and other hardware before installing the operator.
3. Cover any exposed, moving operator parts that are less than 8 feet above the floor.
4. When utilized, locate the “push to close” control station: (a) within sight of the door, (b) at a minimum height of 5 feet so small children cannot reach it, and (c) away from all moving parts of the door.
5. Instruct the end user on proper operation of the operator.
6. The door is under extreme spring tension. Have qualified door system technicians make all necessary adjustments and repairs to the door.
7. When utilized, read and understand the wiring diagram of the alarm release device box.
8. For products having a manual release, instruct the end user on the operation of the manual release.

# INSTALLATION INSTRUCTIONS

## INSTALLATION POSITIONS

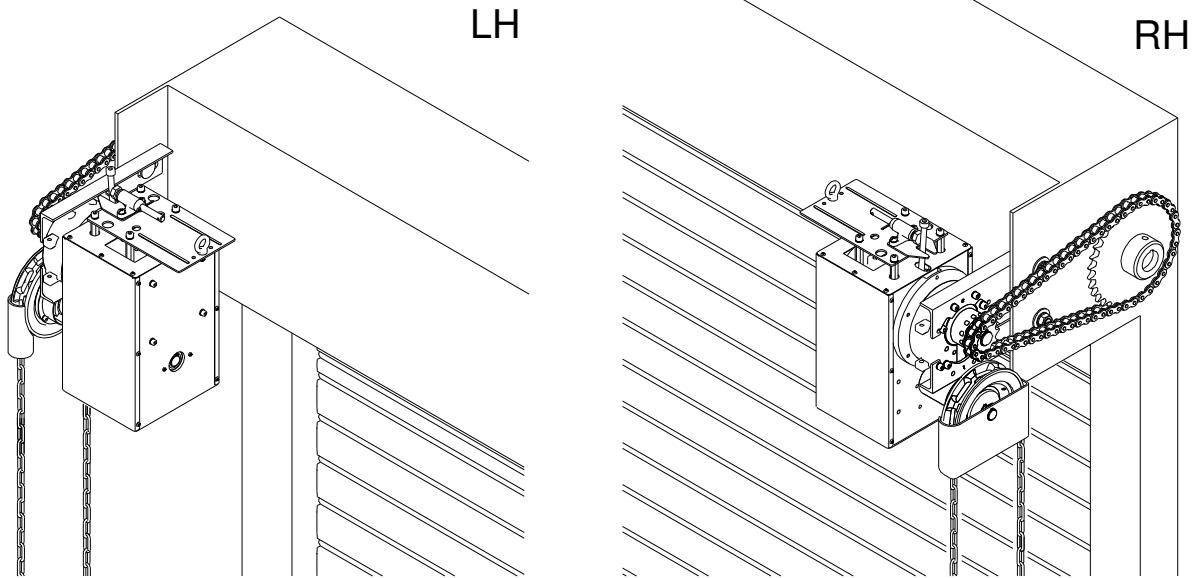

(Installation Illustration for FCF)

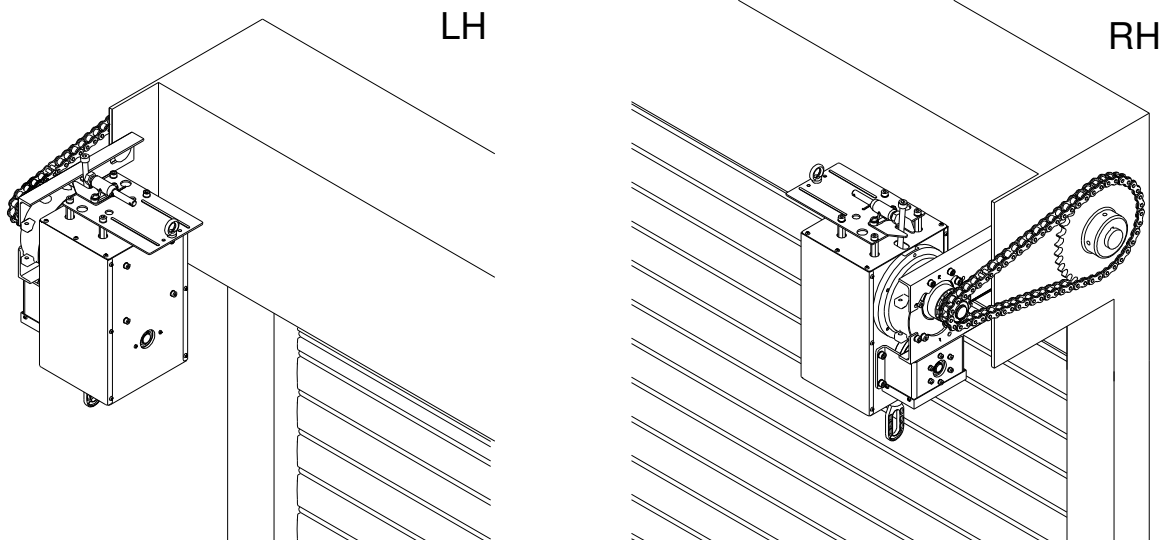

(Installation Illustration for FKF)

***Consult factory for changes in installation positions.***

## OPERATOR MOUNTING

1. Before the operator is installed, verify that the door is properly operating and balanced.
2. Make sure the mounting plates are correctly positioned for RH or LH mounting.
3. Attach and tighten the mounting hardware to the mounting plate.
4. Tighten the operator mounting plate to the door.

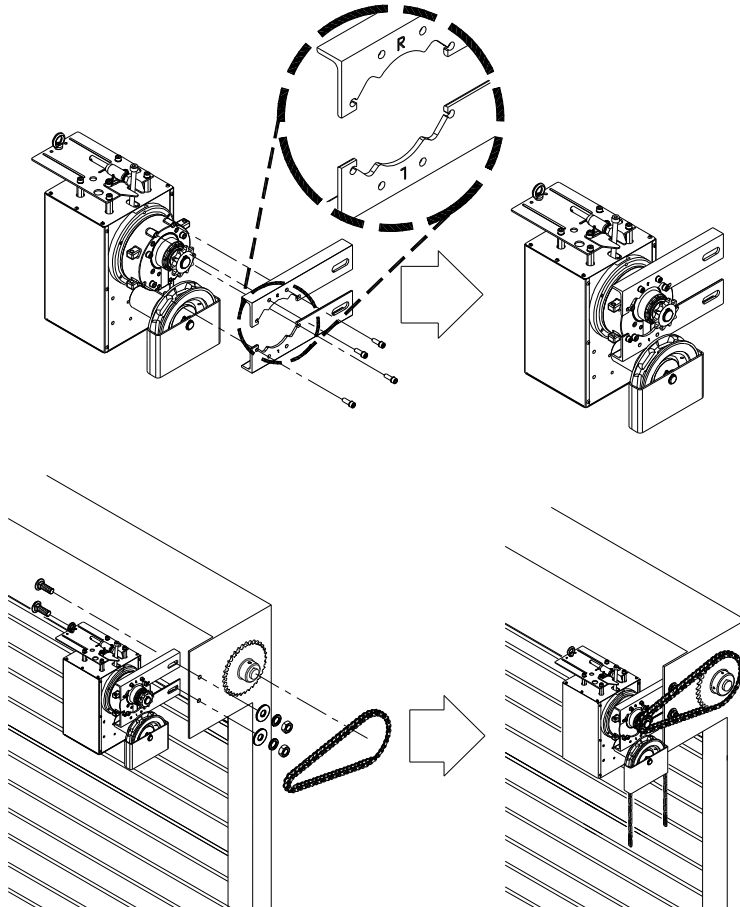

5. When the operator is mounted on the bracket, be sure the door sprocket is properly aligned / in the same plane with the operator drive sprocket before securing to the shaft.
6. The shelf or bracket must provide adequate support for the operator. Prevent play between operator and door shaft. Permit operator to be fastened securely and with the drive shaft parallel to the door shaft.

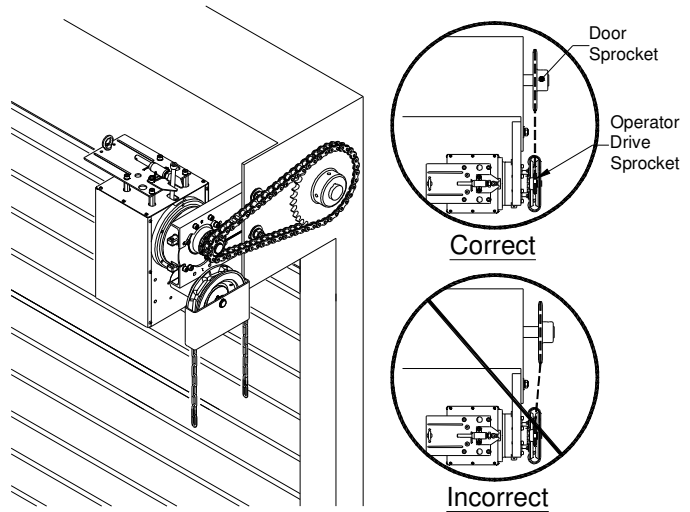
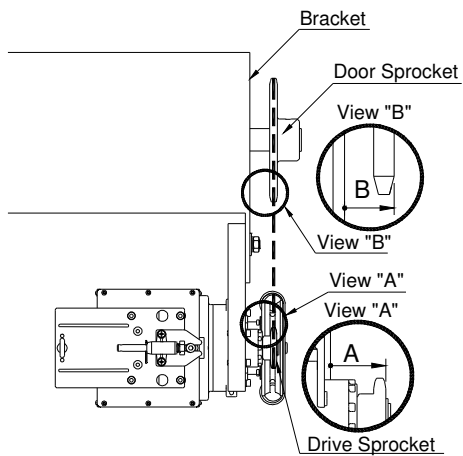

\* Chain hoist shown. Hand crank similar.

## ADJUSTING THE DRIVE CHAIN

**NOTE: Use correct type, size and proper length of roller chain.**

1. Adjust the drive chain by tilting or move the operator so that there is about 1/4" of slack when the chain is depressed.
2. Once the drive chain has been tightened, then tighten the operator mounting screws.

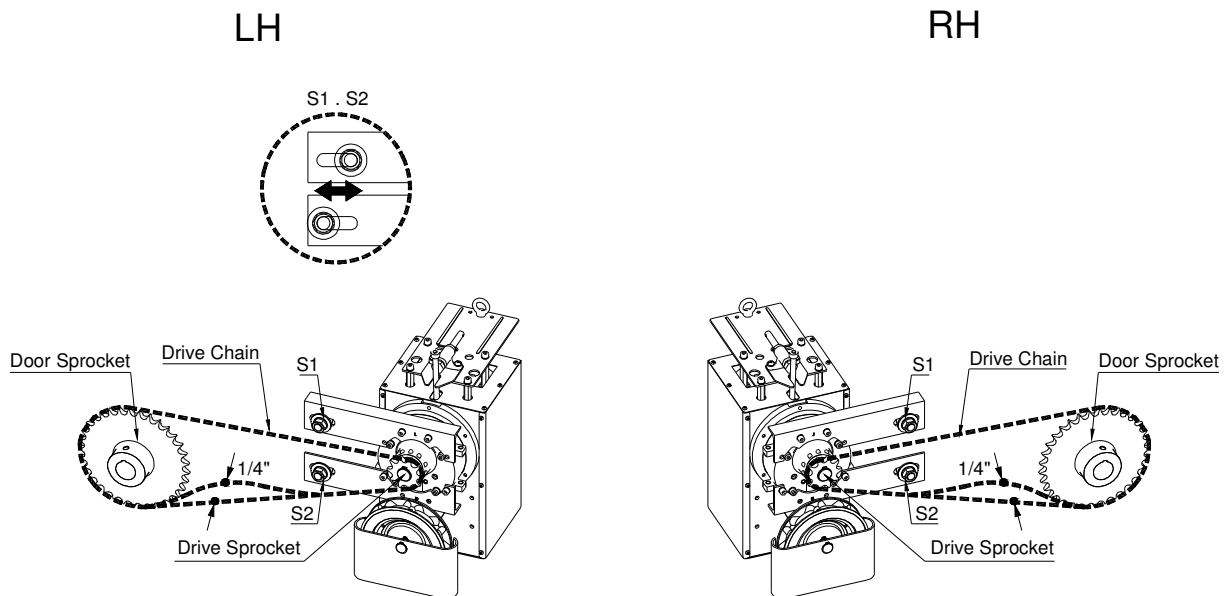

## **ADJUSTING OPERATING CHAIN LENGTH (FCF units only)**

Operating chain is provided in a standard length. Depending on door height, the chain may need to be shortened or lengthened. A DIFFERENT COLOR connecting link can be found in the hand chain. Use this link for breaking the chain to make adjustments to the hand chain length so that the bottom of the hanging chain is 2' to 3' above the floor.

## **CHAIN HOLDER**

Install at a convenient location.

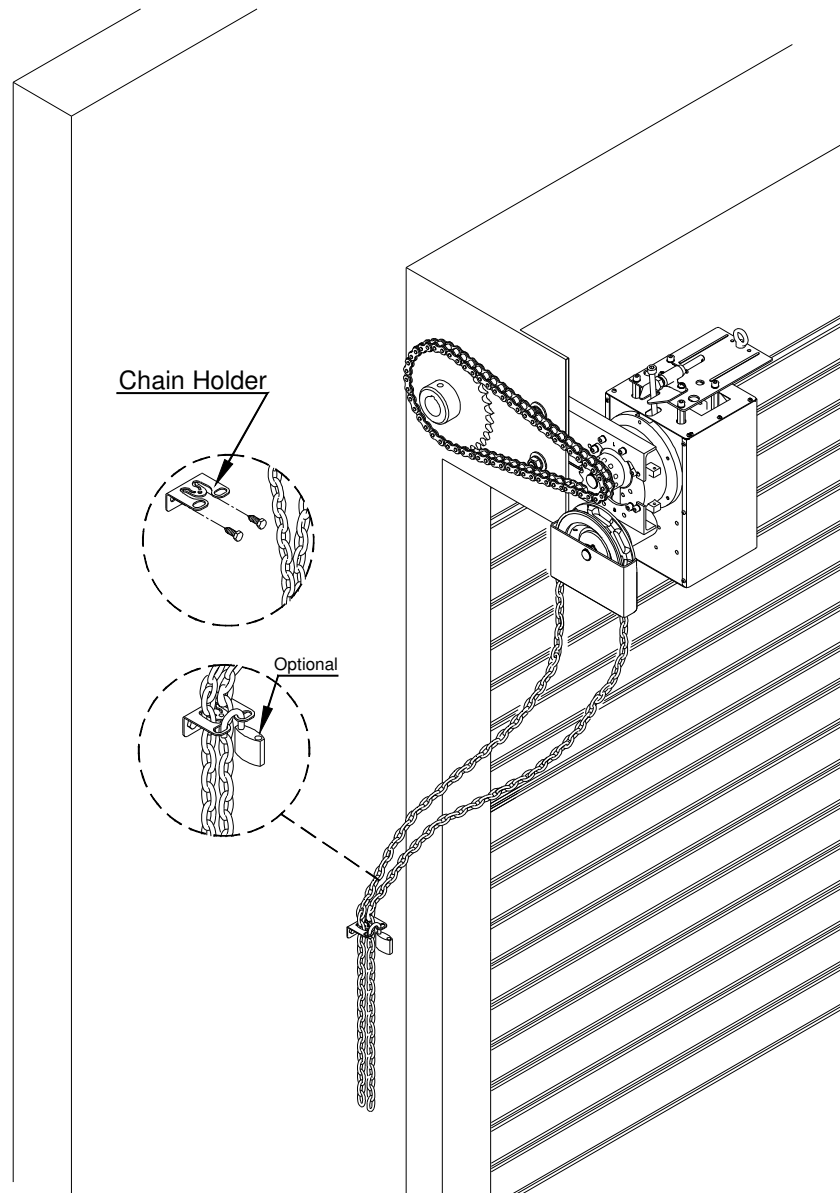

## **IMPORTANT SAFETY INSTRUCTIONS**

**WARNING – To reduce the risk of severe injury or death:**

1. READ AND FOLLOW ALL INSTRUCTIONS.
2. Never let children operate or play with door controls.
3. Personnel should keep away from a door in motion and keep the moving door in sight until it is completely closed or opened. **NO ONE SHOULD CROSS THE PATH OF A MOVING DOOR.**
4. **KEEP DOORS PROPERLY OPERATING AND BALANCED.** See Door Manufacturer's Owner's Manual. An improperly operating or balanced door could cause severe injury or death. Have trained door systems technician make repairs to cables, spring assemblies, and other hardware.
5. **SAVE THESE INSTRUCTIONS.**

## **OPERATING INSTRUCTIONS**

FCF – Pull operating chain to open and close door. To stop door, let go of the chain.

FKF – Turn crank to open and close door. To stop door, stop turning.



## **FUSIBLE LINK CONNECTION**

### **❖ REMOVE COTTER PIN FROM RELEASE ASSEMBLY.**

Consult NFPA-80 and the authority having jurisdiction for fusible link location(s) and method.

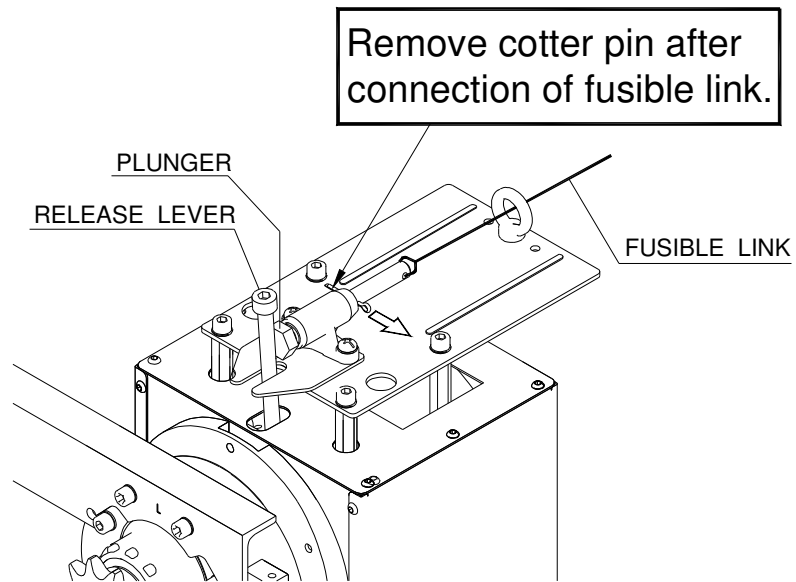

## **MAINTENANCE INSTRUCTIONS**

3148(0) ECN 1131 BY RG 7/27/11

The brake is a self-adjusting brake. It is maintenance free. The brake assembly requires no additional adjustment during its lifetime.



**WARNING**

**If optional alarm release box is used, then disconnect alarm power supply to the alarm release box before servicing.**

Check the following items at the intervals listed:

CHECK LIST	DESCRIPTION	EVERY 3 MONTHS	EVERY 6 MONTHS	EVERY 12 MONTHS
Fasteners	Check & tighten as required		●	
Drop-test	Inspect door, drop-test for proper operation and full closure per NFPA-80			●

- ❖ Inspect and service whenever a malfunction is observed or suspected.
- ❖ Before servicing, always disconnect power supply to the alarm release box, if provided.
- ❖ All replacement parts must be obtained from the door manufacturer per NFPA 80.

Testing of the FCF and FKF are independent of, and shall in no way be interpreted as an alternative method of testing the fire alarm system, and/or any other system component employed on the fire door or counter fire door installation. TESTING SHALL BE PERFORMED AND WITNESSED FOR PROPER OPERATION.