

**INSTALLATION INSTRUCTIONS  
AND  
OPERATION MANUAL**

**FS Series  
Rolling Fire Door Operators**

**UL325-2010 Compliant**

**Restricted Duty Operators**

**U.S. GEAR CORPORATION**

# **IMPORTANT INSTALLATION INSTRUCTIONS**

## **WARNING –To reduce the risk of death or serious injury to persons:**

### 1. READ AND FOLLOW ALL INSTALLATION INSTRUCTIONS.

WARNING! – Components under **extreme spring tension** can cause death or serious injury.

2. Install only on a properly operating and balanced door. A door that is operating improperly could cause death or serious injury. Have trained door systems technicians make all necessary adjustments and repairs to the door before installing the operator.

Note: Fire door spring tension must be adjusted per the manufacturer's installation instructions to allow for automatic closing during a drop test, fusible link/alarm activation and/or power failure (Power failure condition only applies to operators capable of fail-safe closing).

3. Remove all pull ropes.
4. Unless the door operator includes an internal lock sensing system, or external electrical interlocks are installed, remove or make all door locks inoperative, or secure locks in the unlocked position to prevent operation with the locks engaged.
5. Install the door operator at least 8 feet or more above the floor if the operator has exposed moving parts. If it is installed less than 8 feet above the floor, any exposed moving parts must be covered or guarded.
6. Do not connect the door operator to the source of power until instructed to do so.
7. Locate the control station (open-close-stop push button, key station, or the like):
  - a) within sight of the door
  - b) at a minimum height of 5 feet above the floor so small children cannot reach it, and
  - c) away from all moving parts of the door.
8. Install the Entrapment Warning Placard next to the control station in a prominent location.
9. Make sure the available power supply to be connected to the operator is of the same voltage, frequency, phase and wattage as indicated on the nameplate of the operator.
10. Read and understand the wiring diagram of the operator and the control station and any other equipment to be connected to the operator.
11. Always disconnect power whenever installing or servicing the door operator or door.

12. All wiring must be permanent and comply with National Electrical Code (NEC) and local code requirements.
13. Any change in mounting position may result in a change of operator rotation and consequently in a change of control functions. Consult factory for any changes.
14. For products having a manual release, instruct the end user on the operation of the manual release.

## SPECIFICATIONS

<b>MOTOR</b>	
Type:	Restricted cycle duty (30 cycles per hour)
Horsepower:	1/3 hp, 1/2 hp, 3/4 hp
Speed:	1700 RPM
Voltage:	115, 230 – 1 phase 208/230, 460 – 3 phase 230 volt 3 phase motor is suitable for use with 208 volts
Current:	See motor nameplate
<b>ELECTRICAL</b>	
Transformer:	24VAC
Wiring Type:	Momentary pressure open, stop, constant pressure close (provided standard), with provision for momentary pressure close*
Limit Adjustment:	Linear driven, fully adjustable screw type cams.
<b>MECHANICAL</b>	
Drive Reduction:	43:1 (1/3 hp & 1/2 hp), 57:1 (3/4 hp)
Output Shaft Speed:	39 RPM (1/3 hp & 1/2 hp), 30 RPM (3/4 hp)
Door Speed:	6 - 8" per sec. average (typical)
Brake:	Solenoid actuated brake
Auxiliary Chain Hoist:	Standard
<b>ENTRAPMENT PROTECTION</b>	
Sensing Edge*:	(Optional) Sensing device attached to the bottom edge of the door.
Non-Contact Device*:	(Optional) Photo eye device.
<p><b>* Per the requirements of UL Standard 325, the door operator is setup for constant pressure to close the door. As an alternative, the door may be provided with a monitored entrapment protection device that will reverse the door upon contact with or detection of an obstruction during closing. Adding an entrapment device would enable momentary close operation.</b></p>	

### Notes:

1. Non-contact device (photo eye) can be used on doors up to 35 ft. wide (or maximum rated range of device if less than 35 ft.). Use a sensing edge to provide entrapment protection on doors over 35 ft. wide.
2. Sensing edge can be used on all doors.

## TYPES AND SIZES OF DOORS

Consult factory for details.

## **INSTALLATION INSTRUCTIONS**

### INSTALLATION POSITIONS (for 1/3 hp, 1/2 hp)

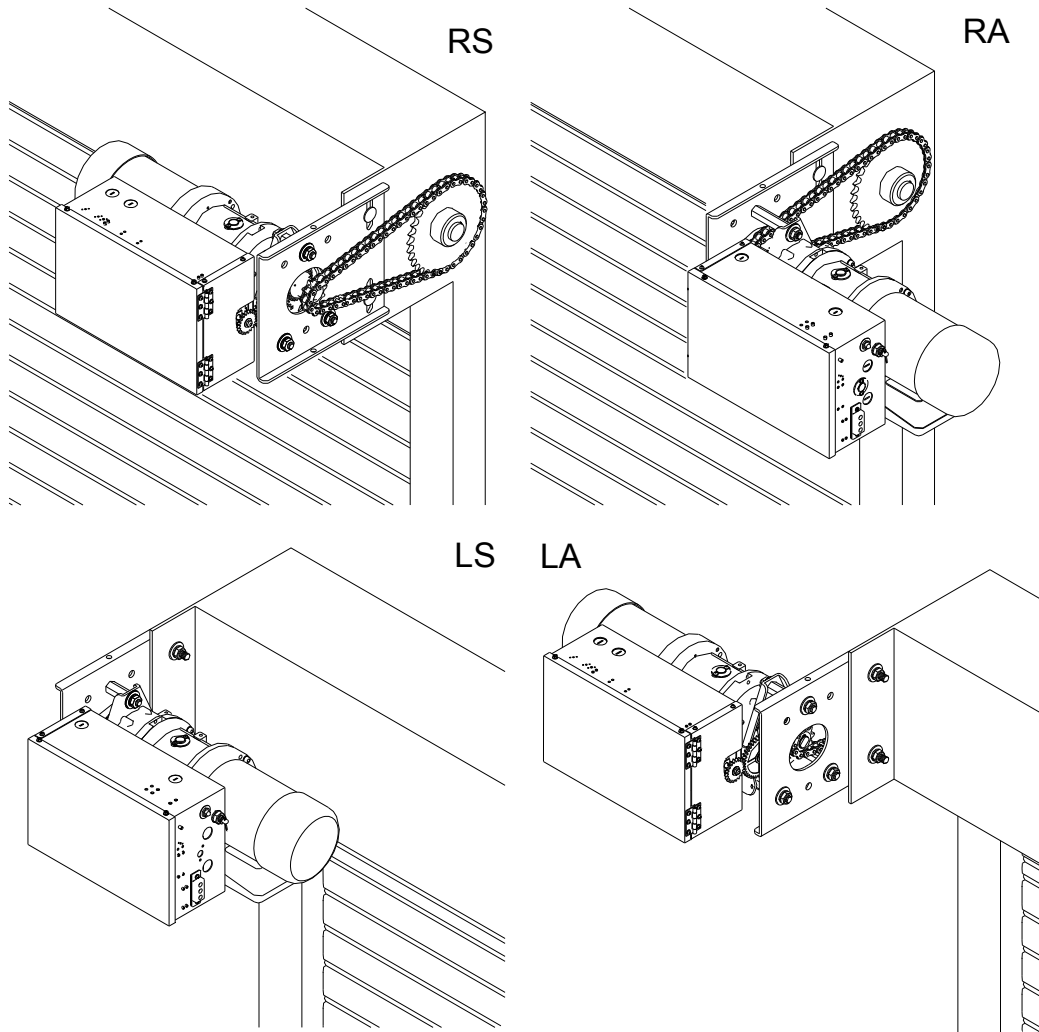

**Consult factory for changes in installation positions.**

**NOTE:** Any change in mounting position may result in a change of operator rotation and consequently in a change of control functions. Consult factory for any changes. (LS and RA mounting positions are LH operators, RS and LA positions are RH operators)

Operators mounted in alternate positions (LA, RA) require the long mounting legs in lieu of the standard short mounting legs.

## **INSTALLATION POSITIONS (for 3/4 hp)**

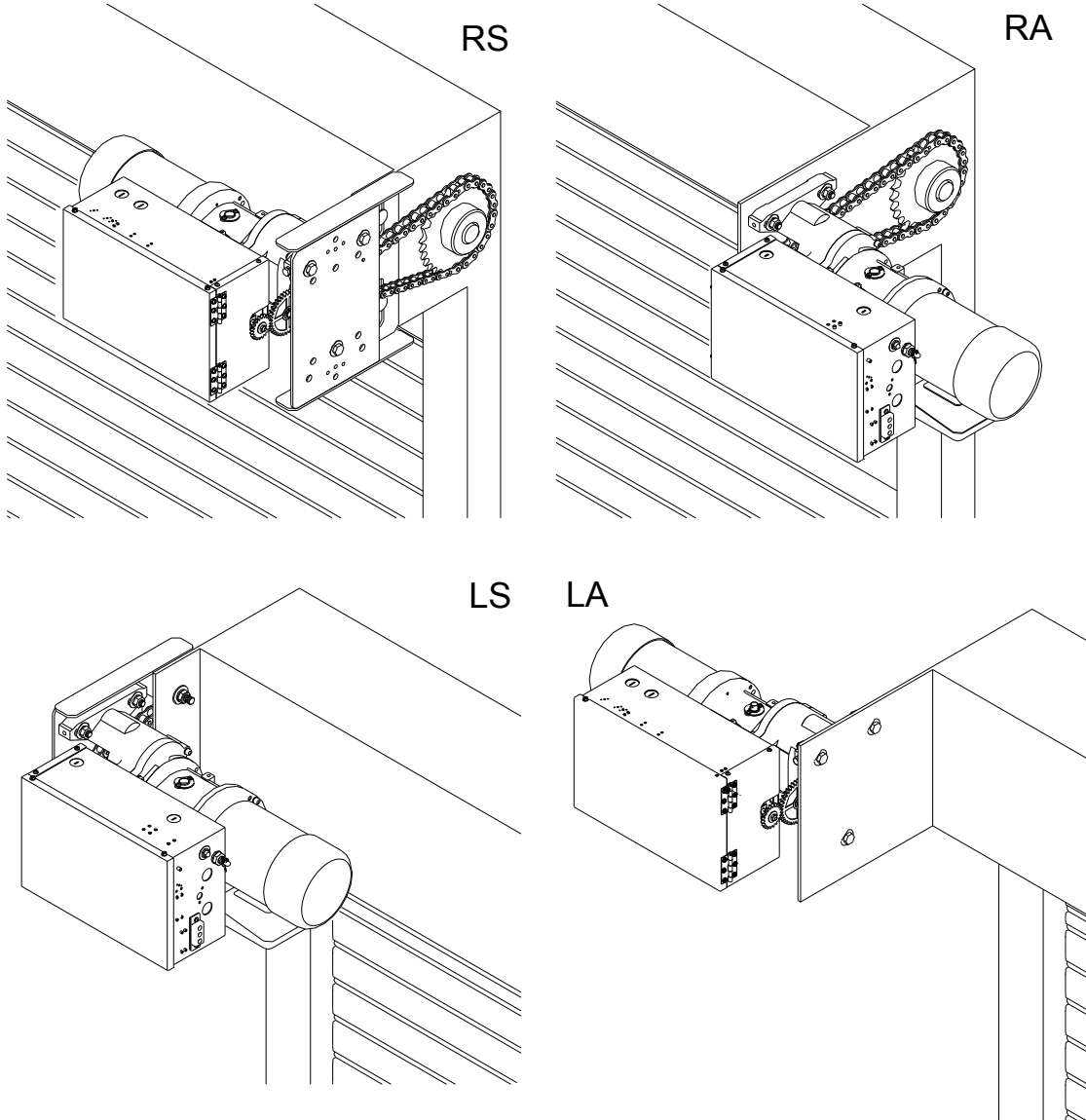

**Consult factory for changes in installation positions.**

**NOTE:** Any change in mounting position may result in a change of operator rotation and consequently in a change of control functions. Consult factory for any changes. (LS and RA mounting positions are LH operators, RS and LA positions are RH operators)

**Operators mounted in alternate positions (LA, RA) require a straight mounting plate in lieu of the standard bent plate.**

## OPERATOR MOUNTING

1. Before the operator is installed, verify that the door is properly operating and balanced.
2. Make sure the layout of the mounting holes on the bracket are correct.
3. Bolt the operator mounting plate to the door bracket plate.
4. Attach and tighten the three mounting legs to the mounting plate (for 1/3 and 1/2 hp only).
5. Mount the operator to the three legs and tighten (for 1/3 and 1/2 hp only). For 3/4 hp, mount the operator base to the mounting plate.

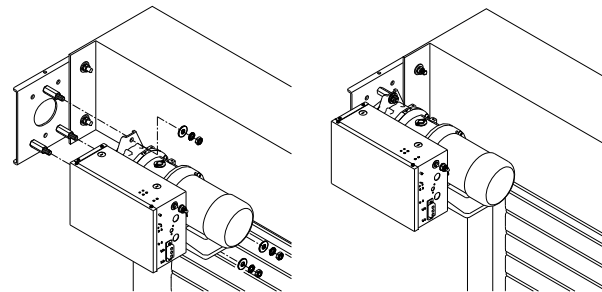
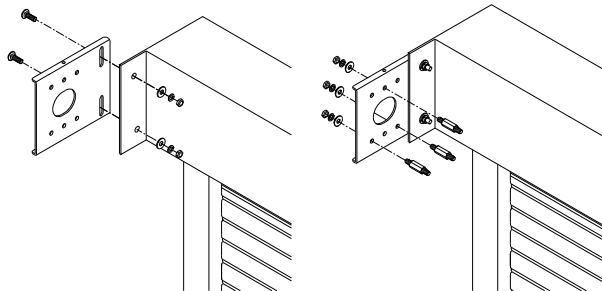

(Figure 1 for 1/3hp and 1/2hp)

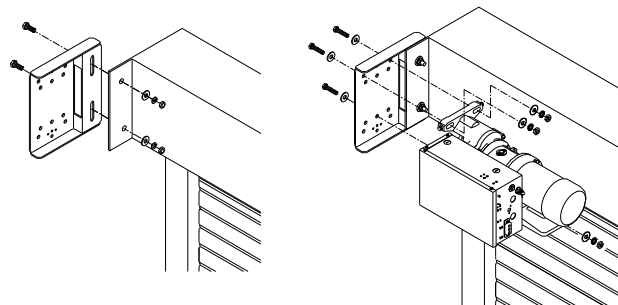

(Figure 2 for 3/4hp)

6. When the operator assembly is attached to the door bracket, be sure the door driven sprocket is properly aligned with the operator drive sprocket before securing the driven sprocket to the shaft. (See Figure 1 for 1/3hp and 1/2hp; see Figure 2 for the 3/4hp)
7. The shelf or bracket must provide adequate support for the operator. Prevent play between the operator and the door shaft. The operator must be securely attached with the drive shaft parallel to the door shaft. It may be necessary to field brace the operator/bracket.

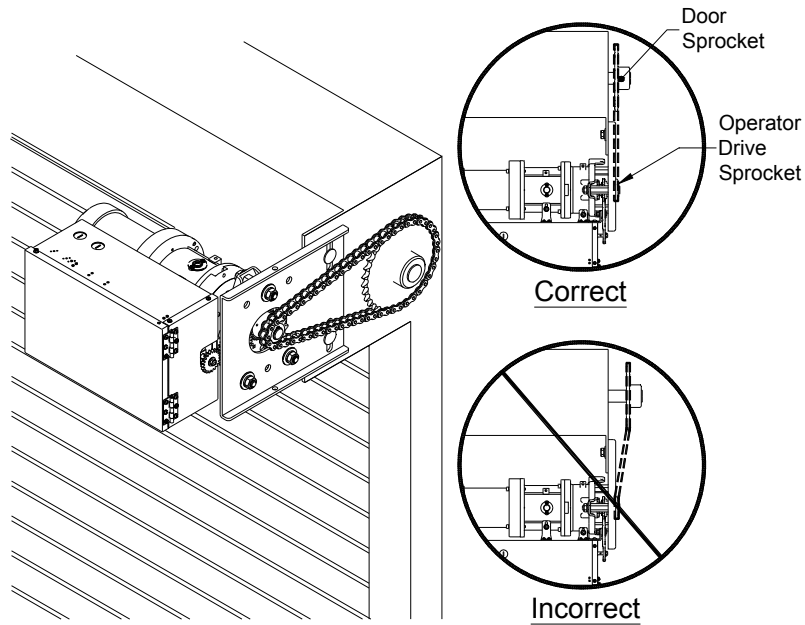

(Figure 1 for 1/3hp and 1/2hp)

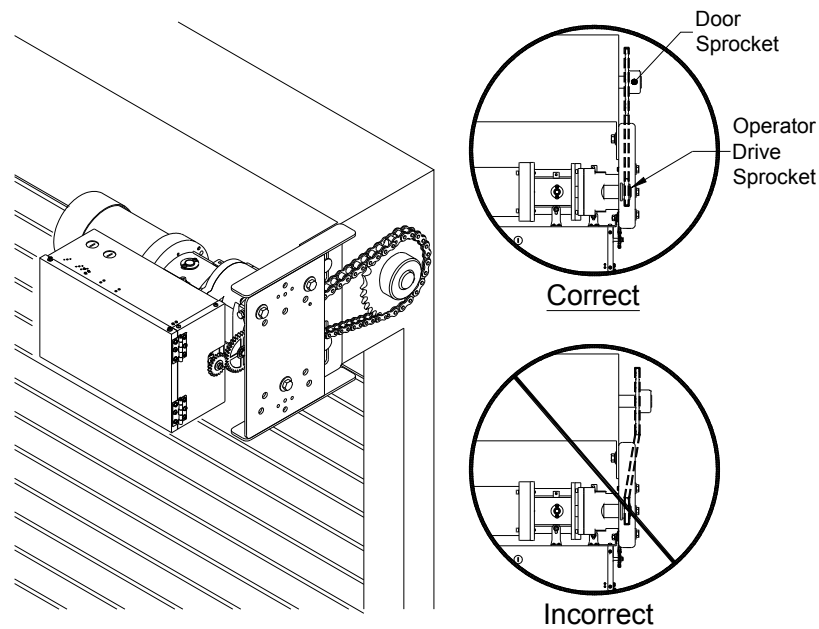

(Figure 2 for 3/4hp)

## DRIVE CHAIN ADJUSTMENT

**NOTE: Use correct type, size and proper length of roller chain.**

1. Adjust the drive chain by tilting or move the operator so that there is about 1/4" of slack when the chain is depressed.

Note: The set screw included in the operator may be used for adjustment. (See figure 1- S1 location for 1/3hp and 1/2hp), (See figure 2 - T1, T2, T3, T4 for 3/4hp).

2. Once the drive chain has been tightened and the base leg screws have been set, and then tighten the operator screws.

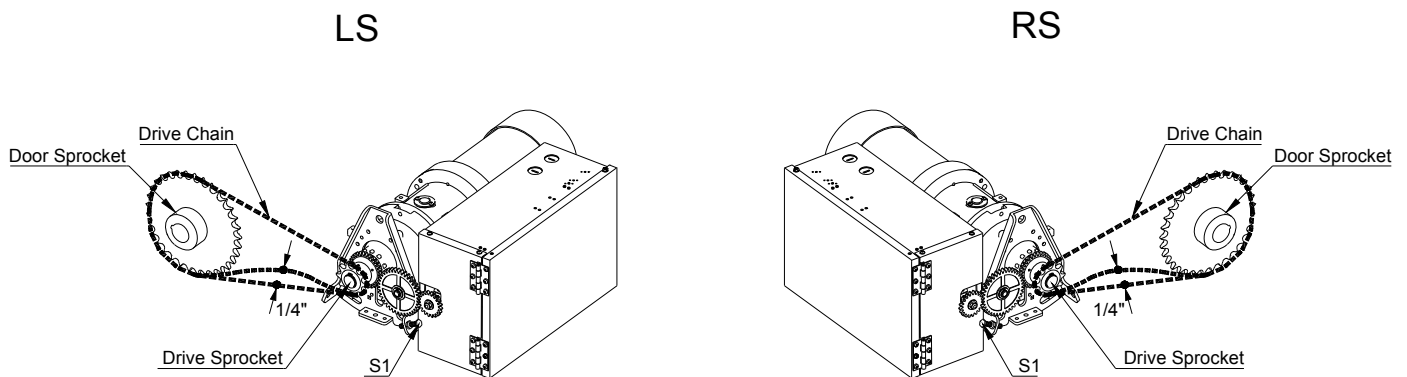

(Figure 1 for 1/3hp and 1/2hp)

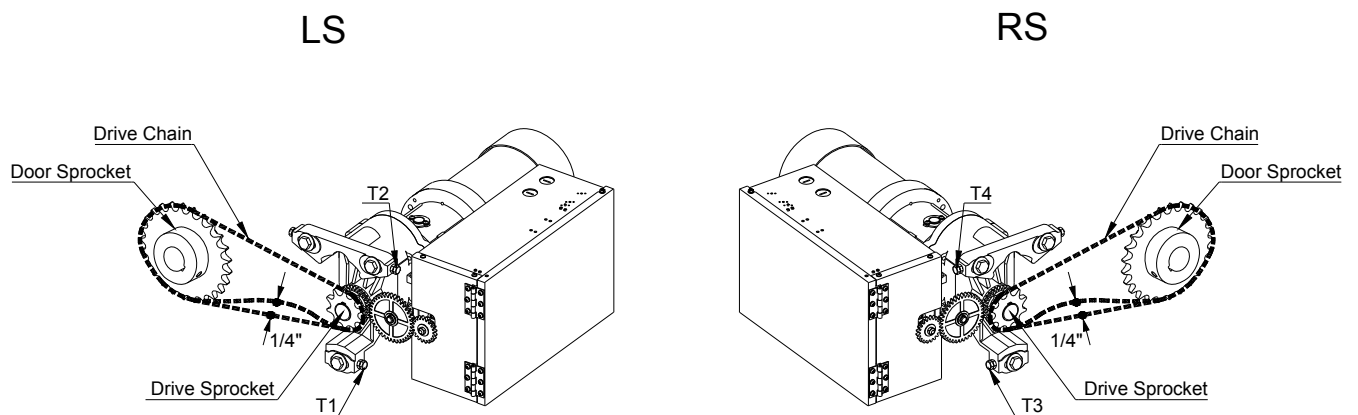

(Figure 2 for 3/4hp)

## LIMIT SWITCH ADJUSTMENT

**Make sure the limit cams are positioned between the limit switch actuators before proceeding with adjustments.**

1. Open / remove the control panel cover.
2. Open or close door to determine the moving direction of the limit switch cams.
3. Open or close door to the desired position.



**Disconnect power before adjusting limit switch cams.**

## **WARNING**

4. While pressing the spring-loaded lever (G), which holds the limit switch cams in place, adjust the limit switch cam (E or F) until the micro switch (C or D) clicking sound is heard.
5. If the limit switch cam cannot be rotated to its desired position, release the lever and move the door away from the desired position, then adjust the limit switch cam to its desired position. It may be necessary to repeat this step until the exact position has been reached.
6. Repeat step 3 and 4 for the opposite direction. Adjust close limit cams so that actuator is engaged as door fully seats at the floor.
7. Micro switch (A or B) can be adjusted to accommodate sensing edge cut-off position.

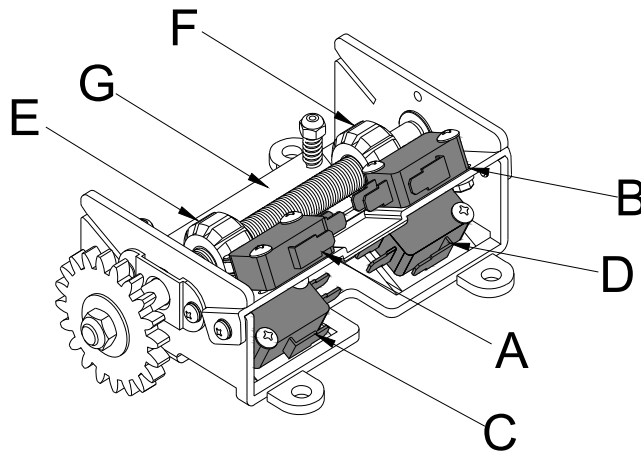

**NOTE: “C” is usually the opening side and “D” is usually the closing side.**

## WIRING INSTRUCTIONS



**Disconnect power at the fuse box before proceeding with any wiring.**

### **WARNING**

1. Do not install any wiring or attempt to run this operator without checking the wiring diagram located on the inside of the control box cover.
2. Do not turn on power until you have finished making all power and control wiring connections.
3. Do not run power and control wiring in the same conduit.
4. Any wire connected to the control panel must be protected by conduit or other means to ensure the safety and permanency of the wiring.
5. Use copper wire inside the control panel.
6. A separate fuse line of adequate capacity is needed for the operator.
7. The operator must be properly grounded. The ground screw, painted green, is located inside the control panel.



### **WARNING**

**Failure to properly ground the operator could result in electric shock and death or serious injury.**



### **WARNING**

**Unless the operator includes an internal lock sensing system, or external electrical interlocks are installed, remove or make all door locks inoperative, or secure locks in the unlocked position. Failure to disable the locks could result in damage to the door or operator.**

## CONTROL WIRING



### **WARNING**

If the door is not visible from the control station, or if any device other than the control station is used to activate the door, an entrapment protection device must be installed on the door. Failure to install an entrapment protection device may result in serious injury or death to person(s) trapped beneath the door.

1. Complete limit switch adjustments before making any sensing edge/non-contact device wiring connections to the operator.

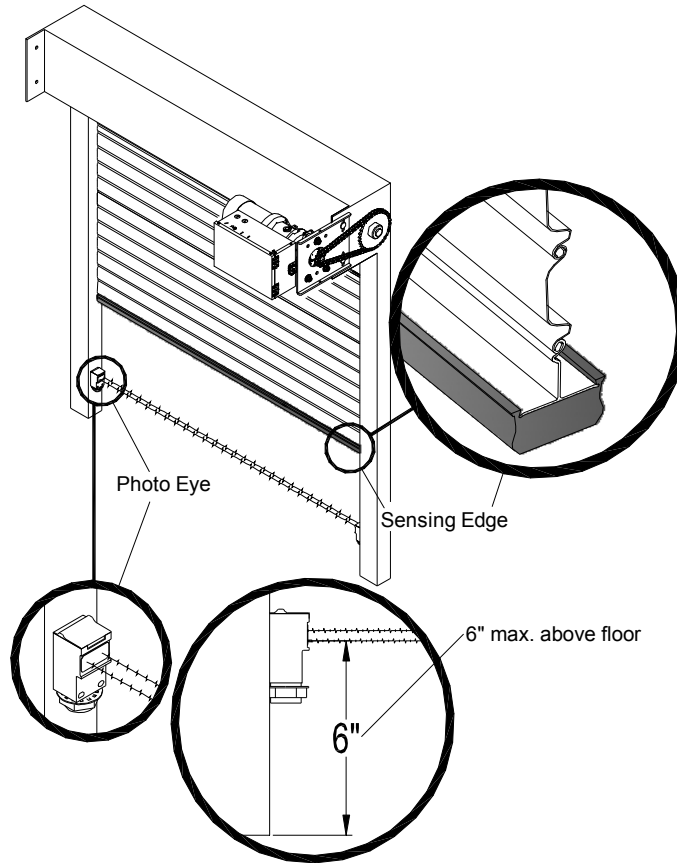

### **Entrapment Device Options:**

Sensing Module	Device Manufacturer	Model
ELR 2-wire resistive sensing edge	Miller Edge Inc. * End of Line resistor type edge must have model number with Suffix T2.	ME110*, ME111*, ME120*, ME123*, ME112*, ME113*, ME116*, ME117*
		MT21*, MU21*, MT22*, MU22*, MC22*, MC271*
		CPT223*
IR Monitored photo eye	Martec Access Products. Inc.	1266
	FRABA Inc.	Optical Edge Sensors and Photo Eyes, Models OPTOEDGE, OPTOEYE; Part Nos. OSE-T, OSE-R, OSE-P, OPE.

**Note:** Please refer to sensing device manufacturer for specific installation and maintenance requirements.



**Disconnect power at the fuse box before proceeding with any wiring.**

## **WARNING**

2. Locate the control station where the user can clearly see the operation of the door. Mount the enclosed placard adjacent or near the door.



## **WARNING**

**Controls shall be far enough from the door, or positioned such that the user is prevented from coming in contact with door while operating the controls.**

3. Do not run control wiring in the same conduit as power wiring.
4. Any wire connected to the control panel must be protected by conduit or other means to ensure the safety and permanency of the wiring.



## **WARNING**

**Do not use radio controls with your operator unless some type of entrapment protection device has been installed. Failure to do so may result in death or serious injury to person(s) trapped beneath the door.**



## **WARNING**

**Changing from left hand to right hand or vice versa could result in change of control wiring. Consult factory for details.**

5. After installation, be sure that the operator, controls, and sensing edge or other entrapment protection devices have been tested and function properly.

# FS 115V 1 PHASE (DRY CONTACT ALARM) LH (FOR FS-31E)

**EB 106-31EE L**

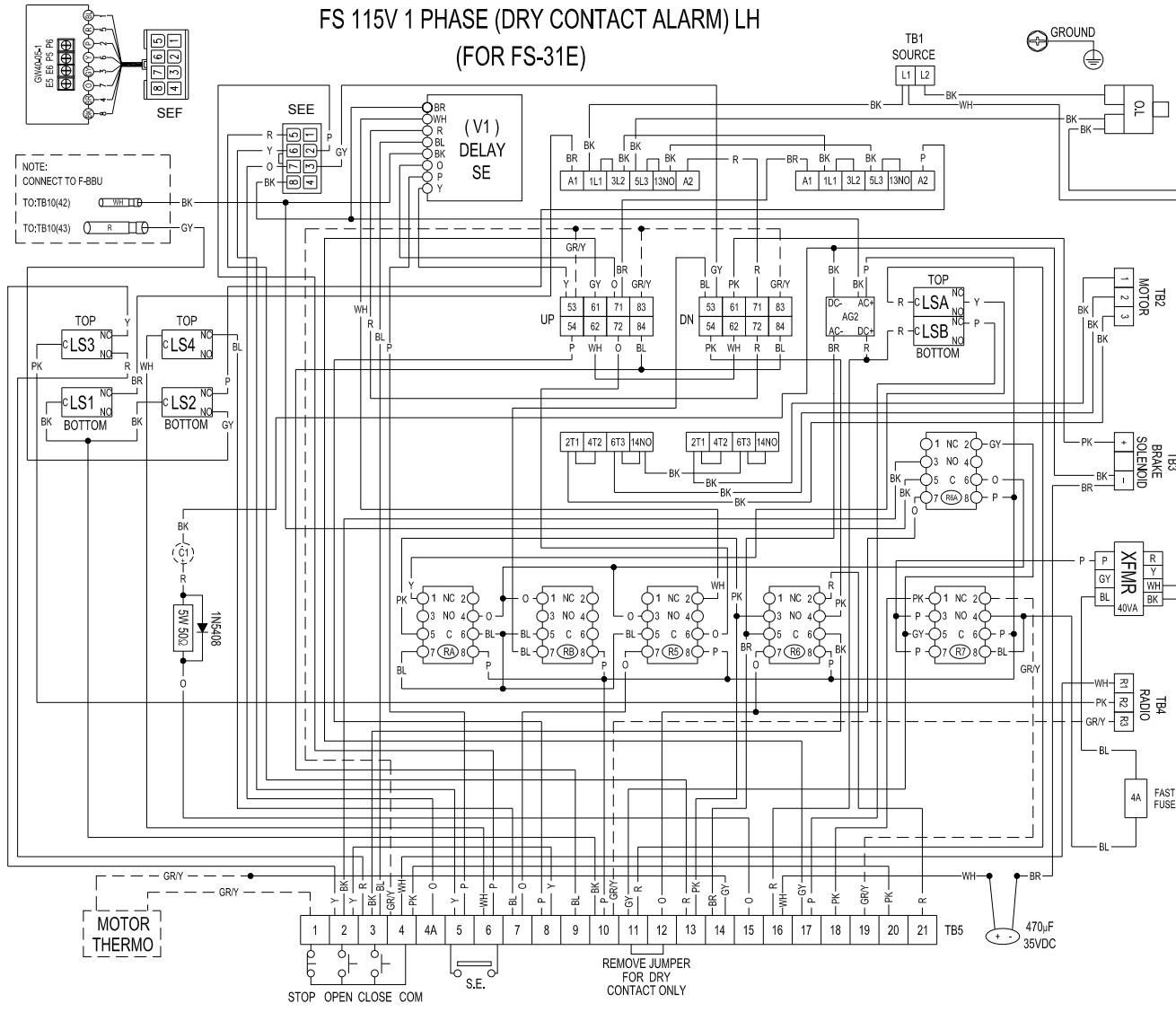

- NOTES:**
- RA-WIRELESS EDGE RELAY (COIL 24VAC)
  - RB-GRAVITY DOWN RELAY (COIL 24VAC)
  - R5-SENSING-EDGE RELAY (COIL 24VAC)
  - R6-ALARM RELAY (COIL 24VAC)
  - R6A-ALARM RELAY (COIL 24VAC)
  - R7-EXTERNAL POWER SOURCE RELAY (COIL 24VAC)
  - SEE-SENSING DEVICE CONNECT WITH ELR(E5, E6) IR(P5, P6) SENSING MODULE
  - SEF-SENSING MODULE
  - CAPACITOR 39000µF 35VDC (C1\*1)
  - LS1-OPEN MICROSWITCH
  - LS2-CLOSE MICROSWITCH
  - LS3-RADIO CONTROL MICROSWITCH
  - LS4-SENSING-EDGE MICROSWITCH
  - LSA-FUSIBLE LINK MICRO (TOP)
  - LSB-FUSIBLE LINK MICRO (BOTTOM)

- TERMINAL NUMBER:**
- 1 CONTROL STATION-STOP
  - 2 CONTROL STATION-OPEN
  - 3 CONTROL STATION-CLOSE
  - 4 CONTROL STATION-COMMON
  - 4&4A JUMP FOR MOMENTARY CONTACT CLOSE
  - 5&6 SENSING-EDGE (S.E.) CONNECTION
  - 7&8 JUMP FOR S.E. TO REVERSE
  - 9&10 DOOR MOVING WARNING SIGNAL 24VAC
  - 15&16 JUMP FOR ALARM AND POWER FAILURE 10 SEC DELAY
  - 16&17 JUMP FOR FUSIBLE LINK 10 SEC. DELAY
  - 18&19 EXTERNAL POWER INPUT 24VAC

ALARM FUNCTION	11&12	13&14	20&21
NO ALARM	JUMP	OPEN	OPEN
ALARM (GAV.DN)	DRY CONTACT	OPEN	OPEN
ALARM (PW.DN)	DRY CONTACT	JUMP	JUMP

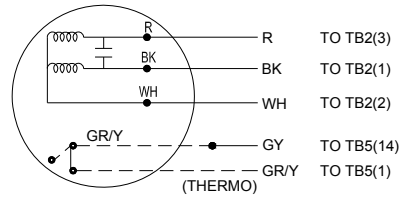

110V/115V 1 PHASE MOTOR CONNECTION  
2010.12.02

# FS 115V 1 PHASE (DRY CONTACT ALARM) RH (FOR FS-31E)

## EB 106-31EE R

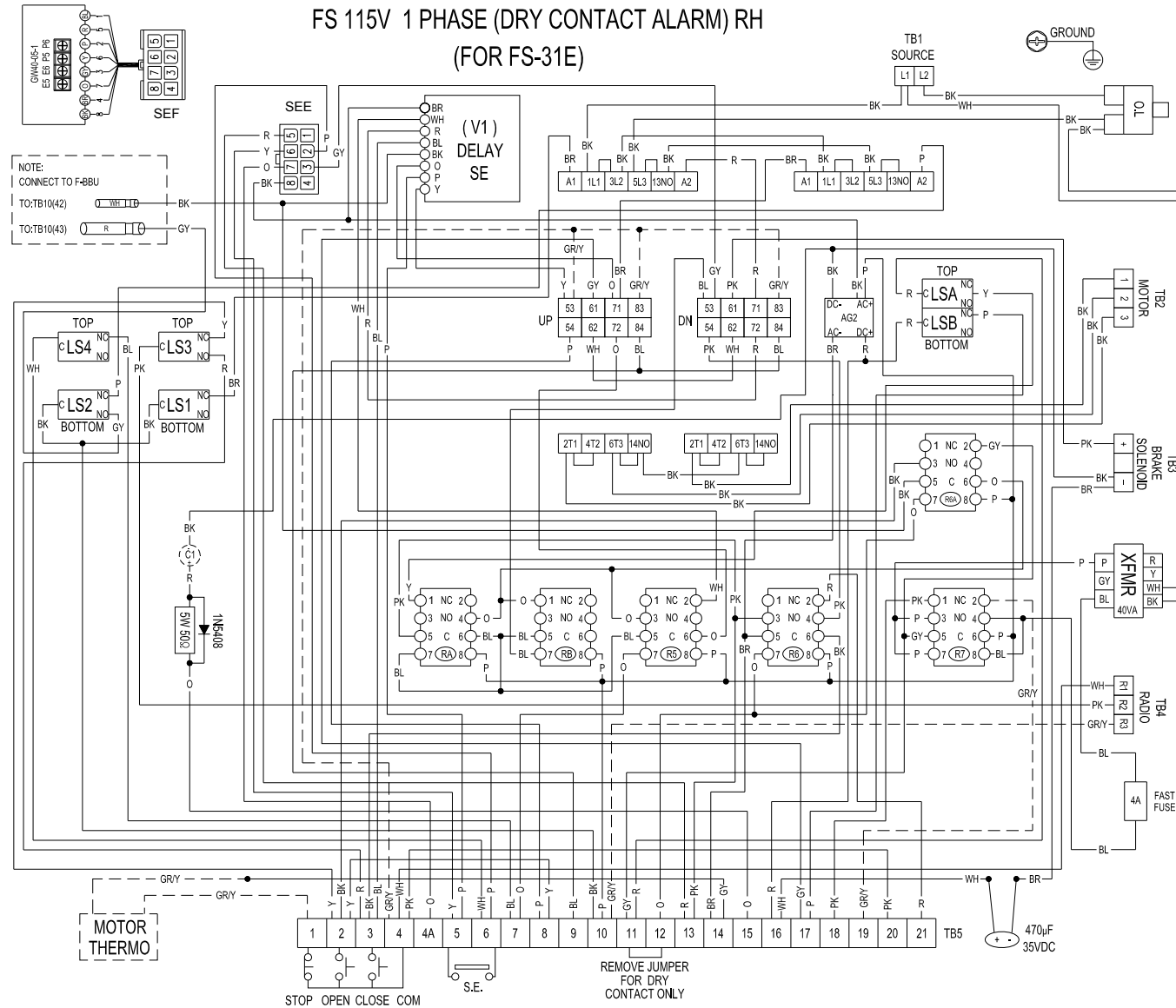

- NOTES:**
- RA-WIRELESS EDGE RELAY (COIL 24VAC)
  - RB-GRAVITY DOWN RELAY (COIL 24VAC)
  - R5-SENSING-EDGE RELAY (COIL 24VAC)
  - R6-ALARM RELAY (COIL 24VAC)
  - R6A-ALARM RELAY (COIL 24VAC)
  - R7-EXTERNAL POWER SOURCE RELAY (COIL 24VAC)
  - SEE-SENSING DEVICE CONNECT WITH ELR(E5, E6)
  - IR(P5, P6) SENSING MODULE
  - SEF-SENSING MODULE
  - CAPACITOR 3900µF 35VDC (C11)-FOR FS-31
  - LS1-OPEN MICROSWITCH
  - LS2-CLOSE MICROSWITCH
  - LS3-RADIO CONTROL MICROSWITCH
  - LS4-SENSING-EDGE MICROSWITCH
  - LSA-FUSIBLE LINK MICRO (TOP)
  - LSB-FUSIBLE LINK MICRO (BOTTOM)

- TERMINAL NUMBER:**
- 1 CONTROL STATION-STOP
  - 2 CONTROL STATION-OPEN
  - 3 CONTROL STATION-CLOSE
  - 4 CONTROL STATION-COMMON
  - 4&4A JUMP FOR MOMENTARY CONTACT CLOSE
  - 5&6 SENSING-EDGE (S.E.) CONNECTION
  - 7&8 JUMP FOR S.E. TO REVERSE
  - 9&10 DOOR MOVING WARNING SIGNAL 24VAC
  - 15&16 JUMP FOR ALARM AND POWER FAILURE 10 SEC DELAY
  - 16&17 JUMP FOR FUSIBLE LINK 10 SEC. DELAY
  - 18&19 EXTERNAL POWER INPUT 24VAC

ALARM FUNCTION	11&12	13&14	20&21
NO ALARM	JUMP	OPEN	OPEN
ALARM (GAV.DN)	DRY CONTACT	OPEN	OPEN
ALARM (PW.DN)	DRY CONTACT	JUMP	JUMP

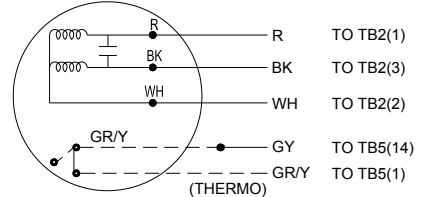

110V/115V 1 PHASE  
MOTOR CONNECTION  
2010.12.02

# FS 115V 1 PHASE (DRY CONTACT ALARM) LH (FOR FS-51E, 71E)

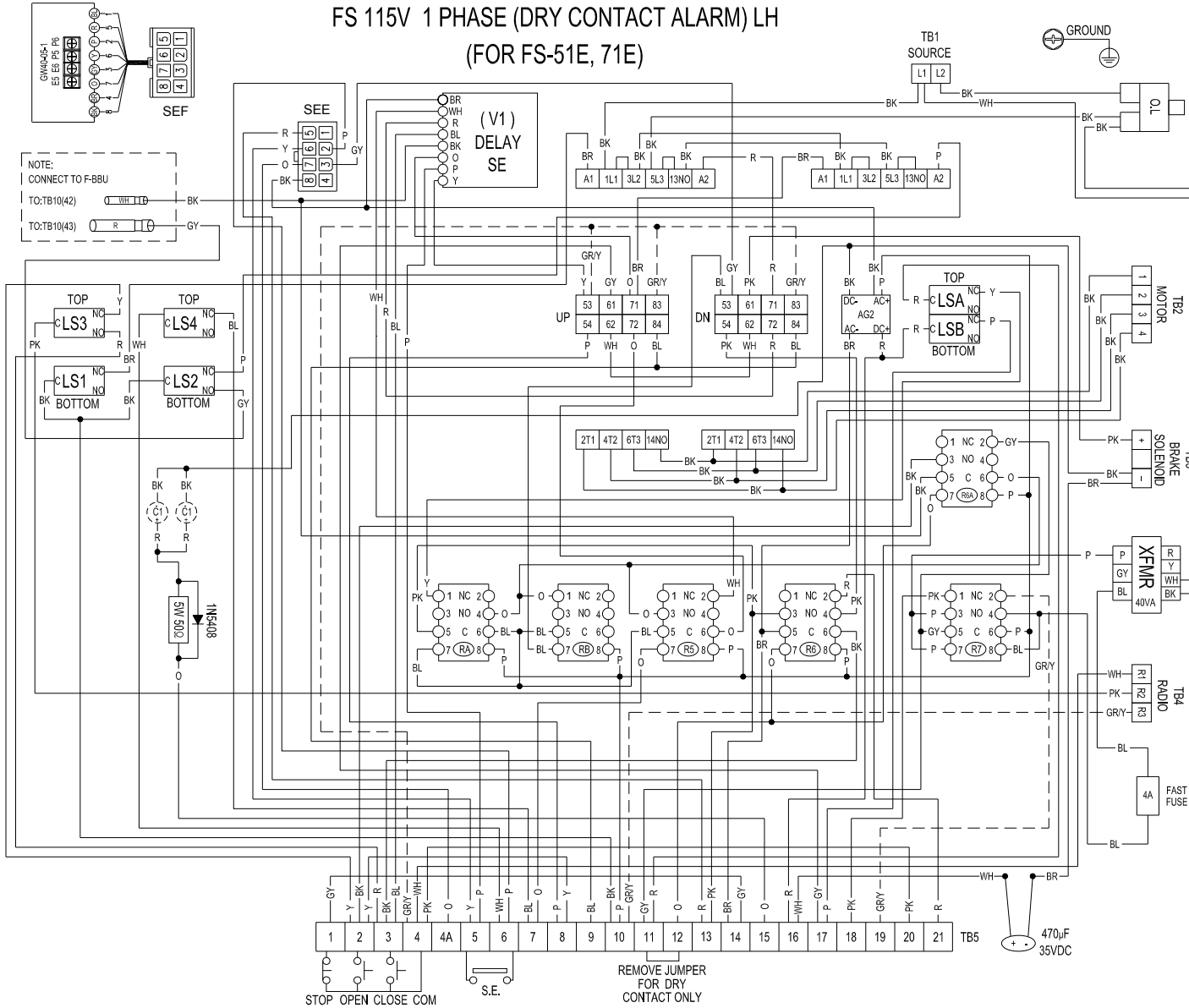

## EB 106-1EE L

- NOTES:**
- RA-WIRELESS EDGE RELAY (COIL 24VAC)
  - RB-GRAVITY RELAY (COIL 24VAC)
  - R5-SENSING-EDGE RELAY (COIL 24VAC)
  - R6-ALARM RELAY (COIL 24VAC)
  - R6A-ALARM RELAY (COIL 24VAC)
  - R7-EXTERNAL POWER SOURCE RELAY (COIL 24VAC)
  - SEE-SENSING DEVICE CONNECT WITH ELR(E5, E6)
  - IR(P5, P6) SENSING MODULE
  - SEF-SENSING MODULE
  - CAPACITOR 39000µF 35VDC (C1\*1)-FOR FS-51
  - CAPACITOR 39000µF 35VDC (C1\*2)-FOR FS-71
  - LS1-OPEN MICROSWITCH
  - LS2-CLOSE MICROSWITCH
  - LS3-RADIO CONTROL MICROSWITCH
  - LS4-SENSING-EDGE MICROSWITCH
  - LSA-FUSIBLE LINK MICRO (TOP)
  - LSB-FUSIBLE LINK MICRO (BOTTOM)

- TERMINAL NUMBER:**
- 1 CONTROL STATION-STOP
  - 2 CONTROL STATION-OPEN
  - 3 CONTROL STATION-CLOSE
  - 4 CONTROL STATION-COMMON
  - 4&4A JUMP FOR MOMENTARY CONTACT CLOSE
  - 5&6 SENSING-EDGE (S.E.) CONNECTION
  - 7&8 JUMP FOR S.E. TO REVERSE
  - 9&10 DOOR MOVING WARNING SIGNAL 24VAC
  - 15&16 JUMP FOR ALARM AND POWER FAILURE 10 SEC DELAY
  - 16&17 JUMP FOR FUSIBLE LINK 10 SEC. DELAY
  - 18&19 EXTERNAL POWER INPUT 24VAC

ALARM FUNCTION	11&12	13&14	20&21
NO ALARM	JUMP	OPEN	OPEN
ALARM (GAV.DN)	DRY CONTACT	OPEN	OPEN
ALARM (PW.DN)	DRY CONTACT	JUMP	JUMP

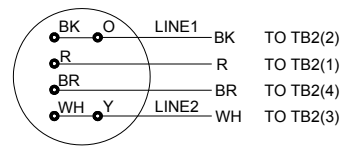

110V/115V 1 PHASE  
MOTOR CONNECTION

2010.12.02

# FS 115V 1 PHASE (DRY CONTACT ALARM) RH (FOR FS-51E, 71E)

**EB 106-1EE R**

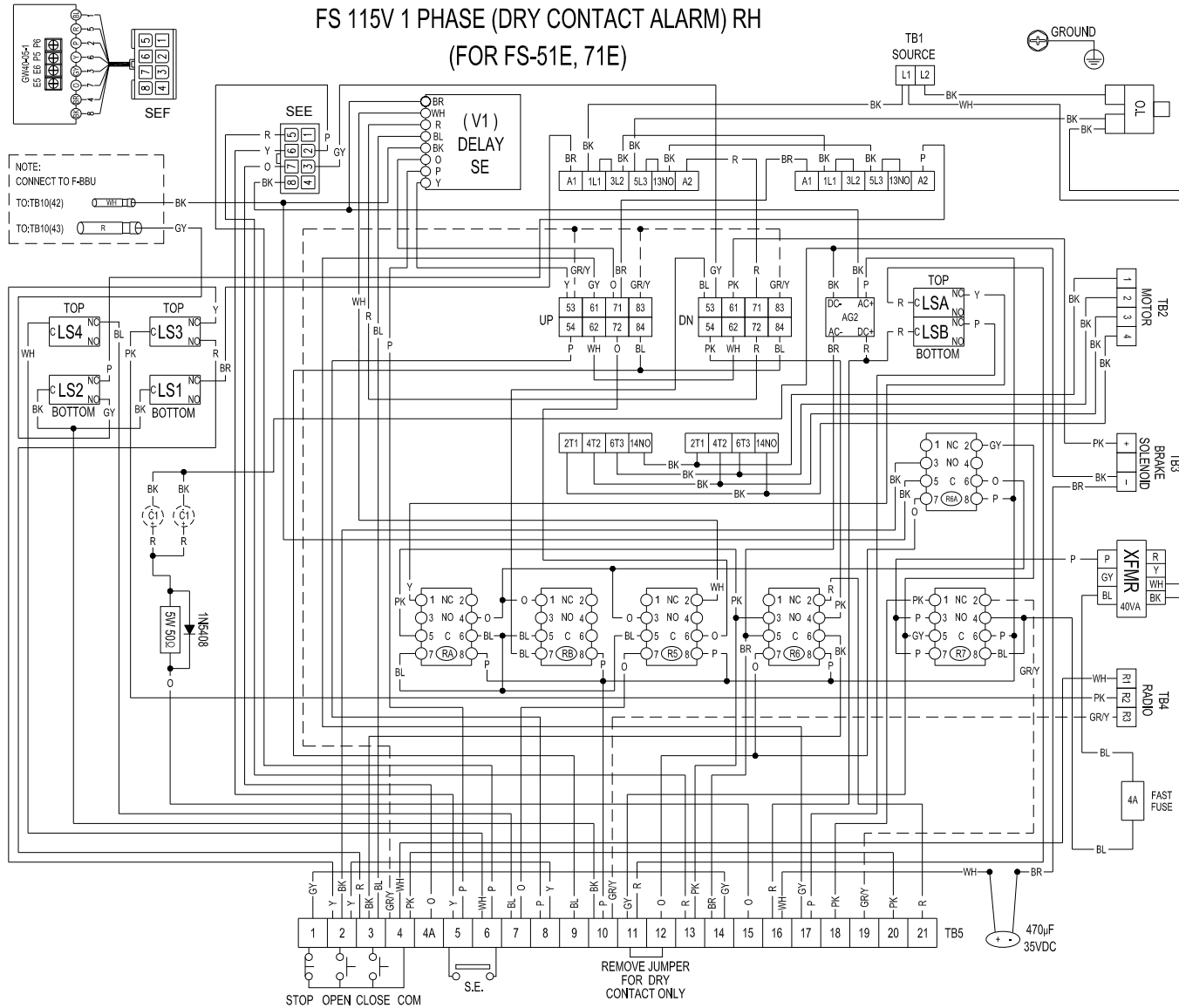

- NOTES:**
- RA-WIRELESS EDGE RELAY (COIL 24VAC)
  - RB-GRAVITY DOWN RELAY (COIL 24VAC)
  - R5-SENSING-EDGE RELAY (COIL 24VAC)
  - R6-ALARM RELAY (COIL 24VAC)
  - R6A-ALARM RELAY (COIL 24VAC)
  - R7-EXTERNAL POWER SOURCE RELAY (COIL 24VAC)
  - SEE-SENSING DEVICE CONNECT WITH ELR(E5, E6) (R(P5, P6) SENSING MODULE)
  - SEF-SENSING MODULE
  - CAPACITOR 39000µF 35VDC (C1\*1)-FOR FS-51
  - CAPACITOR 39000µF 35VDC (C1\*2)-FOR FS-71
  - LS1-OPEN MICROSWITCH
  - LS2-CLOSE MICROSWITCH
  - LS3-RADIO CONTROL MICROSWITCH
  - LS4-SENSING-EDGE MICROSWITCH
  - LSA-FUSIBLE LINK MICRO (TOP)
  - LSB-FUSIBLE LINK MICRO (BOTTOM)

- TERMINAL NUMBER:**
- 1 CONTROL STATION-STOP
  - 2 CONTROL STATION-OPEN
  - 3 CONTROL STATION-CLOSE
  - 4 CONTROL STATION-COMMON
  - 4&4A JUMP FOR MOMENTARY CONTACT CLOSE
  - 5&6 SENSING-EDGE (S.E.) CONNECTION
  - 7&8 JUMP FOR S.E. TO REVERSE
  - 9&10 DOOR MOVING WARNING SIGNAL 24VAC
  - 15&16 JUMP FOR ALARM AND POWER FAILURE 10 SEC DELAY
  - 16&17 JUMP FOR FUSIBLE LINK 10 SEC. DELAY
  - 18&19 EXTERNAL POWER INPUT 24VAC

ALARM FUNCTION	11&12	13&14	20&21
NO ALARM	JUMP	OPEN	OPEN
ALARM (GAV.DN)	DRY CONTACT	OPEN	OPEN
ALARM (PW.DN)	DRY CONTACT	JUMP	JUMP

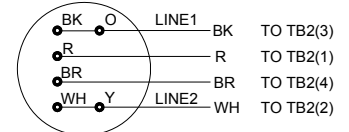

110V/115V 1 PHASE  
MOTOR CONNECTION  
2010.12.02

# FS 230V 1 PHASE (DRY CONTACT ALARM) LH (FOR FS-32E, 52E, 72E)

**EB 206EE L**

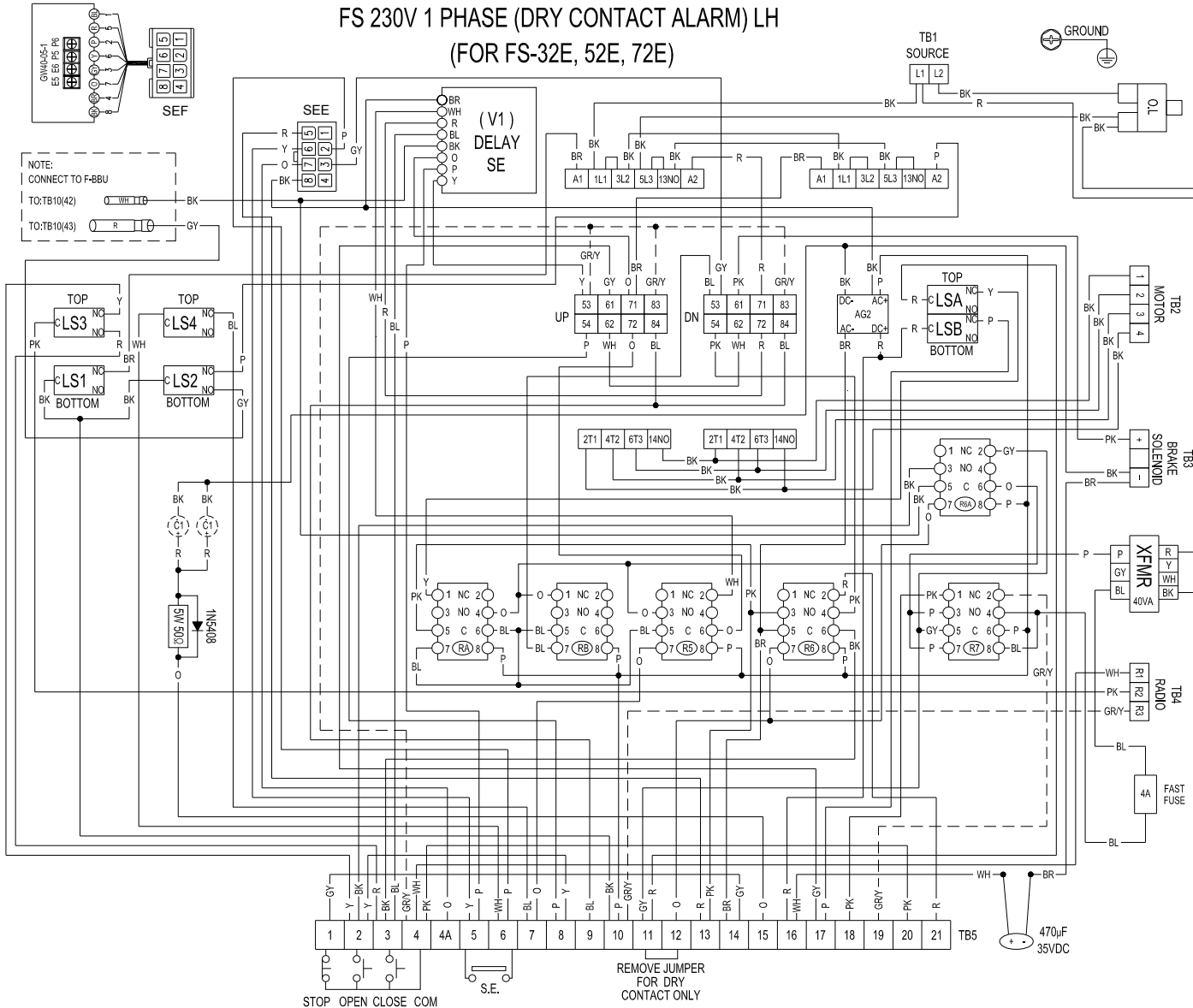

- NOTES:**
- RA-WIRELESS EDGE RELAY (COIL 24VAC)
  - RB-GRAVITY RELAY (COIL 24VAC)
  - R5-SENSING-EDGE RELAY (COIL 24VAC)
  - R6-ALARM RELAY (COIL 24VAC)
  - R6A-ALARM RELAY (COIL 24VAC)
  - R7-EXTERNAL POWER SOURCE RELAY (COIL 24VAC)
  - SEE-SENSING DEVICE CONNECT WITH ELR(E5, E6) IR(P5, P6) SENSING MODULE
  - SEF-SENSING MODULE
  - CAPACITOR 39000µF 35VDC (C1'1)-FOR FS-32, FS-52
  - CAPACITOR 39000µF 35VDC (C1'2)-FOR FS-72
  - LS1-OPEN MICROSWITCH
  - LS2-CLOSE MICROSWITCH
  - LS3-RADIO CONTROL MICROSWITCH
  - LS4-SENSING-EDGE MICROSWITCH
  - LSA-FUSIBLE LINK MICRO (TOP)
  - LSB-FUSIBLE LINK MICRO (BOTTOM)
- TERMINAL NUMBER:**
- 1 CONTROL STATION-STOP
  - 2 CONTROL STATION-OPEN
  - 3 CONTROL STATION-CLOSE
  - 4 CONTROL STATION-COMMON
  - 4&4A JUMP FOR MOMENTARY CONTACT CLOSE
  - 5&6 SENSING-EDGE (S.E.) CONNECTION
  - 7&8 JUMP FOR S.E. TO REVERSE
  - 9&10 DOOR MOVING WARNING SIGNAL 24VAC
  - 15&16 JUMP FOR ALARM AND POWER FAILURE 10 SEC DELAY
  - 16&17 JUMP FOR FUSIBLE LINK 10 SEC DELAY
  - 18&19 EXTERNAL POWER INPUT 24VAC

ALARM FUNCTION	11&12	13&14	20&21
NO ALARM	JUMP	OPEN	OPEN
ALARM (GAV.DN)	DRY CONTACT	OPEN	OPEN
ALARM (PW.DN)	DRY CONTACT	JUMP	JUMP

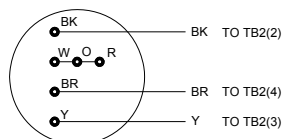

**230V 1 PHASE  
MOTOR CONNECTION**

2010.12.02

# FS 230V 1 PHASE (DRY CONTACT ALARM) RH (FOR FS-32E, 52E, 72E)

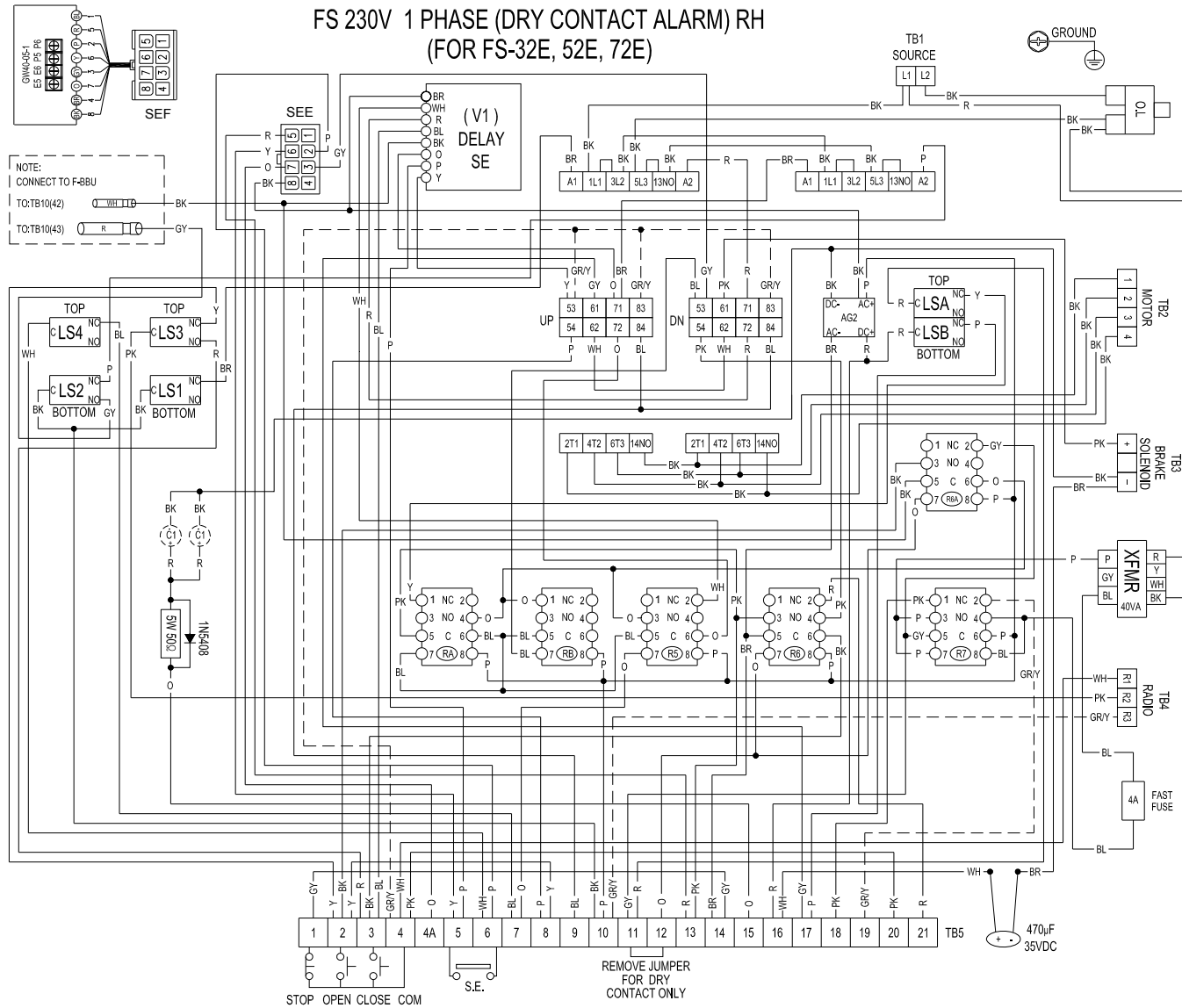

## EB 306EE R

- NOTES:**
- RA-WIRELESS EDGE RELAY (COIL 24VAC)
  - RB-GRAVITY DOWN RELAY (COIL 24VAC)
  - R5-SENSING-EDGE RELAY (COIL 24VAC)
  - R6-ALARM RELAY (COIL 24VAC)
  - R6A-ALARM RELAY (COIL 24VAC)
  - R7-EXTERNAL POWER SOURCE RELAY (COIL 24VAC)
  - SEE-SENSING DEVICE CONNECT WITH ELR(E5, E6) IR(P5, P6) SENSING MODULE
  - SEF-SENSING MODULE
  - CAPACITOR 39000µF 35VDC (C1\*1)-FOR FS-32, FS-52
  - CAPACITOR 39000µF 35VDC (C1\*2)-FOR FS-72
  - LS1-OPEN MICROSWITCH
  - LS2-CLOSE MICROSWITCH
  - LS3-RADIO CONTROL MICROSWITCH
  - LS4-SENSING-EDGE MICROSWITCH
  - LSA-FUSIBLE LINK MICRO (TOP)
  - LSB-FUSIBLE LINK MICRO (BOTTOM)
- TERMINAL NUMBER:**
- 1 CONTROL STATION-STOP
  - 2 CONTROL STATION-OPEN
  - 3 CONTROL STATION-CLOSE
  - 4 CONTROL STATION-COMMON
  - 4&4A JUMP FOR MOMENTARY CONTACT CLOSE
  - 5&8 SENSING-EDGE (S.E.) CONNECTION
  - 7&8 JUMP FOR S.E. TO REVERSE
  - 9&10 DOOR MOVING WARNING SIGNAL 24VAC
  - 15&16 JUMP FOR ALARM AND POWER FAILURE 10 SEC DELAY
  - 16&17 JUMP FOR FUSIBLE LINK 10 SEC DELAY
  - 18&19 EXTERNAL POWER INPUT 24VAC

ALARM FUNCTION	11&12	13&14	20&21
NO ALARM	JUMP	OPEN	OPEN
ALARM (GAV.DN)	DRY CONTACT	OPEN	OPEN
ALARM (PW.DN)	DRY CONTACT	JUMP	JUMP

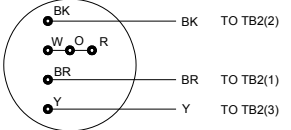

230V 1 Phase  
MOTOR CONNECTION

2010.12.02

FS 208/230V 3 PHASE (DRY CONTACT ALARM) LH  
(FOR FS-33E, 53E, 73E)

EB 406EE L

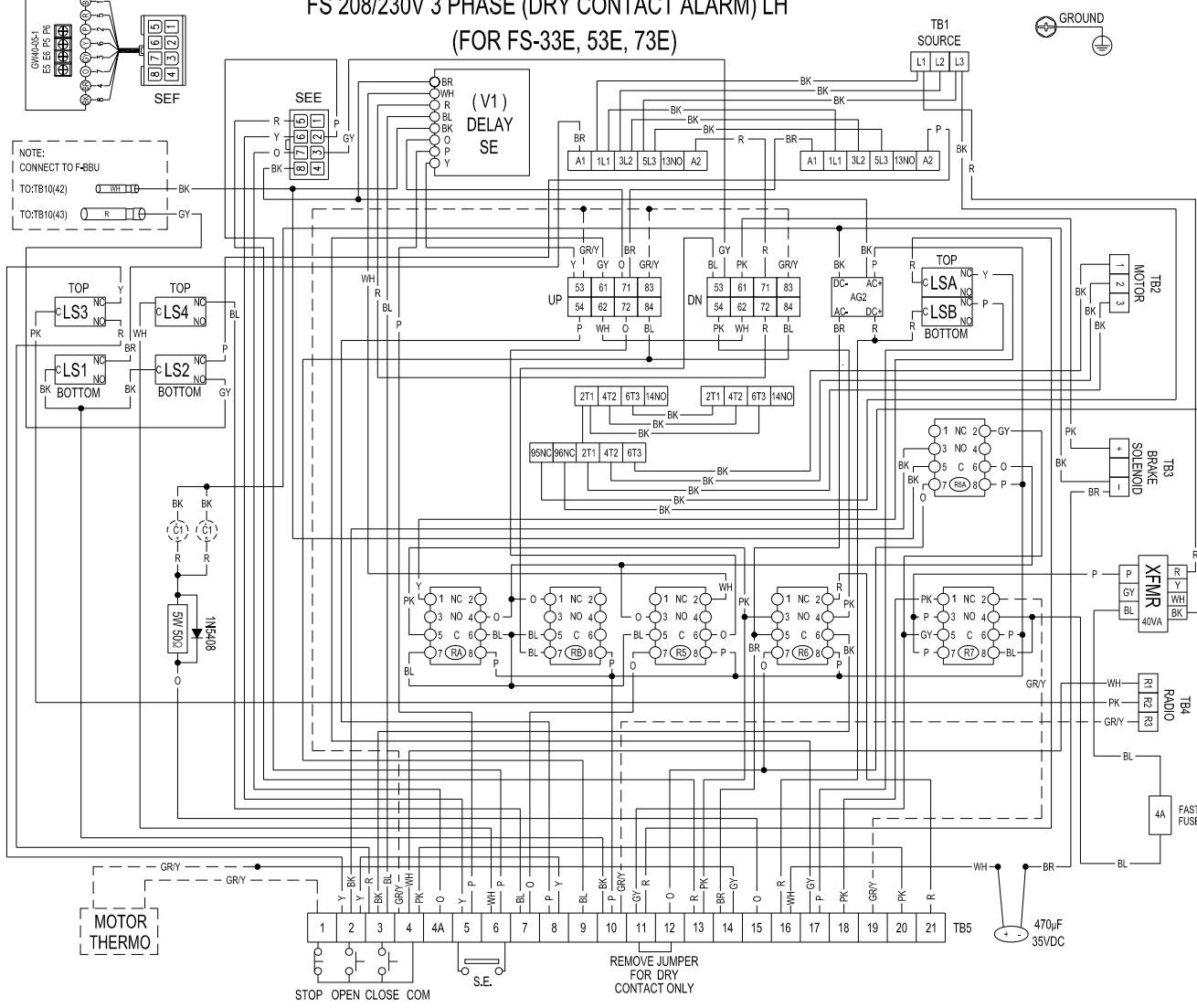

- NOTES:
- RA-WIRELESS EDGE RELAY (COIL 24VAC)
  - RB-GRAVITY DOWN RELAY (COIL 24VAC)
  - R5-SENSING-EDGE RELAY (COIL 24VAC)
  - R6-ALARM RELAY (COIL 24VAC)
  - R6A-ALARM RELAY (COIL 24VAC)
  - R7-EXTERNAL POWER SOURCE RELAY (COIL 24VAC)
  - SEE-SENSING DEVICE CONNECT WITH ELR(E5, E6)
  - IR(P5, P6) SENSING MODULE
  - SEF-SENSING MODULE
  - CAPACITOR 39000µF 35VDC (C1\*1)-FOR FS-33 FS-53
  - CAPACITOR 39000µF 35VDC (C1\*2)-FOR FS-73
  - LS1-OPEN MICROSWITCH
  - LS2-CLOSE MICROSWITCH
  - LS3-RADIO CONTROL MICROSWITCH
  - LS4-SENSING-EDGE MICROSWITCH
  - LSA-FUSIBLE LINK MICRO (TOP)
  - LSB-FUSIBLE LINK MICRO (BOTTOM)
- TERMINAL NUMBER:
- 1 CONTROL STATION-STOP
  - 2 CONTROL STATION-OPEN
  - 3 CONTROL STATION-CLOSE
  - 4 CONTROL STATION-COMMON
  - 4&4A JUMP FOR MOMENTARY CONTACT CLOSE
  - 5&6 SENSING-EDGE (S.E.) CONNECTION
  - 7&8 JUMP FOR S.E. TO REVERSE
  - 9&10 DOOR MOVING WARNING SIGNAL 24VAC
  - 15&16 JUMP FOR ALARM AND POWER FAILURE 10 SEC DELAY
  - 16&17 JUMP FOR FUSIBLE LINK 10 SEC DELAY
  - 18&19 EXTERNAL POWER INPUT 24VAC

ALARM FUNCTION	11&12	13&14	20&21
NO ALARM	JUMP	OPEN	OPEN
ALARM (GAV.DN)	DRY CONTACT	OPEN	OPEN
ALARM (PW.DN)	DRY CONTACT	JUMP	JUMP

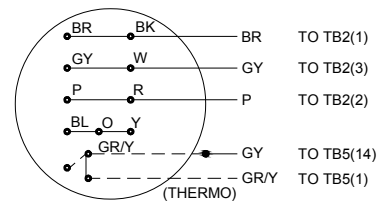

208V/230V 3 PHASE  
MOTOR CONNECTION 2010.12.02



















