

**COOKSON** Preferred door solutions.®

**CONTROLGARD™  
BRAKING CHAIN HOIST  
RETROFIT INSTRUCTIONS**

## RETROFIT HAND CHAIN

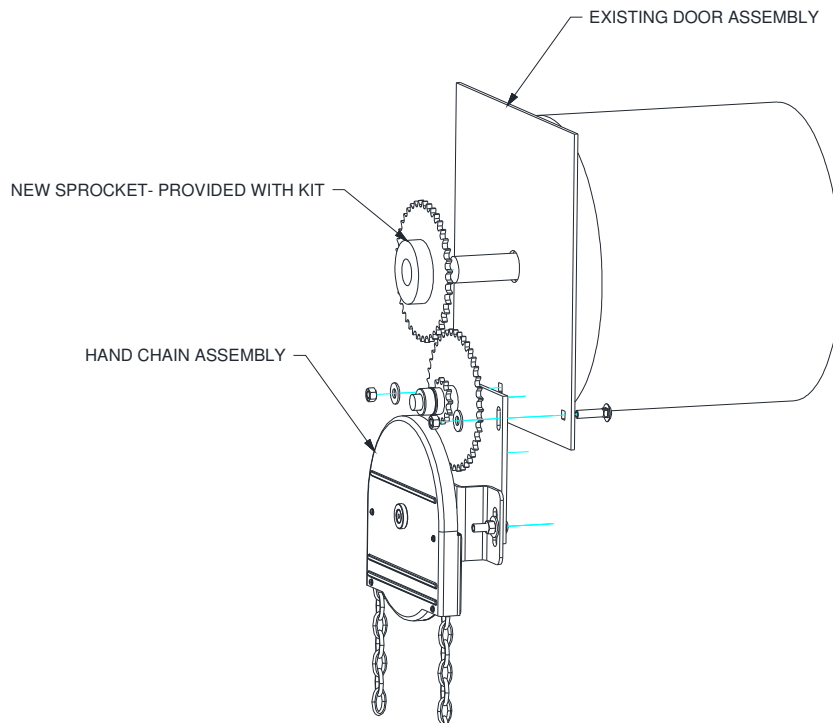

1. Remove retrofit hand chain kit from packaging. Check driven sprocket bore matches door shaft diameter.
2. With door in the closed position remove current hand chain operator and driven sprocket from the door.
3. Place new driven sprocket on door shaft. Do not secure in place as sprocket alignment will need to be done later.
4. Bolt new chain operator to bracket using provided 3/8-16 carriage bolts.
5. Align driven sprocket on shaft with drive sprocket of chain operator.
6. Secure driven sprocket in place.
7. Replace drive chain.
8. Operate door to ensure proper installation.