

Installation Instructions, SentryGate 4

Section 1 – Table of Contents





Section 2 – Safety Check List	2
Section 3 – Freight Receiving	3
Section 4 – Pre-installation	4
Section 5 – Torque Specifications	5
Section 6 – Maintenance Schedule	6

Section 2 – Safety Check List

Rolling doors are large, movable objects. They move with the help of electric motors or manual operators (chain, crank, push up, etc), and most have springs under high tension. These items and their components can cause injury. In order to avoid injury to yourself and others, please follow the instructions in this manual.

- **Review the potential hazards and preventative measures listed below:**

Table 2.1 - Potential Hazards and Preventative Measures

Potential Hazard	Preventative Measure	
	<p style="text-align: center;">⚠ DANGER</p> <p style="text-align: center;">Pinned or crushed by closing door.</p>	<ul style="list-style-type: none"> • Keep yourself and others clear of opening while door is in motion. • Do not allow children to play near or operate door. • Do not operate if door becomes jammed or broken.
	<p style="text-align: center;">⚠ WARNING</p> <p style="text-align: center;">Struck by adjusting wheel bar while applying spring turns.</p>	<ul style="list-style-type: none"> • Be sure bar is adequate in strength and long enough to allow installer to apply the necessary torque. • Make sure bar is fully seated into the adjusting wheel slot before applying pressure. • Use two bars while applying turns to the adjusting wheel.
	<p style="text-align: center;">⚠ WARNING</p> <p style="text-align: center;">Electrical shock.</p>	<ul style="list-style-type: none"> • Make sure electrical operator is properly grounded. • Turn off source power completely prior to servicing the motor. • Make sure wires are clear of any moving or potentially moving parts. • Avoid pinching wires when installing the motor cover.
	<p style="text-align: center;">⚠ WARNING</p> <p style="text-align: center;">Pinched by moving components.</p>	<ul style="list-style-type: none"> • Make sure the motor is turned off and unplugged before working with moving parts such as roller chain and sprockets, drop-out mechanisms, adjusting wheels, etc. • Locate the possible pinch-points of the unit (Drive chain, coil area, bottom bar, etc.) Do not operate the door while someone is near these areas.

- **Check the following during installation and before leaving the job site:**
 - a. If the unit has tension springs, be sure the proper amount of tension is applied to the torsion springs, in order to properly counterbalance the weight of the curtain.
 - b. Securely fasten the tension adjusting wheel in place with the appropriate hardware provided.
 - c. Check that the keys and/or cotter pins have been set in place and fit properly at all sprockets or gears.
 - d. Check that the setscrews in each sprocket or gear (one over the key and one offset from the key) have been tightened properly.
 - e. Check all fasteners holding the unit to the building structures.
 - f. Check all fasteners used to assemble the components of the unit together.
 - g. Instruct owner or representative in the proper method of operating the door.

Section 3 – Freight Receiving

- **Upon delivery, check condition of components for damage.**
- **If damage occurred in transit, the installation should not proceed without authorization.**

NOTICE

If the installation proceeds, neither the carrier nor the manufacturer will assume responsibility for replacing the damaged material.

- **If the installation is stopped due to damage, do the following:**
 1. Take pictures of the damage.
 2. Do not move material from point of delivery to other premises once the damaged components are discovered.
 3. Do not unpack, if the damage is visible prior to removing packaging, until an inspection is made.
 4. If the damage is found while removing contents from packaging, the packaging material must be saved until inspection is made.
 5. Container and packaging should be retained by consignee until inspection is made.
 6. Have components inspected by carrier's representative within 15 days from date of delivery.
 7. Consignee must obtain a copy of the Inspection Report.
- **Returning damaged components:**
 1. Obtain permission from carrier to return.
 2. Route the return shipment via the identical carrier(s) involved in the original shipment.
 3. Notify the manufacturer when shipment is returned to manufacture plant.
- **Verify that all components have arrived. Look for the following:**
 1. Job construction drawings featuring different views (elevation, section, plan, etc.)
 2. (2) Guide assemblies; check for guide weathering if included in order
 3. Barrel assembly
 4. Curtain assembly with bottom bar attached
 5. (2) Bracket assemblies
 6. Operator; if not attached to bracket
 7. Operator cover; may not be included in order
 8. Adjusting wheel; if the barrel assembly contains springs
 9. Inertia brake; typically on units with springless barrel assemblies
 10. Hood and hood supports; may not be included in order
 11. Hardware
 12. Misc. items (Reelite, lintel seal, hood baffle, etc.)
 13. Verify material/finish/color of components matches what is listed on the job construction drawings and/or what was ordered.
- **If the delivery is incomplete:**
 1. Make note on delivery receipt.
 2. Note should be verified by driver's signature.
 3. Notify carrier and manufacturer.

Section 4 - Pre-installation

- **Read entire instruction manual thoroughly. The manufacturer will not be held responsible for any charges incurred due to improperly installed components.**
 - a. Only trained door systems technicians should perform installation, maintenance, etc.
 - b. Each unit comes with an individual item number. If the job contains multiple units, be sure to locate all the components for each item and separate each.

⚠WARNING

Do not interchange parts from one door to another.

- c. Find the job construction drawings for the unit being installed and check the dimensions of the opening against those on the drawings. See **Figure 4.1** below.
- d. If the opening dimensions differ from those on the drawings, **do not proceed**, check with distributor/manufacturer to be sure the correct door is being installed.
- e. Check the jambs of the opening for plumb. Check the head/lintel and floor for level. If the unit is to be free standing, for example mounted to tubes, check the floor and ceiling for level and for adequate mounting areas at the top and bottom.
- f. If your guides are embedded please contact the Service Department at 1-800-233-8366 for additional warning labels to be applied to finished wall. Ask for "Safety Instruction Labels."

Note: *The floor may not be level if a pitched bottom bar is specified.*

- **Work Area:**
 - a. The key to a smooth installation is a clean and well-prepared work environment. Once the components have been inspected and the job construction drawings have been reviewed; lay out the components in the order of installation.
 - b. The opening for the door should be cleaned and inspected for rough surfaces and construction debris.
 - c. Lastly the mounting hardware supplied with the door should correspond with the surface and construction features of the opening.
 - d. The basic assembly sequence is as follows: guides, barrel w/ rings or tapped holes, brackets, motor operator (if applicable), curtain, bellmouth, stoppers, weather stripping, hood, and operator/adjustor/idler covers.

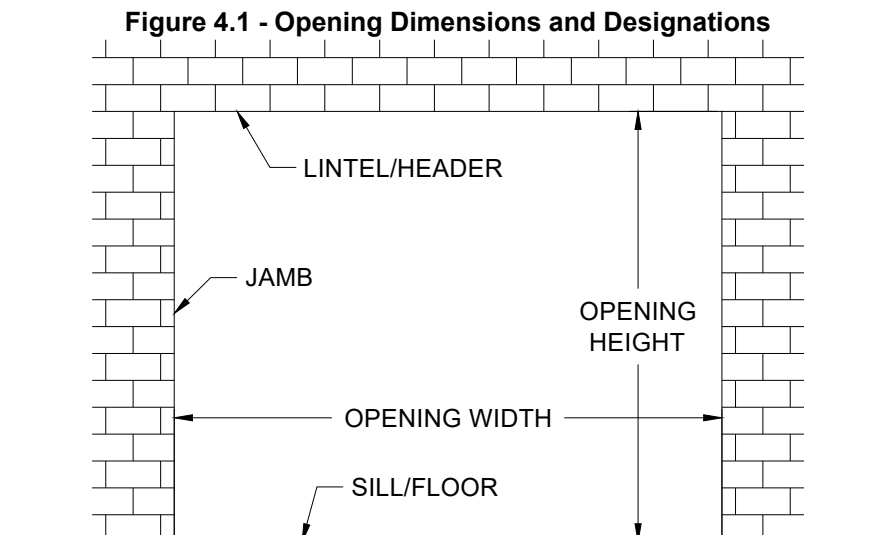

Section 5 – Torque Specifications

Table 5.1 – Torque Recommendations for Guide Assembly and Wall Fasteners

Bolt size/type	Torque (ft lbs) ^a
1/4-20 Grade 2 steel bolt	6
5/16-18 Black Oxide Socket Cap	25
3/8-16 18-8 stainless steel bolt	20
3/8-16 Grade 2 steel bolt	20
3/8-16 Grade 5 steel bolt	31
3/8-16 Grade 8 steel bolt	45
1/2-13 Grade 5 steel bolt	75
1/2-13 Grade 8 steel bolt	107
5/8-11 Grade 8 steel bolt	212
3/4-10 Grade 8 steel bolt	376
^a The recommended torque for steel bolts is based on a plated bolt that has not been lubricated.	

Table 5.2 - Torque Recommendations for Solid Masonry Wall Anchors

Anchor Size (nominal)	Manufacturer/Torque (ft lbs) ^a	
	Simpson Wedge-All	Hilti-Kwik Bolt 3
3/8	30	20
1/2	60	40
5/8	90	85
3/4	150	150
^a Torque values for grout filled block are different, reference bolt manufacturer for these values.		

Section 6 – Installation Instructions

▪ **Maintenance Schedule:**

Note: If any of the following problems exist, **do not** operate the door until repaired.

Component	What to look for and how often the components must be inspected:	Weekly	Monthly	Quarterly	What to do if problem exists:
Curtain & Bottom Bar	Are any curtain components damaged (slats, endlocks, etc.)?	X			Contact Service about replacing damaged parts.
	Is bottom bar damaged?	X			Contact Service about replacing damaged parts.
	Are bottom bar fasteners in place and properly tightened?		X		Fasteners must be inspected/replaced and properly tightened.
	Are fasteners attaching curtain to the barrel in place and properly tightened?		X		Fasteners must be inspected/replaced and properly tightened.
	Do you notice any hang-ups, jamming or other problems preventing the door from moving smoothly throughout the opening?	X			Check for external issues, if none exist, contact Service.
	Do you notice any odd or excessive noise when the door is operated?	X			Check for external issues, if none exist, contact Service.
	If there is a bottom seal, is it damaged?		X		Contact Service about replacing damaged parts.
	If there is locking, does it function properly?	X			Check for external issues, if none exist, contact Service.
Brackets	Are brackets plumb and perpendicular with wall?			X	Contact Service.
	Are bracket fasteners in place and properly tightened?			X	Fasteners must be inspected/replaced and properly tightened.
	Do you notice signs of excessive wear on the bearings (i.e. binding, excessive noise, etc.)?		X		If there is a grease fitting, apply grease, if not, contact Service.
	Is adjusting wheel & pin secure?			X	Contact Service.
	Is drive chain sufficiently lubricated?			X	Apply chain lube.
	Is drive chain in need of tightening?			X	Contact Service for instructions on how to tension the chain.
	Is drive or driven sprocket damaged?		X		Contact Service about replacing damaged parts.
Guides	Are wall fasteners in place and properly tightened?		X		Fasteners must be inspected/replaced and properly tightened.
	Are guide assembly fasteners in place and properly tightened?		X		Fasteners must be inspected/replaced and properly tightened.
	Is guide gap dimension correct?		X		Check job construction drawings and adjust gap as required. If job construction drawings are not available, contact Service.
	Are any of the guide parts bent or damaged?		X		Contact Service.
	Are stoppers loose, damaged, or missing?		X		Stoppers must be inspected/replaced and properly tightened.
Hood and Fascia	Is hood/fascia dented or damaged?			X	Remove hood/fascia. Repair if possible. If not leave hood/fascia off and contact Service.
	Is curtain rubbing against the hood/fascia?	X			Hood/fascia may have been damaged. Contact Service.
	Is hood/fascia level?			X	Check fasteners, they may be loose or missing. Replace as soon as possible.

Section 6 – Installation Instructions

	Are guide assembly fasteners in place and properly tightened?		X		Fasteners must be inspected/replaced and properly tightened.
	Is hood support level?			X	Check fasteners, they may be loose or missing. Replace as soon as possible.
Door operation	Does the door require excessive force to open?		X		Check for hang-ups or obstructions. Ensure spring tension is set correctly. Contact Service.
	If the door contains locking, does the locking mechanism function properly and securely hold the door in the closed position?		X		Check for damage and other external issues. Contact Service.
	If there is a sensing edge, does it function properly?	X			Cut power and check for loose wires. Contact Service for further instruction.
Motor Operator	Are the fasteners attaching the motor-to-the mounting bracket, and mounting bracket-to-the door bracket secure?			X	Fasteners must be inspected/replaced and properly tightened. Contact Service for replacement hardware.
	Are the sprockets properly aligned?			X	Realign the sprockets as secure using the set screws. Recheck chain tension.
	Are the sprocket keys properly aligned with sprockets and securely fastened with the set screws?			X	Reposition the keys so they fully engage the keyway in the sprocket. Tighten the set screws.
	Is the door stopping correctly at the open (before bottom bar contacts the stoppers) and closed (as soon as the bottom bar contacts the floor) positions?		X		Limits may have to be adjusted in the motor operator. Refer to the operator owner's manual or contact Service.
	Is the operator functioning normally?		X		Refer to the <i>Operator Troubleshooting Table</i> on the following page to diagnose the problem.

Section 6 – Installation Instructions

▪ **Operator Troubleshooting:**

Note: *If you suspect you are having an issue with your operator, use the following table to determine the potential causes. If the provided solution does not eliminate the issue, or the table does not address your particular problem, contact the Service Department.*

Component	Problem	Potential Cause	Solution
Motor Operator	Motor Operator does not run when OPEN or CLOSE button is pushed	The circuit breaker may be flipped or fuse blown.	Reset breaker or replace fuse. Contact Service if replacement fuse is needed.
		The thermal overload may be tripped.	Reset thermal overload.
		Manual interlock switch is open (on units with emergency operator).	Close manual interlocks.
		External interlock may be opened.	Close external interlock.
	Motor operator runs but the door does not move	Sprocket key may be missing or drive chain may be broken.	Contact Service for repair parts. Install key or replace chain.
		Clutch may be slipping.	Adjust if possible. Contact Service otherwise.
	Motor hums but does not run	Door or drive chain may be jamming.	Check for hang-ups or obstructions. Try to operate manually. If issue persists, contact Service.
		Dead phase in 3 phase system.	Check power supply.
		Brake does not release.	Check power to brake solenoid.
		Open motor winding.	Check that all connections are secure.
	Motor operator runs in wrong direction and limits do not function	3 phase operator power supply is out of phase.	Interchange any 2 power leads to unit.
	Door drifts when motor shuts off	Brake may be improperly adjusted or broken.	Check brake components. Contact Service for replacement parts or adjust instructions.
	Motor operator does not shut off at full OPEN or at full CLOSE position	Limits may need adjustment.	Refer to the operator owner's manual to readjust limits.
		Sprocket on limit shaft may be slipping or limit drive chain may be broken.	Ensure sprocket key is correctly installed and set screws are tightened. Contact Service for replacement chain if broken.
Limit switch may be defective.		Contact Service.	
Limit Switches	Limit switch does not hold setting	Drive chain may be too loose, allowing the chain to jump sprocket teeth.	Adjust chain to proper tension. Contact Service for additional information.
		Limit nut retainer not engaging slots in limit nuts.	Be sure retainer is securely engaged in slots of both limit nuts.
		Limit nuts binding on screw threads, allowing them to jump position on retainer.	Lube screw thread. Check that limit nuts turn freely.

Section 7 – Installation Instructions

NOTE: Read all instructions carefully, checking shop drawings supplied for any special conditions. Open all crated materials and check for damaged or missing parts prior to installation.

NOTE: Proper operation is a direct result of proper installation. To ensure that your SentryGate™4 will function at it's maximum potential, work to minimal tolerances when leveling sill and establishing distance between guides.

NOTE: Left hand (LH) or right hand (RH) of the unit is taken as you face the door opening from the coil side of the unit.

NOTE: Refer to hardware list provided to identify fasteners supplied.

1. Inspection:

Establish opening width and height and check against the opening size shown on the shop drawings.

Check sill and level if necessary.

2. Install guide assemblies:

Figure 2-1 shows three types of guide configurations.

Figure 2-1

A: FACE OF WALL

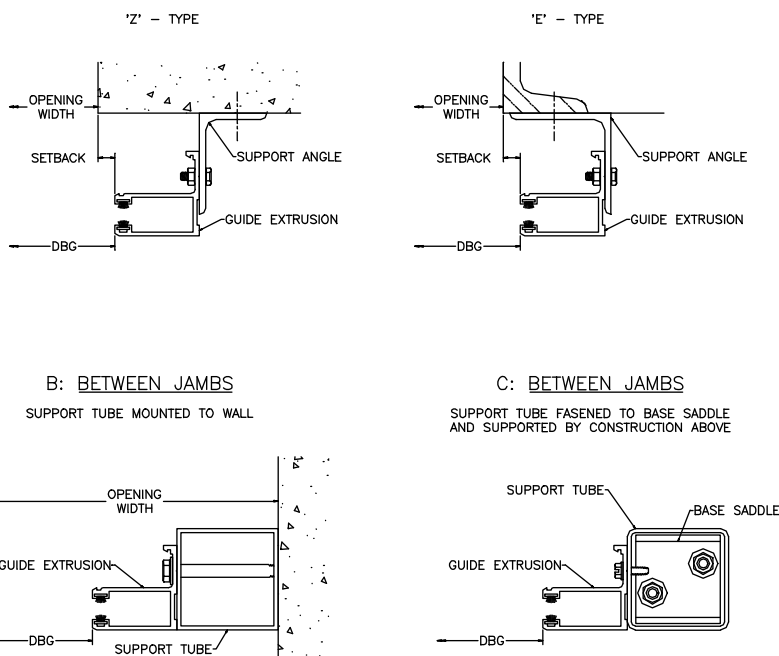

A. Face of wall ('E' or 'Z')

B. Between jambs with support tube mounted to jamb.

C. Between jambs with support tube fastened to base saddle and supported by construction above.

Section 7 – Installation Instructions

If guide is type [A] or [B]:

1. Set left hand guide support in place according to the guide detail and plumb.
2. Mark hole locations on wall and remove guide support.
3. Drill and prepare holes for wall fasteners.
4. Return the guide support into position and install wall fasteners securing guide in place.
5. Measure from the lh guide assembly the distance between the guide supports and make a reference mark for locating the rh guide support.
6. Place the rh guide support on the reference mark, plumb and level with respect to the lh jamb.
7. Repeat steps 2 through 4 for the rh guide support.

If guide is type [C]:

1. Position left hand guide support according to guide detail.
2. Mark support tube location on floor and remove support tube.
3. Center base saddle on support tube location marks. Mark floor for saddle fasteners and remove base saddle
4. Drill and prepare holes for saddle fasteners.
5. Return base saddle and secure in place.
6. Position guide support tube over the base saddle and plumb.
7. Secure top of support tube to construction above. Unless a length is specified, steel tubes are supplied in 20' lengths (aluminum tubes in 14' lengths) and are to be fitted at time of installation.
8. Measure from the lh guide assembly the distance between the guide support tubes and make a reference mark for locating the rh guide support tube.
8. Place the rh guide support tube on the reference mark.
9. Repeat steps 2 through 7 for the rh guide support tube.

3. Preparation for hood support mounting:

If a hood is supplied with more than one section, a hood support is required. It is advisable to locate the hood support(s) prior to shaft assembly installation because, when installed, the shaft assembly limits access and makes it difficult to prepare holes for hood support attachment. Refer to Part 12 for specific instructions.

4. Shaft positioning:

Check the markings on the shaft assembly. The adjustor side will be labeled "LH ADJUST" or "RH ADJUST". Position the shaft assembly according to these markings and hoist the shaft assembly approximately 2 or 3 feet above floor for ring installation. Note: Left hand or right hand is taken as you face the door opening from the coil side of the unit.

Section 7 – Installation Instructions

5. Ring installation (4" pipes only):

Figure 5-1 shows the proper orientation of the ring on the shaft assembly.

Figure 5-1

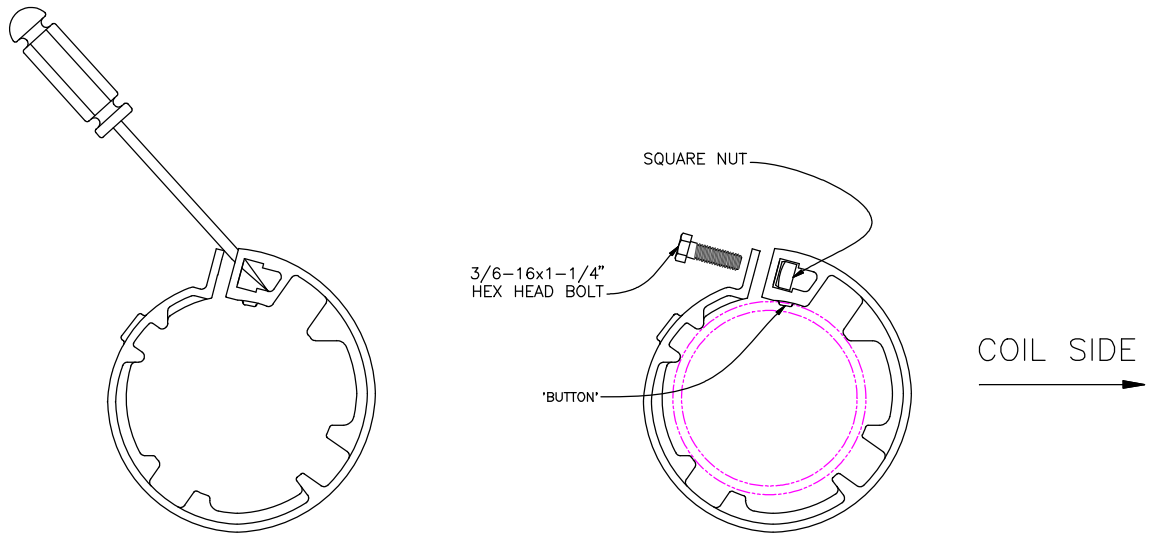

1. Spread the ring enough to allow it to slip onto the shaft assembly by inserting a screwdriver into the closed portion of the cast iron ring as shown in Figure 5-1.
2. Slide ring into position on the shaft assembly so that the 'button' falls into the pre-drilled locator hole.
3. Install the 3/8-16 x 1-1/4" hex head bolt through holes in ring and into the square nut in recess.
4. Be sure that the ring is square on the shaft and tighten hex bolt until ring clamps securely to the shaft assembly.
5. Repeat steps 1 through 4 until all rings are installed.

Note: A 3/8-16 x 3/4" hex head bolt and a 3/8" flat washer are included in the ring hardware package for each ring to be used later for curtain attachment.

6. Bracket and Shaft installation:

Figure 6-1 through Figure 6-4 show the available shaft configurations. Identify the type of shaft assembly supplied and follow the instructions for that style of shaft.

Note: Figure 6-1 through Figure 6-4 show a right hand operator / left hand adjustor as viewed from the coil side of the unit.

Section 7 – Installation Instructions

Figure 6-1

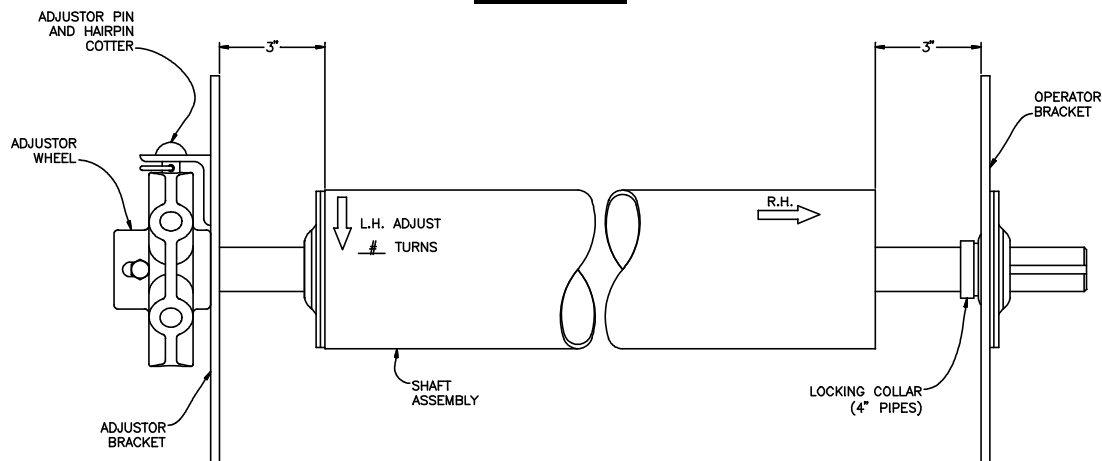

OUTSIDE ADJUST / OUTSIDE GEAREND
(4" AND 6" PIPES)

If shaft is outside adjust / outside gearend:

1. Remove adjustor wheel (if necessary).
2. Slide adjustor bracket plate onto shaft.
3. Reinstall adjustor wheel.
4. Install adjustor pin through clip angle to align adjustor wheel.
5. Fasten adjustor wheel securely to the shaft and remove the adjustor pin.
6. Slide operator bracket onto shaft and locate inside of bracket plate 3" from the edge of the pipe.
7. On 4" pipes, slide locking collar until shoulder engages the flange bearing on the bracket plate. It may be necessary to rotate collar to get it to fully engage the flange bearing. Using a hammer and a punch, rotate the collar until it locks the bearing to the shaft. Tighten setscrew on collar.
8. For chain or crank operated units, slide driven sprocket onto shaft and align with drive sprocket from the operator. Tighten setscrews on sprockets. Install roller chain and adjust chain tension. Tighten operator mounting bolts securely.
9. Refer to Figure 6-5 for bracket position on support. Hoist shaft assembly with brackets into place. Fasten bracket plates to guide supports using bracket mounting hardware provided.

Section 7 – Installation Instructions

Figure 6-2

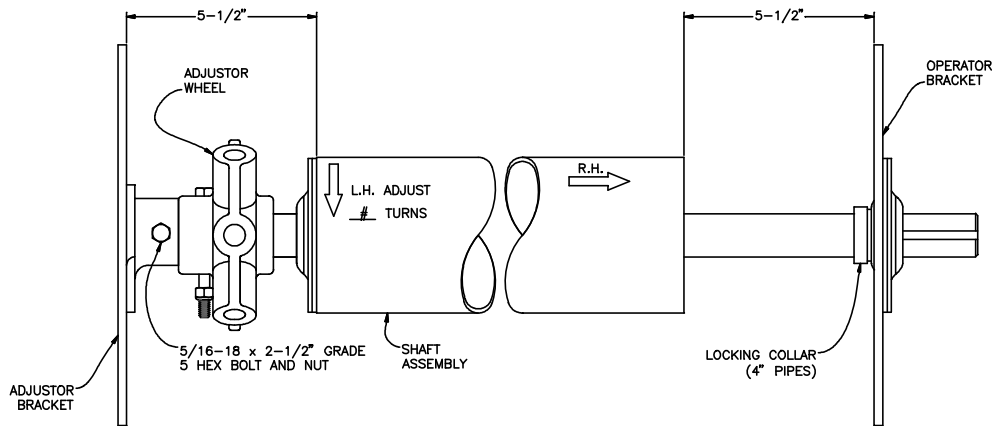

INSIDE ADJUST / OUTSIDE GEAREND
(4" PIPES)

If shaft is inside adjust / outside gearend:

1. Remove 5/16-18 x 2-1/2" hex head bolt and nut from adjustor bracket lug.
2. Install adjustor bracket to guide support using bracket mounting hardware provided. Refer to Figure 6-5 for bracket position on support.
3. Slide operator bracket onto shaft and locate inside of bracket plate 5-1/2" from the edge of the pipe.
4. On 4" pipes, slide locking collar until shoulder engages the flange bearing on the bracket plate. It may be necessary to rotate collar to get it to fully engage the flange bearing. Using a hammer and punch, rotate the collar until it locks the bearing to the shaft. Tighten setscrew on collar.
5. For chain or crank operated units, slide driven sprocket onto shaft and align with drive sprocket from the operator. Tighten setscrews on sprockets. Install roller chain and adjust chain tension. Tighten operator mounting bolts securely.
6. Hoist shaft assembly with operator bracket and place adjustor side of shaft into adjustor bracket lug. Reinstall 5/16-18 x 2-1/2" hex head bolt into adjustor bracket lug and through shaft temporarily to keep shaft from slipping out of adjustor lug. Fasten operator bracket plate to guide support using bracket mounting hardware provided.

Section 7 – Installation Instructions

Figure 6-3

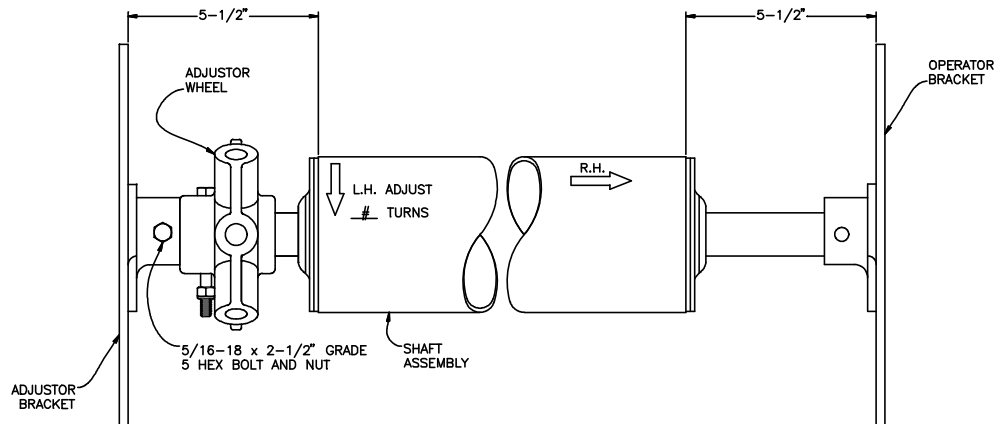

INSIDE ADJUST / INSIDE GEAREND
(4" PIPES)

If shaft is inside adjust / inside gearend (push-up operation only):

1. Remove 5/16-18 x 2-1/2" hex head bolt and nut from adjustor bracket lug.
2. Install brackets to guide supports using the bracket mounting hardware provided. Refer to Figure 6-5 for bracket position on support.
3. Hoist shaft assembly and place into bracket lugs. Reinstall 5/16-18 x 2-1/2" hex head bolt into adjustor bracket lug and through shaft temporarily to keep shaft from slipping out of adjustor lug.

CAUTION: The gearend of the shaft assembly is not fastened to the bracket lug. When positioning shaft assembly, be careful not to shift gearend out of lug.

Section 7 – Installation Instructions

Figure 6-4

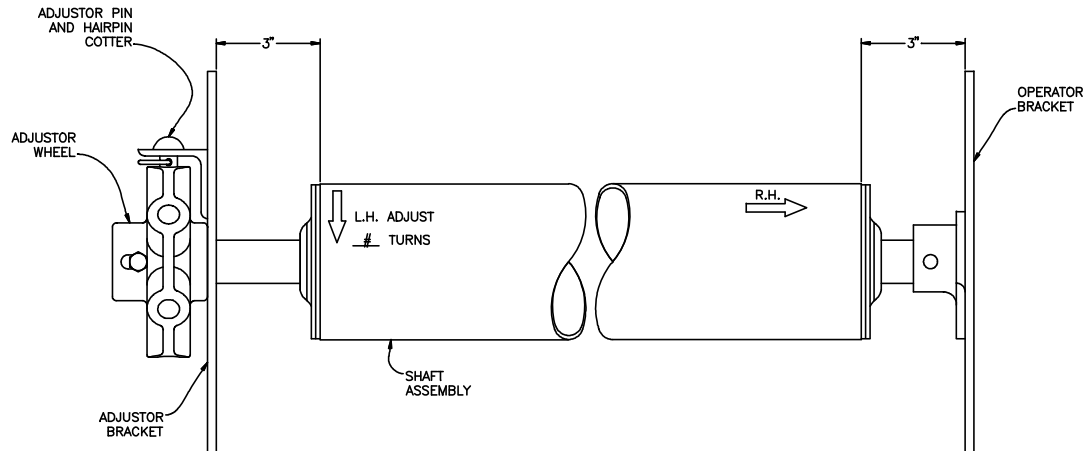

OUTSIDE ADJUST / INSIDE GEAREND
(4" PIPES)

If shaft is outside adjust / inside gearend (push-up operation only):

1. Remove adjustor wheel (if necessary).
2. Slide adjustor bracket plate onto shaft.
3. Reinstall adjustor wheel.
4. Install adjustor pin through clip angle to align adjustor wheel.
5. Fasten adjustor wheel securely to the shaft and remove the adjustor pin.
6. Install operator bracket plate to guide support using bracket mounting hardware provided. Refer to Figure 6-5 for bracket position on support.
7. Hoist shaft assembly with adjustor bracket and place operator side of shaft into operator bracket lug. Fasten adjustor bracket plate to guide support using bracket mounting hardware provided.

CAUTION: The gearend of the shaft assembly is not fastened to the bracket lug. When positioning shaft assembly, be careful not to shift gearend out of lug.

Section 7 – Installation Instructions

Figure 6-5 shows the proper bracket position on a guide support.

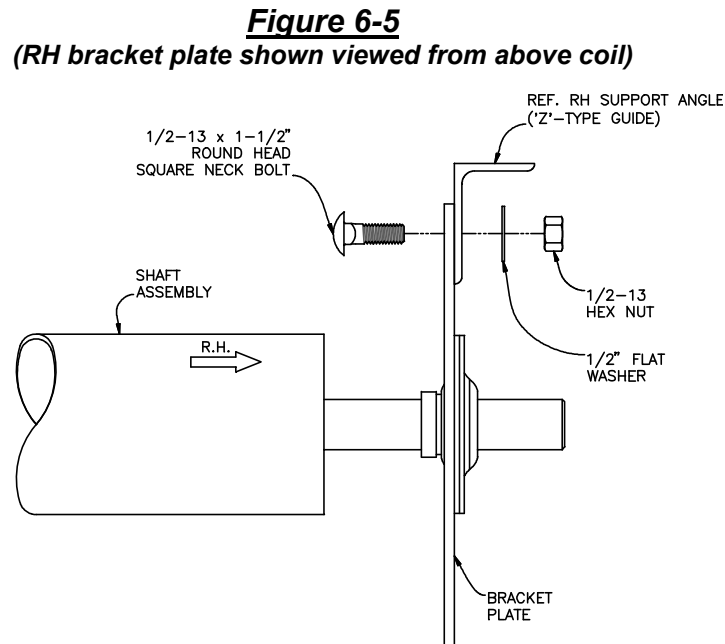

1. Bracket plate is mounted on inside of guide support angle / tube.
2. Heads of bracket fasteners are located on the inside of the bracket plate.

CAUTION: Be sure that the heads of all bracket mounting fasteners are located on the inside of the bracket plate. Curtain damage may occur during operation if bracket hardware is mounted incorrectly.

7. Motor Installation (motor operated units only):

1. Install motor operator as shown on the motor arrangement drawing supplied in the motor carton.
2. Slide driven sprocket onto shaft and align with drive sprocket from the motor. Tighten setscrews on sprockets. Install roller chain and adjust chain tension. Tighten motor mounting bolts securely.
3. Brace/support motor to existing construction to limit motor movement. Cornell provides bracing angles for standard installations. Installer is to provide additional support/bracing if required for adequate support.
4. Follow manufacturer's instructions and reference wiring diagrams included with operator when making electrical connections (coil cord, reelite, interlocks, sensing edge, etc.)

Section 7 – Installation Instructions

8. Curtain Installation:

Refer to Figure 8-1 for the proper orientation of the curtain as it attaches to the shaft assembly.

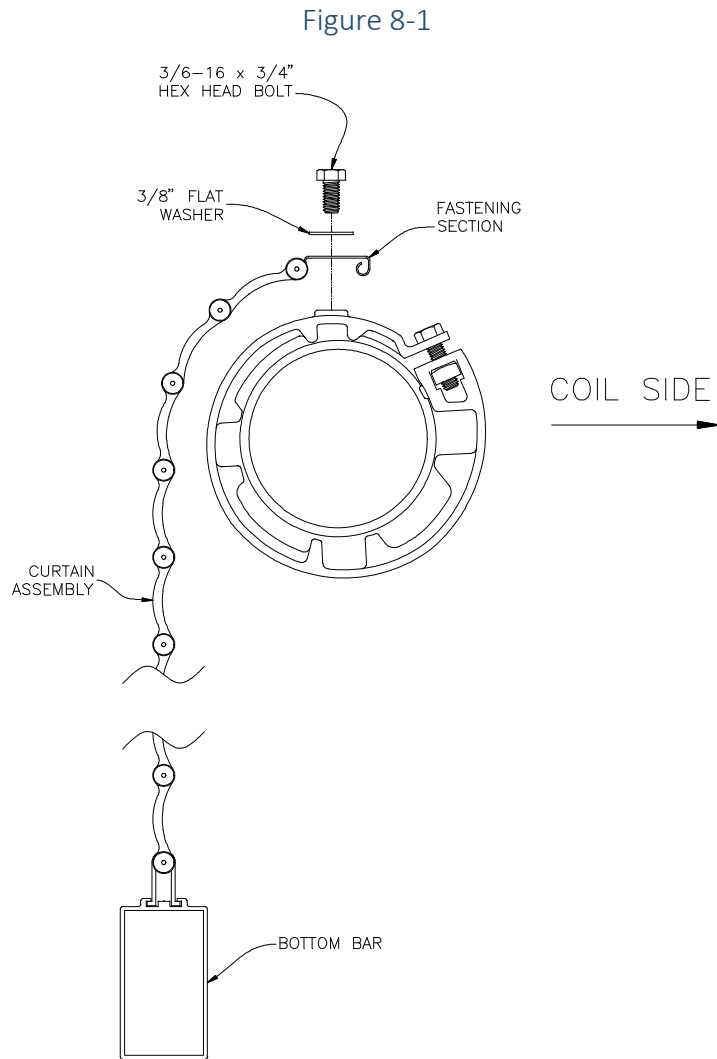

1. Position rolled curtain at base of guides.
2. Hoist curtain and attach the curtain fastening sections to the rings using the 3/8-16 x 3/4" hex head bolts and 3/8" flat washers supplied in the ring hardware packages. On a unit with a 6" pipe, fastening sections are directly attached to the shaft assembly with a 3/8-16 x 5/8" hex head bolt and 3/8" flat washer.
3. Uncoil curtain and allow bottom bar to sit on the floor.

Section 7 – Installation Instructions

9. Apply spring charge:

There are 2 general types of spring adjustor wheels:

1. Outside adjust (Figure 6-1 and Figure 6-4).
2. Inside adjust (Figure 6-2 and Figure 6-3).

Determine the type of adjustor and follow the corresponding instructions below.

WARNING! Serious injury or death may occur. Components are under extreme spring tension. Adjustments should be made by qualified installers only.

WARNING! Do not stand in front of adjusting wheel while charging springs. Serious injury can result should a rod slip during the spring charging process.

Outside Adjust: (Refer to Figure 9-1)

Figure 9-1
(Left hand adjustor shown.)

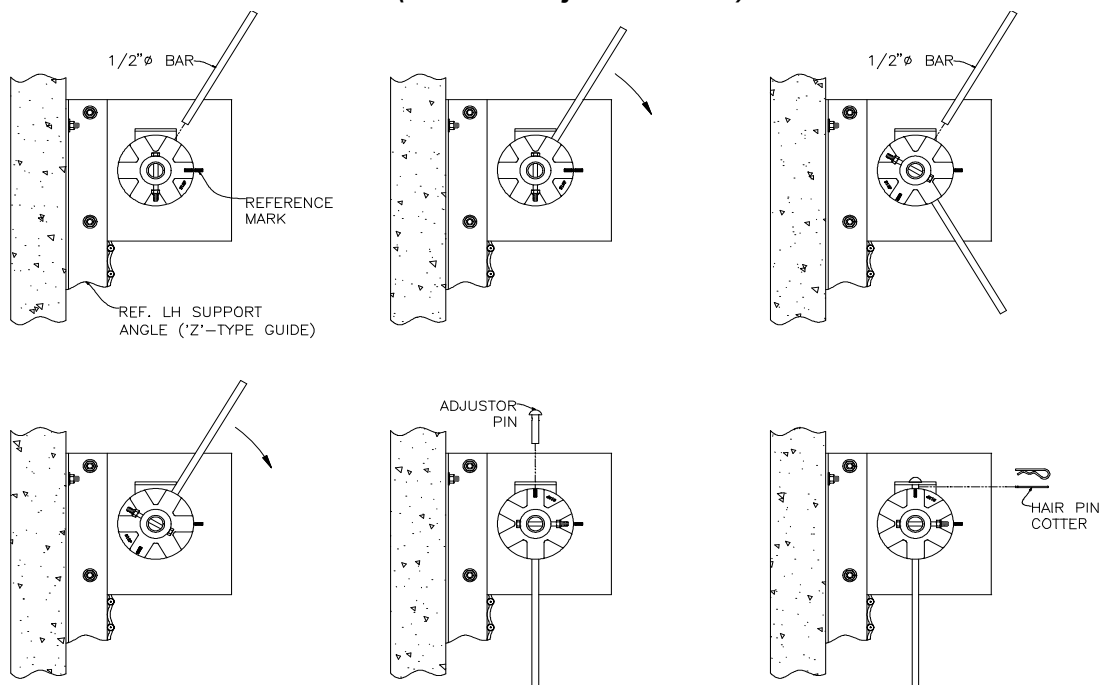

1. Place a mark on the edge of the adjusting wheel and a corresponding mark on the bracket plate to be used as a reference when counting the number of turns applied.
2. Insert a 1/2" rod into one of the pockets of the adjusting wheel and turn the wheel in the direction of raising the door. Insert a second rod into a pocket near the top of the adjusting wheel and remove the first rod. Turn the wheel in the same direction as before. Continue this process until the number of required turns is applied. The number of required turns is labeled on the adjustor side of the shaft assembly. This number represents the number of turns required with the curtain in the closed position. It may be necessary to partially raise the curtain as it becomes increasingly difficult to apply spring tension.

Section 7 – Installation Instructions

WARNING! When applying spring tension, it is important that the curtain assembly is sufficiently secured to prevent it from running into the coil area.

3. Insert adjustor pin through hole in clip angle on adjustor bracket and into a pocket of the adjusting wheel. Insert hair pin cotter into hole in adjustor pin.

Inside Adjust: (Refer to Figure 9-2)

Figure 9-2
(Left hand adjustor viewed from coil side of unit.
Wall and curtain not shown for clarity.)

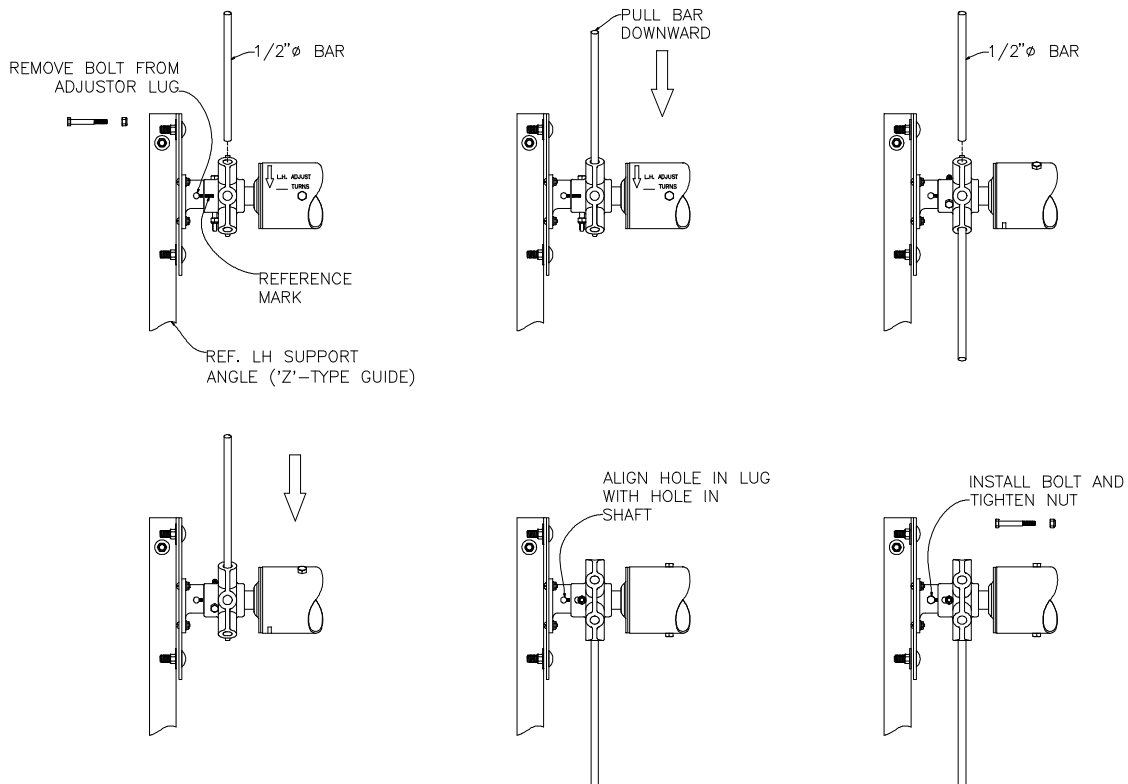

1. Remove 5/16-18 x 2-1/2" hex head bolt from adjustor bracket lug.
2. Place a mark on the edge of the adjusting wheel and a corresponding mark on the bracket lug to be used as a reference when counting the number of turns applied.
3. Insert a 1/2" rod into one of the pockets of the adjusting wheel and turn the wheel in the direction of raising the door. Insert a second rod into a pocket near the top of the adjusting wheel and remove the first rod. Turn the wheel in the same direction as before. Continue this process until the number of required turns is applied. The number of required turns is labeled on the adjustor side of the shaft assembly. The curtain may have a tendency to rise as spring tension is applied therefore; it may be necessary to hold the curtain in the closed position until all spring tension is applied.
4. Install 5/16-18 x 2-1/2" hex head bolt through hole in bracket lug and inner shaft. Attach nut and tighten.

Section 7 – Installation Instructions

10. Attach guide extrusions:

1. Raise curtain to the open position and secure temporarily to prevent curtain from over coiling.
2. Flare the top of each guide extrusion as shown in Figure 10-1.

Figure 10-1

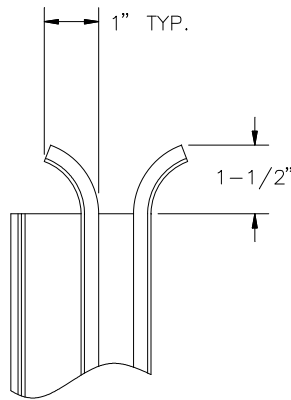

3. Install the guide extrusions so that the curtain and the bottom bar are captured in the guide gap.
4. Fasten the guide extrusions securely to the guide supports using the assembly fasteners provided.
5. Position stoppers using the pre-drilled holes and tighten fasteners.
6. Remove any clamps or other devices used to temporarily hold curtain and allow bottom bar to rest against stoppers.

NOTE: Do **not** install snap-on guide trim (if supplied) until operation is checked and adjustments are made.

11. Check operation:

1. Operate curtain to full closed and full open position several times and check balance of springs. Add or remove spring tension as required.

CAUTION: Do not add more than one full turn of spring tension. This may reduce spring life and result in premature shaft failure.

2. Check alignment of sprockets and chain tension. Adjust as necessary.
3. Check all mounting hardware for secure attachments.
4. Check locking mechanism to be sure locks operate properly and without binding. Adjust lock strike if necessary by loosening the pan head screw and sliding the lock strike until the slide bolt is centered in the slot.

Section 7 – Installation Instructions

12.1. Hood Support Prep and Installation:

1. Refer to the job information to determine the type and quantity of hood supports required for your door. Hood supports will be noted on the elevation view of the job construction drawings. See **Figure 12.1** for hood support types.

Figure 12.1 - Hood Supports

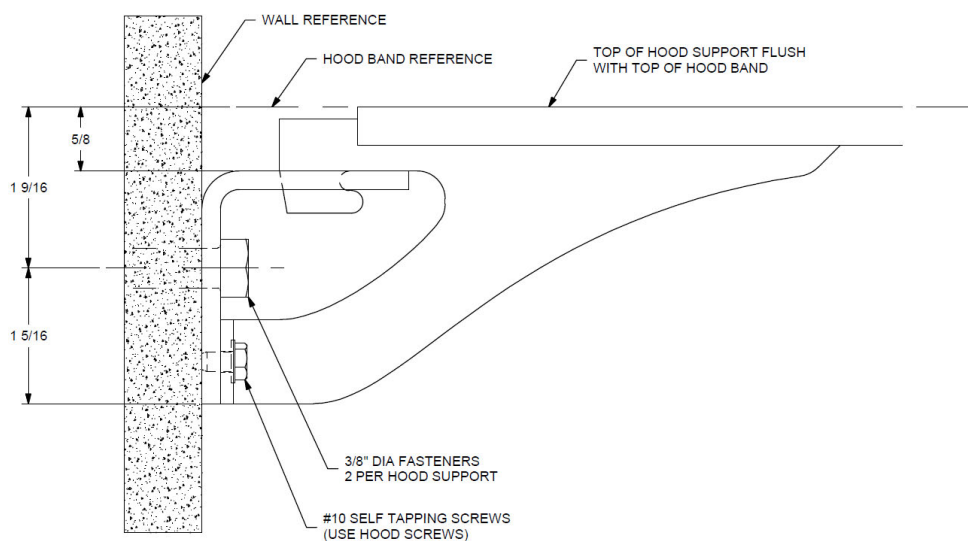
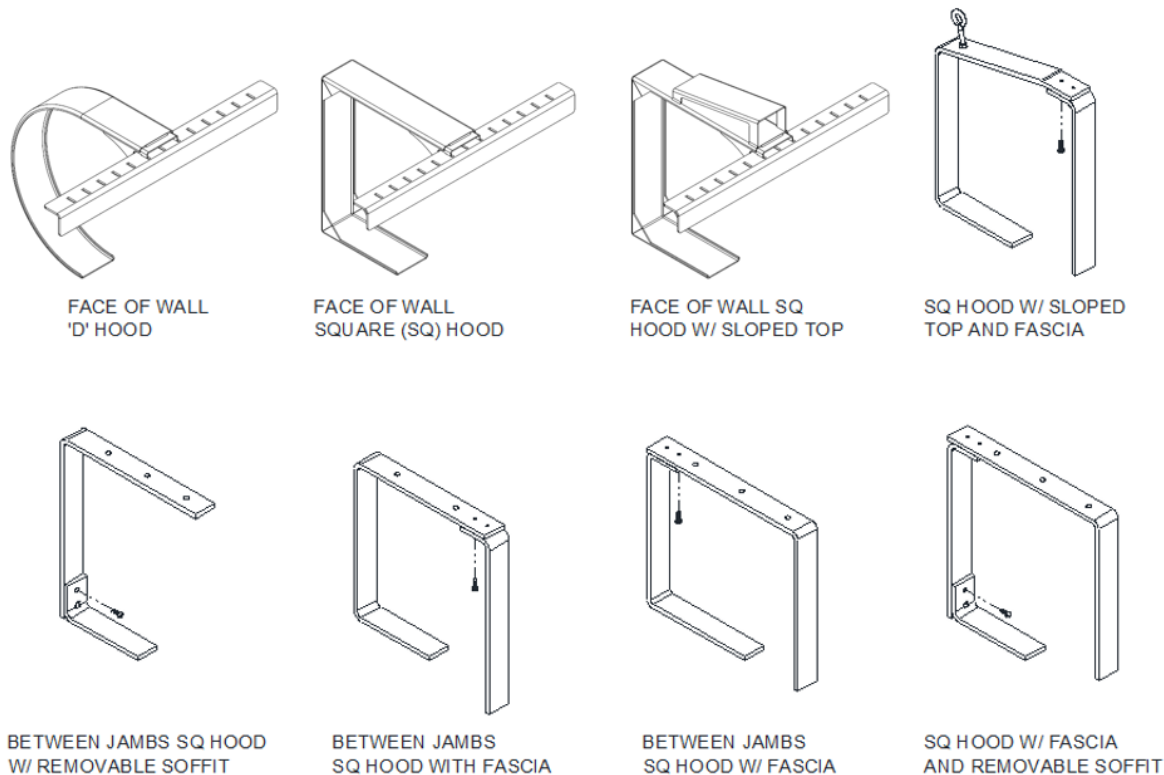

Note: See above detail for face of wall units; the wall angle is offset 5/8" from top of hood band to allow hood support to be flush while installing the hood.

Section 7 – Installation Instructions

2. Determine where the support(s) will be located between the guides.
 - a. If multiple supports are required, see the job construction drawings to determine the centerline of each.
 - b. If a single support is required, it will be located at the center of the unit.
3. Mark a line on the lintel at the centerline of each support.
4. Check the construction at the support locations to be sure it is strong enough to handle the weight of the hood.

Note: *If the construction is not strong enough, do not proceed until rectified.*

5. The term "top of coil" refers to the top edges of the brackets or hood band, see **Figure 12.1.1**
 - a. If there is a ceiling at the top of the coil, skip the next step.

Figure 12.1.1 – Top of Coil

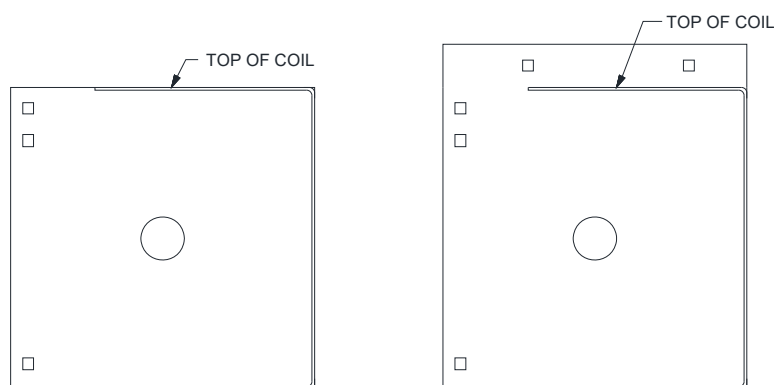

6. Mark a line at the top of the coil at both guides of the unit. Project the lines together to make a continuous line.
 - a. This will help locate the top of the hood support which will keep the hood level.
7. Project a line from the fascia mounting location (fascia mounting channel or fascia side of the tube) from one guide to the other.
8. Mark a line at the support centerline along the fascia line.
9. Prepare the location of the attachment point of the support(s) prior to installing the barrel. This will make installing the support much easier when the time comes to attach it to the lintel/header or ceiling.
 - a. Hold the support in place at the determined location and mark the mounting hole locations.
 - b. Drill holes in the construction and hood support mounting angle.
10. Attach the hood support mounting angle to the lintel/header or ceiling to be sure the mounting holes were located properly.
11. Once the barrel, brackets, curtain are installed, and necessary testing was done on the unit, re-install the hood support.

Section 7 – Installation Instructions

12.2 Hood and Fascia Installation

1. Determine what type of hood is provided. See **Figure 12.2** for possible hood configurations. This can be done by:
 - Looking at the brackets and identifying a half-circle shaped flat (D-shaped hood) or straight flats (square or sloped).
 - Looking in the hood box and comparing to the job construction drawings.

Figure 12.2 – Hood Configurations

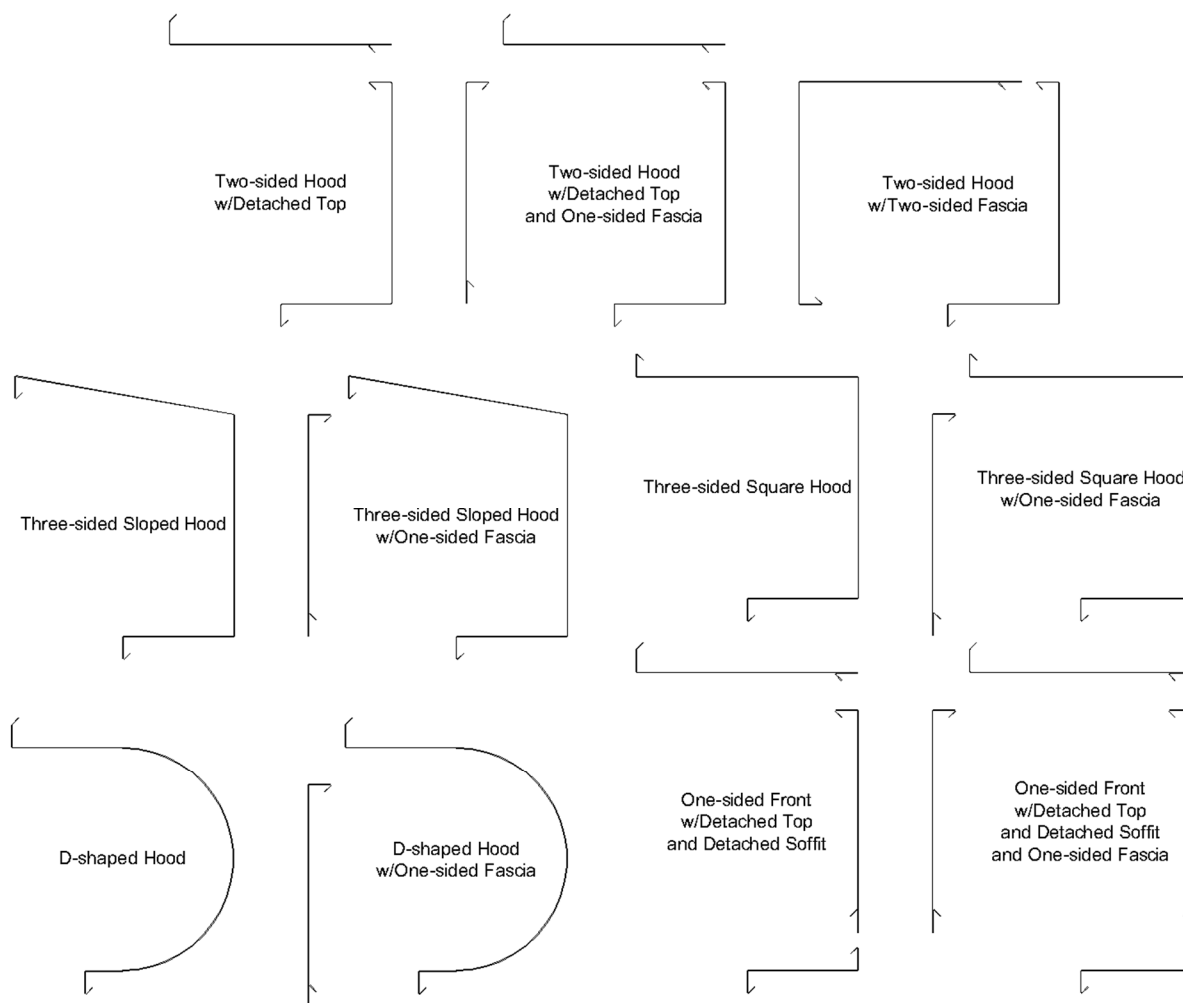

1. If no fascia is included, skip to Step 3.

If a fascia is included, it will be installed first. Fascia fastening varies by job condition but is typically secured to the guides, the brackets, or to the wall. Install the right-most section first, ending in “-R”. Continue leftward adding fascia sections, overlapping the right-hand section by 4”

Section 7 – Installation Instructions

2. If the hood has more than one section (separate left, right, or center), skip to Step 5.

For single-section hoods, begin with the front-most piece. Install by holding the hood up to the coil area and pushing it against the flats on the brackets. Center the hood so the gap is the same at both brackets. Pre-drill with a #21 or 5/32" drill in at least one place on every face of the hood, at both the left and right sides. See **Figure 12.4** for recommended fastener locations.

3. After fastening the first hood piece, continue with the detached soffit and top, if included.
4. For hoods with multiple sections, begin with the front-most right-hand hood piece, ending in "-R".

Install by holding the hood up to the coil area and pushing it against the flats on the brackets. Butt the hood piece against the bracket to minimize the gap. Pre-drill with a #21 or 5/32" drill in at least one place on every face of the hood, at both the left and right sides. See **Figure 12.4** for recommended fastener locations.

The hood section should cover the hood support completely (approx. 4"). Temporarily clamp hood section to hood support until the next section is installed.

5. Continue leftward installing sections of the same type of hood piece before starting with the right-most soffit or top pieces. See **Figure 12.3** for an example of the order hood pieces should be installed. No cover is used on the splice between hood sections.

Figure 12.3 – Multiple Hood Sections

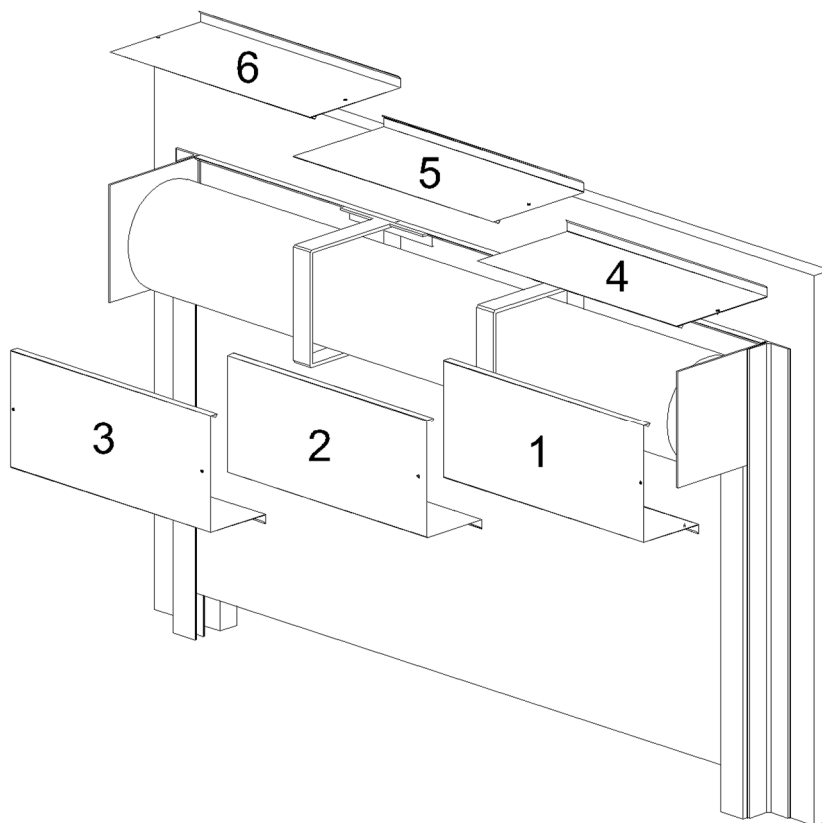

Section 7 – Installation Instructions

Figure 12.4 – Recommended Fastener Locations

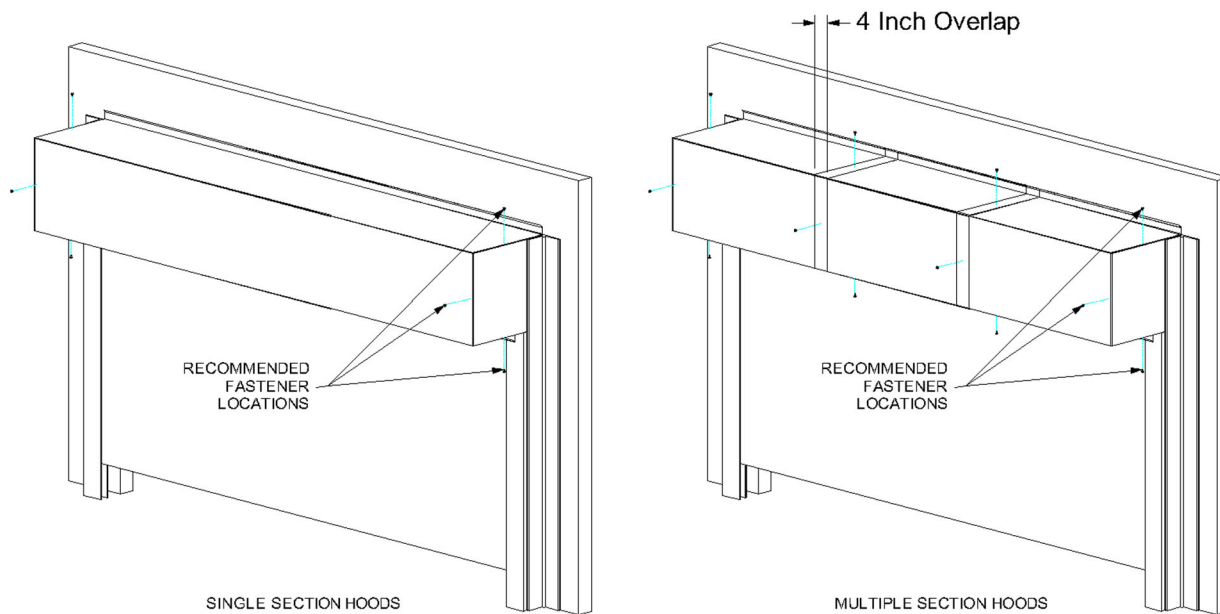

6. If the door is mounted in a weathered or exterior location, caulk the part of the hood that contacts the wall.

13. Snap-on guide trim installation (if supplied):

Refer to Figure 13-1 for installing the snap-on guide trim.

Section 7 – Installation Instructions

Figure 13-1
(LH guide shown as viewed from above)

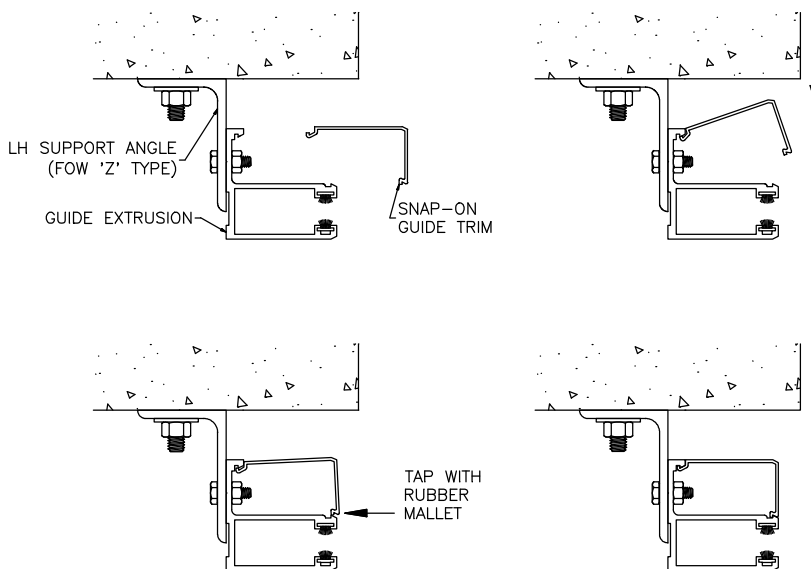

1. Insert the locking hook on the large edge of guide trim into the guide extrusion.
2. Rotate snap-on trim until short edge contacts the guide extrusion.
3. Using a rubber mallet, tap trim until it snaps into the locked position.

14. Guide mounted interlock installation (if supplied):

Guide mounted interlocks are installed in pairs (lh and rh) on motor operated units with bottom bar locking (unless motor is equipped with an MMI-motor mounted interlock). Refer to figure 14-1 for installation.

Figure 14-1
(RH interlock shown)

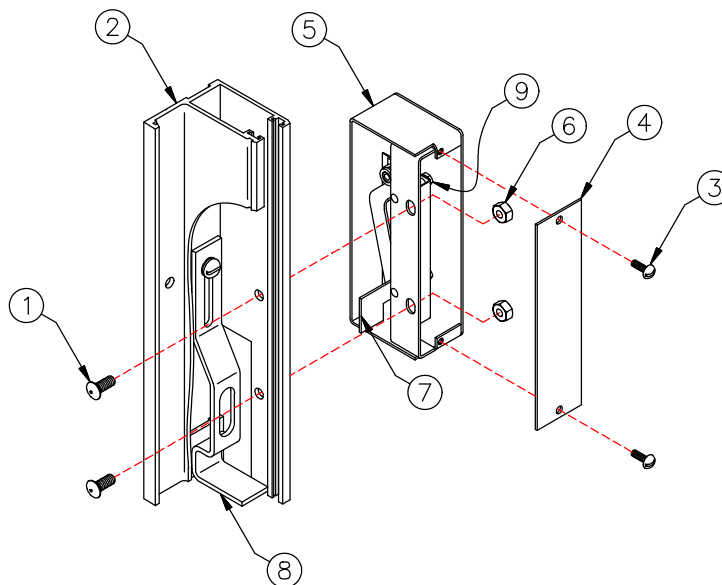

Section 7 – Installation Instructions

1. Raise curtain to the open position.
2. Insert two 1/4-20 x 5/8" round head ribbed neck bolts (1) into pre-drilled holes in the rh guide extrusion (2).
3. Remove the faceplate screws (3) and the interlock switch faceplate (4).
4. Place interlock switch (5) onto mounting bolts and install two 1/4-20 hex nuts (6). Be sure that the interlock paddle (7) is positioned behind the lock strike (8).
5. Adjust interlock paddle by loosening two 11mm hex nuts (9) securing the interlock mechanism to the interlock body. Paddle should be centered on the hole of the lock strike. Tighten mechanism to interlock body.
6. Lower curtain to the fully closed position. Check to see if the bottom bar lock trips the interlock switch. Interlock switch should make an audible "click" if functioning correctly. If interlock switch does not "click", adjust micro-switch as necessary and retest.
7. Repeat steps 1 through 6 for the lh guide.
8. Connect interlocks to the motor operator in series. Refer to motor operator schematic.
9. Re-install interlock switch faceplates.