

***Installation Instructions,  
SentryGate 3***

**Section 1 – Table of Contents**





<b>Section 2 – Safety Check List</b>	<b>2</b>
<b>Section 3 – Freight Receiving</b>	<b>3</b>
<b>Section 4 – Pre-installation</b>	<b>4</b>
<b>Section 5 – Torque Specifications</b>	<b>5</b>
<b>Section 6 – Maintenance Schedule</b>	<b>6</b>
<b>Section 7 – Installation Instructions</b>	<b>9</b>

## Section 2 – Safety Check List

Rolling doors are large, movable objects. They move with the help of electric motors or manual operators (chain, crank, push up, etc), and most have springs under high tension. These items and their components can cause injury. In order to avoid injury to yourself and others, please follow the instructions in this manual.

- Review the potential hazards and preventative measures listed below:

**Table 2.1 - Potential Hazards and Preventative Measures**

Potential Hazard		Preventative Measure
	<b>⚠ DANGER</b> <b>Pinned or crushed by closing door.</b>	<ul style="list-style-type: none"> <li>• Keep yourself and others clear of opening while door is in motion.</li> <li>• Do not allow children to play near or operate door.</li> <li>• Do not operate if door becomes jammed or broken.</li> </ul>
	<b>⚠ WARNING</b> <b>Struck by adjusting wheel bar while applying spring turns.</b>	<ul style="list-style-type: none"> <li>• Be sure bar is adequate in strength and long enough to allow installer to apply the necessary torque.</li> <li>• Make sure bar is fully seated into the adjusting wheel slot before applying pressure.</li> <li>• Use two bars while applying turns to the adjusting wheel.</li> </ul>
	<b>⚠ WARNING</b> <b>Electrical shock.</b>	<ul style="list-style-type: none"> <li>• Make sure electrical operator is properly grounded.</li> <li>• Turn off source power completely prior to servicing the motor.</li> <li>• Make sure wires are clear of any moving or potentially moving parts.</li> <li>• Avoid pinching wires when installing the motor cover.</li> </ul>
	<b>⚠ WARNING</b> <b>Pinched by moving components.</b>	<ul style="list-style-type: none"> <li>• Make sure the motor is turned off and unplugged before working with moving parts such as roller chain and sprockets, drop-out mechanisms, adjusting wheels, etc.</li> <li>• Locate the possible pinch-points of the unit (Drive chain, coil area, bottom bar, etc.) Do not operate the door while someone is near these areas.</li> </ul>

- **Check the following during installation and before leaving the job site:**
  - a. If the unit has tension springs, be sure the proper amount of tension is applied to the torsion springs, in order to properly counterbalance the weight of the curtain.
  - b. Securely fasten the tension adjusting wheel in place with the appropriate hardware provided.
  - c. Check that the keys and/or cotter pins have been set in place and fit properly at all sprockets or gears.
  - d. Check that the setscrews in each sprocket or gear (one over the key and one offset from the key) have been tightened properly.
  - e. Check all fasteners holding the unit to the building structures.
  - f. Check all fasteners used to assemble the components of the unit together.
  - g. Instruct owner or representative in the proper method of operating the door.

### Section 3 – Freight Receiving

- **Upon delivery, check condition of components for damage.**
- **If damage occurred in transit, the installation should not proceed without authorization.**

#### **NOTICE**

If the installation proceeds, neither the carrier nor the manufacturer will assume responsibility for replacing the damaged material.

- **If the installation is stopped due to damage, do the following:**
  1. Take pictures of the damage.
  2. Do not move material from point of delivery to other premises once the damaged components are discovered.
  3. Do not unpack, if the damage is visible prior to removing packaging, until an inspection is made.
  4. If the damage is found while removing contents from packaging, the packaging material must be saved until inspection is made.
  5. Container and packaging should be retained by consignee until inspection is made.
  6. Have components inspected by carrier's representative within 15 days from date of delivery.
  7. Consignee must obtain a copy of the Inspection Report.
- **Returning damaged components:**
  1. Obtain permission from carrier to return.
  2. Route the return shipment via the identical carrier(s) involved in the original shipment.
  3. Notify the manufacturer when shipment is returned to manufacture plant.
- **Verify that all components have arrived. Look for the following:**
  1. Job construction drawings featuring different views (elevation, section, plan, etc.)
  2. (2) Guide assemblies; check for guide weathering if included in order
  3. Barrel assembly
  4. Curtain assembly with bottom bar attached
  5. (2) Bracket assemblies
  6. Operator; if not attached to bracket
  7. Operator cover; may not be included in order
  8. Adjusting wheel; if the barrel assembly contains springs
  9. Inertia brake; typically on units with springless barrel assemblies
  10. Hood and hood supports; may not be included in order
  11. Hardware
  12. Misc. items (Reelite, lintel seal, hood baffle, etc.)
  13. Verify material/finish/color of components matches what is listed on the job construction drawings and/or what was ordered.
- **If the delivery is incomplete:**
  1. Make note on delivery receipt.
  2. Note should be verified by driver's signature.
  3. Notify carrier and manufacturer.

## Section 4 - Pre-installation

- **Read entire instruction manual thoroughly. The manufacturer will not be held responsible for any charges incurred due to improperly installed components.**
  - a. Only trained door systems technicians should perform installation, maintenance, etc.
  - b. Each unit comes with an individual item number. If the job contains multiple units, be sure to locate all the components for each item and separate each.

### **⚠ WARNING**

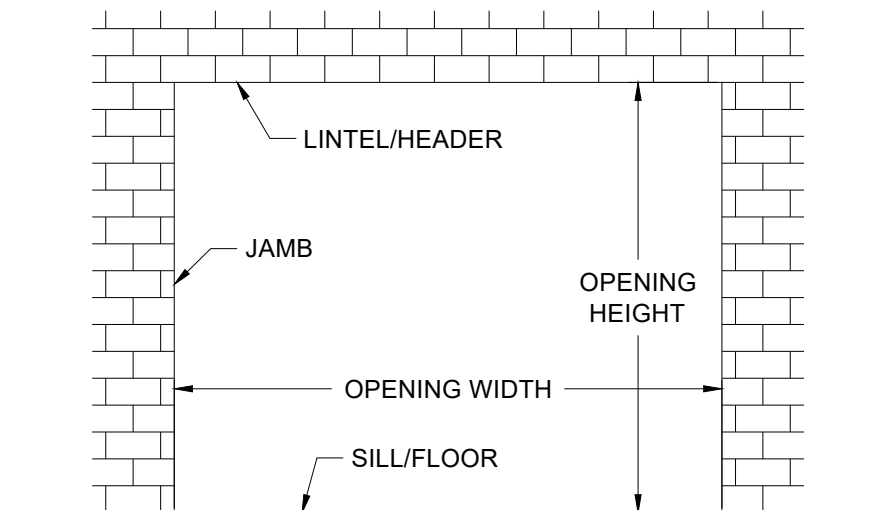
**Do not** interchange parts from one door to another.

- c. Find the job construction drawings for the unit being installed and check the dimensions of the opening against those on the drawings. See **Figure 4.1** below.
- d. If the opening dimensions differ from those on the drawings, **do not proceed**, check with distributor/manufacturer to be sure the correct door is being installed.
- e. Check the jambs of the opening for plumb. Check the head/lintel and floor for level. If the unit is to be free standing, for example mounted to tubes, check the floor and ceiling for level and for adequate mounting areas at the top and bottom.

**Note:** The floor may not be level if a pitched bottom bar is specified.

- **Work Area:**
  - a. The key to a smooth installation is a clean and well-prepared work environment. Once the components have been inspected and the job construction drawings have been reviewed; lay out the components in the order of installation.
  - b. The opening for the door should be cleaned and inspected for rough surfaces and construction debris.
  - c. Lastly the mounting hardware supplied with the door should correspond with the surface and construction features of the opening.
  - d. The basic assembly sequence is as follows: guides, barrel w/ rings or tapped holes, brackets, motor operator (if applicable), curtain, bellmouth, stoppers, weather stripping, hood, and operator/adjustor/idler covers.

**Figure 4.1 - Opening Dimensions and Designations**



## Section 5 – Torque Specifications

**Table 5.1 – Torque Recommendations for Guide Assembly and Wall Fasteners**

Bolt size/type	Torque (ft lbs) <sup>a</sup>
1/4-20 Grade 2 steel bolt	6
5/16-18 Black Oxide Socket Cap	25
3/8-16 18-8 stainless steel bolt	20
3/8-16 Grade 2 steel bolt	20
3/8-16 Grade 5 steel bolt	31
3/8-16 Grade 8 steel bolt	45
1/2-13 Grade 5 steel bolt	75
1/2-13 Grade 8 steel bolt	107
5/8-11 Grade 8 steel bolt	212
3/4-10 Grade 8 steel bolt	376
<sup>a</sup> The recommended torque for steel bolts is based on a plated bolt that has not been lubricated.	

**Table 5.2 - Torque Recommendations for Solid Masonry Wall Anchors**

Anchor Size (nominal)	Manufacturer/Torque (ft lbs) <sup>a</sup>	
	Simpson Wedge-All	Hilti-Kwik Bolt 3
3/8	30	20
1/2	60	40
5/8	90	85
3/4	150	150
<sup>a</sup> Torque values for grout filled block are different, reference bolt manufacturer for these values.		

## Section 6 – Installation Instructions

▪ **Maintenance Schedule:**

**Note:** If any of the following problems exist, do not operate the door until repaired.

Component	What to look for and how often the components must be inspected:	Weekly	Monthly	Quarterly	What to do if problem exists:
Curtain & Bottom Bar	Are any curtain components damaged (slats, endlocks, etc.)?	X			Contact Service about replacing damaged parts.
	Is bottom bar damaged?	X			Contact Service about replacing damaged parts.
	Are bottom bar fasteners in place and properly tightened?		X		Fasteners must be inspected/replaced and properly tightened.
	Are fasteners attaching curtain to the barrel in place and properly tightened?		X		Fasteners must be inspected/replaced and properly tightened.
	Do you notice any hang-ups, jamming or other problems preventing the door from moving smoothly throughout the opening?	X			Check for external issues, if none exist, contact Service.
	Do you notice any odd or excessive noise when the door is operated?	X			Check for external issues, if none exist, contact Service.
	If there is a bottom seal, is it damaged?		X		Contact Service about replacing damaged parts.
	If there is locking, does it function properly?	X			Check for external issues, if none exist, contact Service.
Brackets	Are brackets plumb and perpendicular with wall?			X	Contact Service.
	Are bracket fasteners in place and properly tightened?			X	Fasteners must be inspected/replaced and properly tightened.
	Do you notice signs of excessive wear on the bearings (i.e. binding, excessive noise, etc.)?		X		If there is a grease fitting, apply grease, if not, contact Service.
	Is adjusting wheel & pin secure?			X	Contact Service.
	Is drive chain sufficiently lubricated?			X	Apply chain lube.
	Is drive chain in need of tightening?			X	Contact Service for instructions on how to tension the chain.
	Is drive or driven sprocket damaged?		X		Contact Service about replacing damaged parts.
Guides	Are wall fasteners in place and properly tightened?		X		Fasteners must be inspected/replaced and properly tightened.
	Are guide assembly fasteners in place and properly tightened?		X		Fasteners must be inspected/replaced and properly tightened.
	Is guide gap dimension correct?		X		Check job construction drawings and adjust gap as required. If job construction drawings are not available, contact Service.
	Are any of the guide parts bent or damaged?		X		Contact Service.

## Section 6 – Installation Instructions

	Are stoppers loose, damaged, or missing?		X		Stoppers must be inspected/replaced and properly tightened.
Hood and Fascia	Is hood/fascia dented or damaged?			X	Remove hood/fascia. Repair if possible. If not leave hood/fascia off and contact Service.
	Is curtain rubbing against the hood/fascia?	X			Hood/fascia may have been damaged. Contact Service.
	Is hood/fascia level?			X	Check fasteners, they may be loose or missing. Replace as soon as possible.
	Are guide assembly fasteners in place and properly tightened?		X		Fasteners must be inspected/replaced and properly tightened.
	Is hood support level?			X	Check fasteners, they may be loose or missing. Replace as soon as possible.
Door operation	Does the door require excessive force to open?		X		Check for hang-ups or obstructions. Ensure spring tension is set correctly. Contact Service.
	If the door contains locking, does the locking mechanism function properly and securely hold the door in the closed position?		X		Check for damage and other external issues. Contact Service.
	If there is a sensing edge, does it function properly?	X			Cut power and check for loose wires. Contact Service for further instruction.
Motor Operator	Are the fasteners attaching the motor-to-the mounting bracket, and mounting bracket-to- the door bracket secure?			X	Fasteners must be inspected/replaced and properly tightened. Contact Service for replacement hardware.
	Are the sprockets properly aligned?			X	Realign the sprockets as secure using the set screws. Recheck chain tension.
	Are the sprocket keys properly aligned with sprockets and securely fastened with the set screws?			X	Reposition the keys so they fully engage the keyway in the sprocket. Tighten the set screws.
	Is the door stopping correctly at the open (before bottom bar contacts the stoppers) and closed (as soon as the bottom bar contacts the floor) positions?		X		Limits may have to be adjusted in the motor operator. Refer to the operator owner's manual or contact Service.
	Is the operator functioning normally?		X		Refer to the <i>Operator Troubleshooting Table</i> on the following page to diagnose the problem.



## Section 6 – Installation Instructions

▪ **Operator Troubleshooting:**

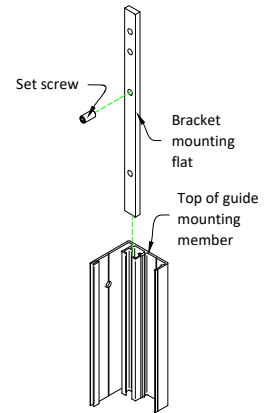
*Note: If you suspect you are having an issue with your operator, use the following table to determine the potential causes. If the provided solution does not eliminate the issue, or the table does not address your particular problem, contact the Service Department.*

Component	Problem	Potential Cause	Solution
Motor Operator	Motor Operator does not run when OPEN or CLOSE button is pushed	The circuit breaker may be flipped or fuse blown.	Reset breaker or replace fuse. Contact Service if replacement fuse is needed.
		The thermal overload may be tripped.	Reset thermal overload.
		Manual interlock switch is open (on units with emergency operator).	Close manual interlocks.
		External interlock may be opened.	Close external interlock.
	Motor operator runs but the door does not move	Sprocket key may be missing or drive chain may be broken.	Contact Service for repair parts. Install key or replace chain.
		Clutch may be slipping.	Adjust if possible. Contact Service otherwise.
	Motor hums but does not run	Door or drive chain may be jamming.	Check for hang-ups or obstructions. Try to operate manually. If issue persists, contact Service.
		Dead phase in 3 phase system.	Check power supply.
		Brake does not release.	Check power to brake solenoid.
		Open motor winding.	Check that all connections are secure.
	Motor operator runs in wrong direction and limits do not function	3 phase operator power supply is out of phase.	Interchange any 2 power leads to unit.
	Door drifts when motor shuts off	Brake may be improperly adjusted or broken.	Check brake components. Contact Service for replacement parts or adjust instructions.
	Motor operator does not shut off at full OPEN or at full CLOSE position	Limits may need adjustment.	Refer to the operator owner's manual to readjust limits.
		Sprocket on limit shaft may be slipping or limit drive chain may be broken.	Ensure sprocket key is correctly installed and set screws are tightened. Contact Service for replacement chain if broken.
Limit switch may be defective.		Contact Service.	
Limit Switches	Limit switch does not hold setting	Drive chain may be too loose, allowing the chain to jump sprocket teeth.	Adjust chain to proper tension. Contact Service for additional information.
		Limit nut retainer not engaging slots in limit nuts.	Be sure retainer is securely engaged in slots of both limit nuts.
		Limit nuts binding on screw threads, allowing them to jump position on retainer.	Lube screw thread. Check that limit nuts turn freely.

## Section 7 – Installation Instructions

**Step 1:** Check the opening size. The SentryGate™3 is made to very close tolerances because of its unique way of “locking” in the guides. It is critical that the distance between guides (DBG) be held within 1/8” to assure proper operation.

**Step 2:** Install bracket mounting flats; refer to Figure 1. Two G340P bracket mounting flats are supplied with each unit; their length equal to coil dimension. Flats are oriented such that the double holes are toward the top. Slide flats into channel of mounting member from top (top of mounting member has mounting hole which is 1-1/2” down from end). Holding top of flat flush with top of mounting member, install 5/16-18 x 5/8” set screw in third hole down of flat and tighten snugly.

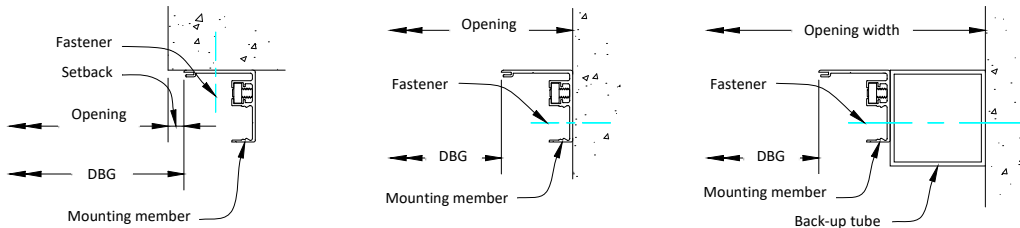


**Figure 1**

**Step 3:** Install mounting members; refer to Figure 2. Two mounting members are supplied, one right hand and one left hand. Figure 2 shows the three standard types of mounting, starting from the left: face of wall (FOW), between jambs (BJ) and between jambs (BJ) with back-up tube. Place left mounting member at desired location on the jamb, plumb and mark jamb at fastener locations.

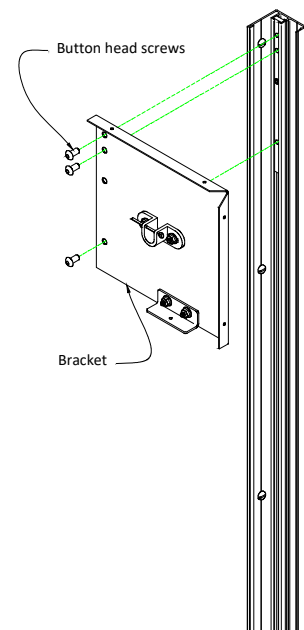
Remove member; drill and prepare holes for wall fasteners. Place member back on jamb, lining up holes in member to those in the jamb, and install wall fasteners tightening them snugly. Measure the DBG from a point on left mounting member as shown in Figure 2 to the same point at which right mounting member will be located and make a reference mark.

Placing right member on jamb at reference mark, plumb and mark at fastener locations. Placing member aside, drill and prepare holes for wall fasteners. Line up right member with holes in jamb and install wall fasteners tightening them snugly.

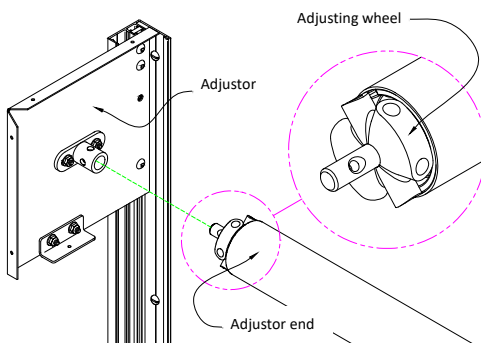


**Figure 2**

**Step 4:** Install brackets; refer to Figure 3. Two brackets are supplied with each unit, one adjuster and one operator. The operator bracket will have one of the following attached at the center: cast iron U-shaped lug with cotter pin (push-up), gearbox with extended eye (hand crank) or flange bearing (motor). The adjuster bracket will have a tubular cast iron lug mounted at center. The brackets are oriented such that the mounting holes line up with those in the bracket mounting flat, clip angle toward bottom and bent returns toward opening. Three 5/16-18 x 5/8” button head socket cap screws are used to attach brackets to bracket mounting flats as shown in Figure 3.



**Figure 3**



**Figure 4**

**Step 5:** Install shaft. Shaft installation will vary slightly based on operation of unit. Shaft installation for each type of operation will be described below. Common to all shafts, regardless of unit operation, is the adjuster. Each shaft has a circular cast iron adjusting wheel with six pockets for use when charging the springs; this end of the shaft will be referred to as the adjuster end of the shaft; refer to Figure 4. If unit is

## Section 7 – Installation Instructions

supplied with S114A rings, they must be placed on shaft prior to shaft installation. Lay shaft on ground in front of opening with adjuster end toward mounting member having adjuster bracket and weld studs on top. Slide rings onto shaft as illustrated in Figure 5, with “hump” of ring away from opening. **NOTE: Rings must be placed on shaft as shown in Figure 5 for curtain to roll properly.** Remove #10-24 x 5/8” truss head screws from weld studs, locate rings over weld studs and replace truss head screws. Do not tighten screws down, they must be removed for curtain attachment.

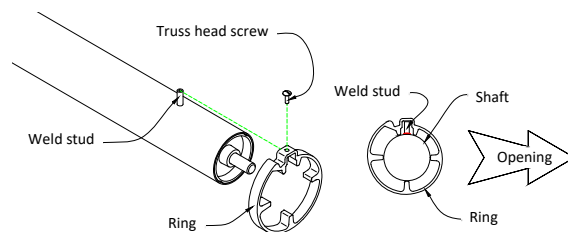


Figure 5

**Push-up:** Remove cotter pin from cast iron U-shaped lug on operator bracket. Raise shaft and hold just under brackets. Raise adjuster end further and line up with inside hole of tubular cast iron lug on adjuster bracket and insert as far as possible. Raise operator end of shaft up along inside of bracket, while at the same time pushing shaft toward adjuster bracket, and lay operator end in U-shaped lug. Replace cotter pin and bend slightly to retain in place.

**Hand crank:** Raise shaft and hold just under brackets. Raise operator end further and line up with inside hole of gearbox on operator bracket and insert as far as possible. Raise adjuster end of shaft up along inside of bracket, while at the same time pushing shaft toward operator bracket. Line up adjuster end of shaft with inside hole of tubular cast iron lug on adjuster bracket and slide shaft inside. Line up hole in operator end of shaft with that of gearbox and pin in place with 1/8 x 1” grooved pin. If there is not sufficient clearance to slide the operator end of shaft through gearbox and line up adjuster end with lug, it will be necessary to remove operator bracket from mounting member. Once operator bracket is removed, it is slid onto operator end of shaft. Raise shaft and bracket and line up adjuster end with inside hole of tubular cast iron lug on adjuster bracket and insert as far as possible. Line up hole in adjuster end of shaft with one in tubular cast iron lug and use 1/4-20 x 1-1/2” grade 8 hex bolt and nut to pin in place. Align mounting holes of operator bracket with those of the bracket mounting flat and reattach bracket. Remove hex bolt and nut, line up hole in operator end of shaft with that of gearbox and pin in place with 1/8 x 1” grooved pin. If there is still not enough clearance to install the shaft by removing the operator bracket, it will be necessary to also remove adjuster bracket from mounting member. Once adjuster bracket is removed, the tubular cast iron lug is slid over the adjuster end of shaft; line up hole in adjuster end of shaft with one in tubular cast iron lug and use 1/4-20 x 1-1/2” grade 8 hex bolt and nut to pin in place. Raise shaft and brackets, align mounting holes of brackets with those of the bracket mounting flats and reattach brackets. Remove hex bolt and nut, line up hole in operator end of shaft with that of gearbox and pin in place with 1/8 x 1” grooved pin.

**Motor:** Raise shaft and hold just under brackets. Raise operator end further and line up with bore of the bearing on operator bracket and insert as far as possible. Raise adjuster end of shaft up along inside of bracket, while at the same time pushing shaft toward operator bracket. Line up adjuster end of shaft with inside hole of tubular cast iron lug on adjuster bracket and slide shaft inside. If there is not sufficient clearance to slide the operator end of shaft through bearing and line up adjuster end with lug, it will be necessary to remove operator bracket from mounting member. Once operator bracket is removed, it is slid onto operator end of shaft. Raise shaft and bracket and line up adjuster end with inside hole of tubular cast iron lug on adjuster bracket and insert as far as possible. Line up hole in adjuster end of shaft with one in tubular cast iron lug and use 1/4-20 x 1-1/2” grade 8 hex bolt and nut to pin in place. Align mounting holes of operator bracket with those of the bracket mounting flat and reattach bracket. Remove hex bolt and nut. If there is still not enough clearance to install the shaft by removing the operator bracket, it will be necessary to also remove adjuster bracket from mounting member. Once adjuster bracket is removed, the tubular cast iron lug is slid over the adjuster end of shaft; line up hole in adjuster end of shaft with one in tubular cast iron lug and use 1/4-20 x 1-1/2” grade 8 hex bolt and nut to pin in place. Raise shaft and brackets, align mounting holes of brackets with those of the bracket mounting flats and reattach brackets. Remove hex bolt and nut.

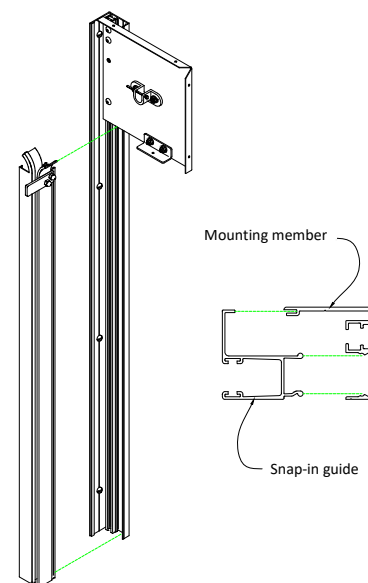
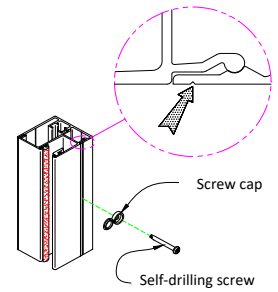


Figure 6

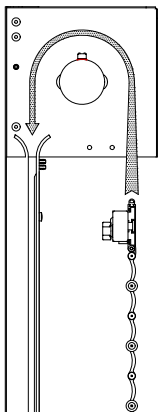
## Section 7 – Installation Instructions

**Step 6:** Install guide. Taking snap-in guide for left jamb, orient it in front of mounting member as illustrated in Figure 6. To “snap” the guide together on face of wall units, C-clamps with blocks of wood are used. Placing a block of wood on back of mounting member and gap of snap-in guide, slowly tighten down on C-clamp watching until outer face corners contact. Leaving that C-clamp in place, repeat the same process 12” +/- higher. Remove first clamp and repeat process 12” +/- higher and so on. For Between jamb units a block of wood is placed over guide gap and a hammer is used to “tap” snap-in guide in place. **CAUTION:** Using a hammer to install snap-in guide on a face of wall unit may loosen mounting member fasteners and is not advisable on smaller units. #8 x 1-1/2” self-drilling screws and screw caps are installed at all marks on mounting member groove; refer to Figure 7. This process is repeated with guide at right jamb.



**Figure 7**

**Step 7:** Install curtain. On smaller units, curtain attachment is by means of 1/4-20 x 3/8” pan head screws; retainer weld nuts are provided on shaft. As mentioned earlier, larger units will be supplied with S114A rings and #10-24 x 5/8” truss head screws; weld studs are provided on shaft. Follow the respective instructions below for curtains with openings of 65 ft<sup>2</sup> or less or for those with openings greater than 65 ft<sup>2</sup>.

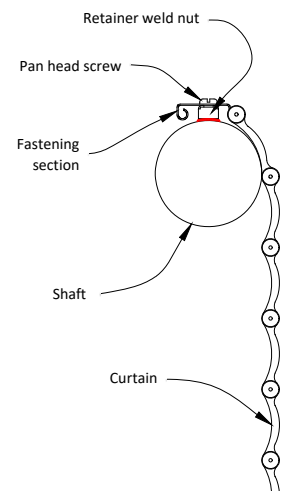


**Figure 8**

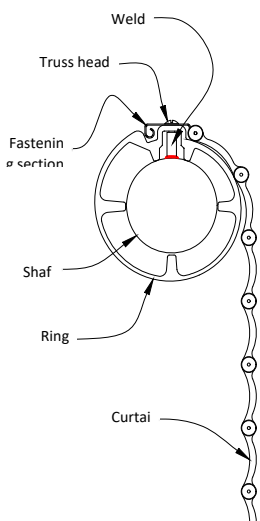
**Shafts with retainer weld nuts:** Remove stoppers from both guides and bottom clip angle from both brackets. Place curtain flat on ground between guides with exterior face up (arched side of molded links up). Pick curtain up by bottom bar, feed between brackets over shaft and then down between lintel and shaft into guides; refer to figure 8. Line up slots in fastening sections with retainer weld nuts on shaft. Install 1/4-20 x 3/8” pan head screws into retainer weld nuts; refer to Figure 9. Prior to tightening down screws be sure curtain is spaced evenly between mounting members. Replace stoppers and clip angles.

**Shafts with S114A rings:** Remove stoppers from both guides and bottom clip angle from both brackets. Remove #10-24 x 5/8” truss head screws from weld studs. Place curtain flat on ground between guides with exterior face up (arched side of molded links up). Pick curtain up by bottom bar, feed between brackets over shaft and then down between lintel and shaft into guides; refer to figure 8. Line up slots in fastening

sections with hole in rings and weld studs. Install truss head screws into weld studs; refer to Figure 10. Prior to tightening down screws be sure curtain is spaced evenly between mounting members. Replace stoppers and clip angles.



**Figure 9**

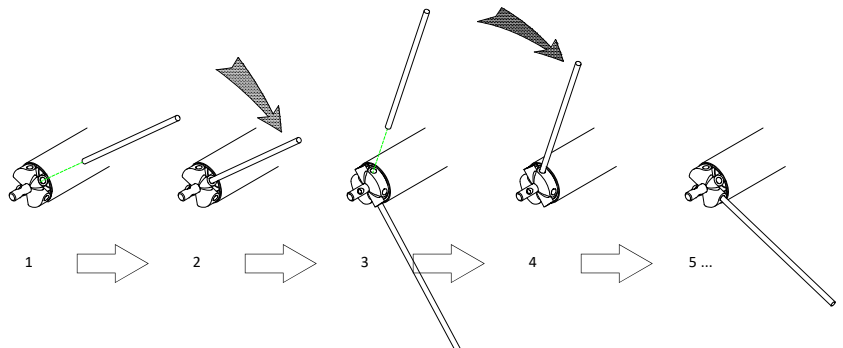


**Figure 10**

**Step 8:** Charging springs. **CAUTION:** Do not stand directly in front of adjusting wheel while charging springs; stand off to side on firm footing, severe injury can result should a rod slip during the spring charging process. Have 1/4-20 x 1-1/2” grade 8 hex bolt and nut readily available and two 3/8” diameter rods are needed. Number of turns will be labeled on shaft at adjustor side; this is how many turns springs must be wound with curtain. Springs are wound by turning adjusting wheel number of turns labeled on shaft. Using a marker, place a mark on edge of adjusting wheel where it is visible. Place one of the 3/8” rods in a pocket of adjusting wheel toward top, pull down toward floor. Insert second 3/8” rod in pocket near top, remove first rod and pull second rod down toward floor.

Continue this process while counting number of turns adjusting wheel makes; see Figure 11. **NOTE:** Adjusting wheel should always be wound in

direction of opening the curtain regardless of whether the unit is left hand or right hand adjust. As number of turns on adjusting wheel



**Figure 11**

### Section 7 – Installation Instructions

become greater, turning it will become harder and the curtain will have a tendency to lift up. Once proper number of turns have been added to adjusting wheel, continue to hold pressure on rod remaining in adjusting wheel and rotate it such that hole in shaft end aligns with top hole in tubular cast iron lug on adjustor bracket. Place 1/4-20 x 1-1/2" grade 8 hex bolt down through top hole of lug until head of bolt is sitting flush on lug (bolt should project through bottom of lug). The bracket may have to be pulled in or pushed out slightly to get bolt to drop through both lug and shaft. At this time pressure may be let off rod and it can be removed; install hex nut on bolt. Operate curtain up and down several times to check operation and readjust spring charge, if necessary, before installing hood.

**Step 9:** Install hood; refer to Figure 13. Place hood between brackets with end over lapping bracket returns and clip angles. Using #10 x 1/2" self-drilling screws attach hood to bracket returns and clip angles as necessary; refer to Figure 14.

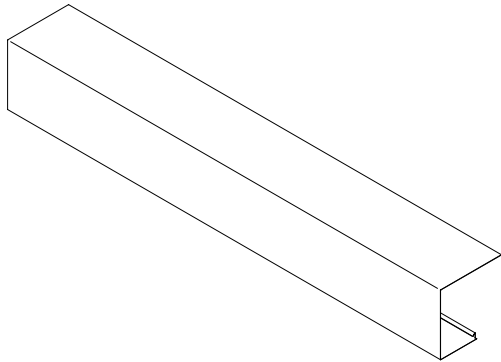


Figure 13

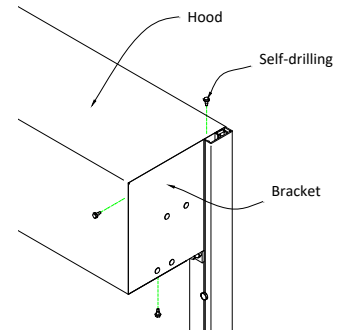


Figure 14