

Preferred door solutions.[®] COOKSON

Operation & Maintenance Manual

Products: Labeled Package Unit

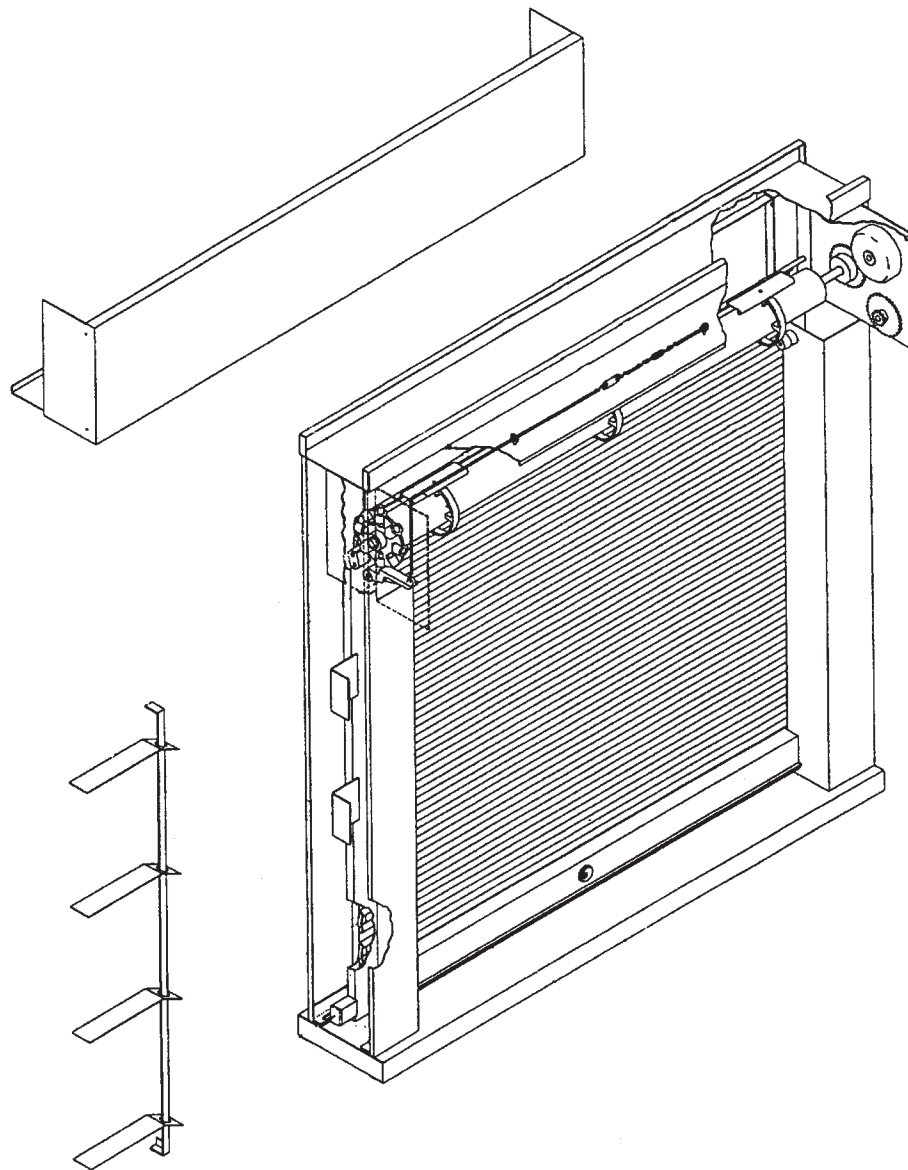

Preferred door solutions.[®]
COOKSON

For more information...
Contact the Service Department
Please Call 800-233-8366
Or Fax 800-526-0841

Crestwood Industrial Park, Mountaintop, PA 18707

PARTS LIST - LABELED PACKAGE UNIT

PUSH-UP, FACING COIL SIDE

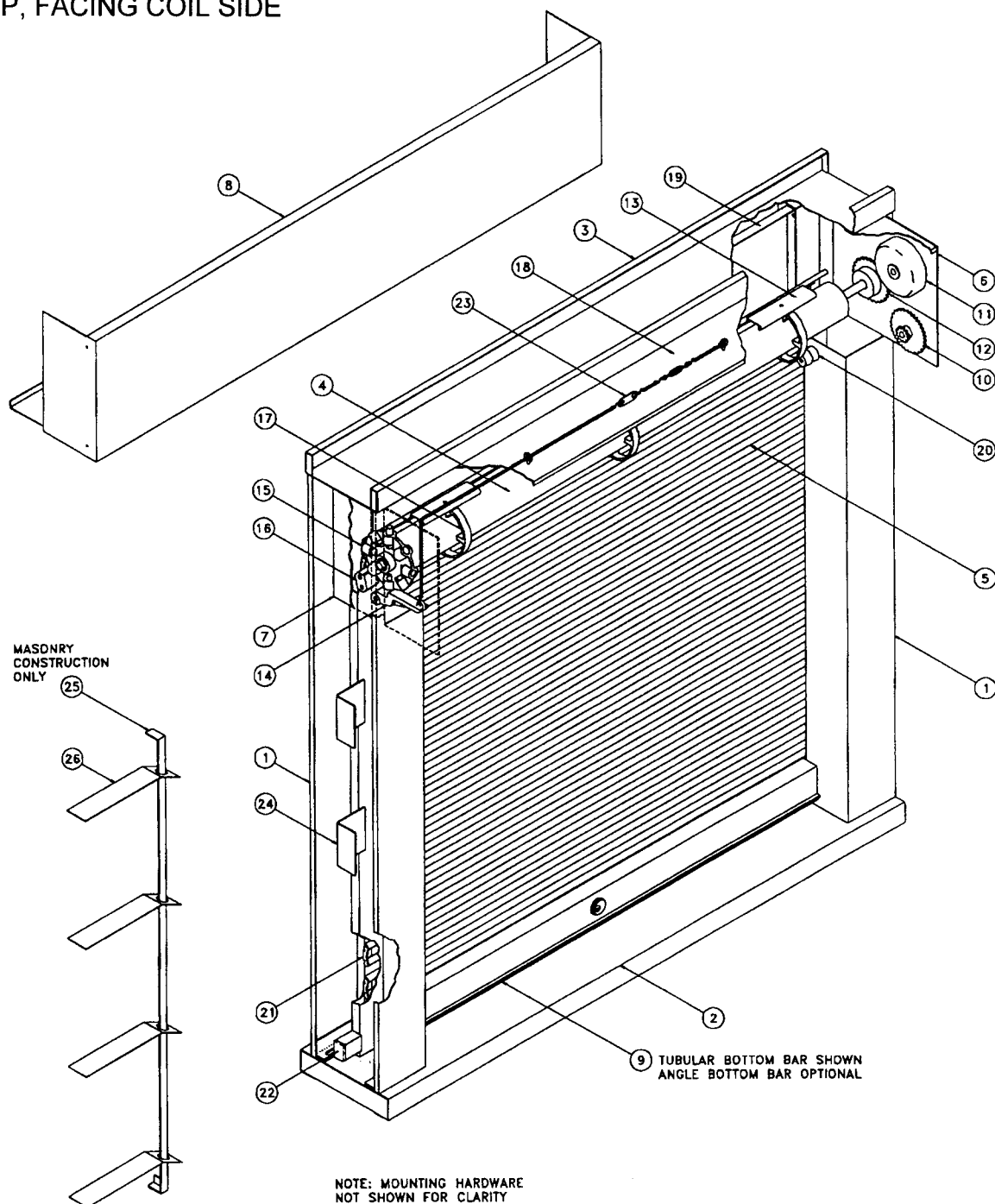

NOTE: MOUNTING HARDWARE NOT SHOWN FOR CLARITY

1	JAMBS	10	INTERMEDIATE SPROCKET	19	FASCIA
2	SILL ASSEMBLY	11	CLUTCH ASSEMBLY	20	RUBBER STOPPERS
3	HEAD ASSEMBLY	12	MAIN SPROCKET	21	ENDLOCKS (RIVETED TO SLATS)
4	BARREL (COUNTERBALANCE SHAFT)	13	FASTENING SECTION SLATS	22	PLASTER GUARDS
5	CURTAIN SLATS	14	DROPOUT PAWL	23	FUSELINK CHAIN ASSEMBLY
6	GOVERNOR BRACKET	15	ADJUSTING WHEEL WITH PIN	24	DRYWALL ANCHORS
7	ADJUSTOR BRACKET	16	STOP BLOCK	25	MASONRY MOUNTING ANGLE
8	HOOD	17	RINGS	26	MASONRY ANCHORS
9	BOTTOM BAR	18	TOP CLOSURE		

LABELED PACKAGE UNIT INSTALLATION INSTRUCTIONS

(Push-up, Facing Coil Side)

NOTE: This unit must be installed as wall is being built.

- STEP 1** Before beginning installation remove all packaging material from the unit and test the curtain to see that it operated properly. Check over entire unit to see that there is no damage and that unit is square. The unit may be tested at this time if desired for automatic closing by releasing the tension on the fusible link chain. **(Refer to the section below on Testing and Resetting.)**

NOTE: It will be necessary to remove the hood to reset the unit if it is tested.

- STEP 2** The wall or stud framing at this point should be built up the point where it is the proper height to support the unit at the underside of the sill. Compare this dimension against the dimension shown on the shop drawing to see that the two match. Next check this portion of the wall to see that it is level so unit will not have to be shimmed.

The unit may now be lifted into position at the opening and fastened in position as shown on the enclosed details.

NOTE: Do not lift unit at the center of the sill or coil area! Lift only by the side jambs to prevent damage.

- STEP 3** Once the unit is securely fastened into the wall construction it should again be tested for proper operation. Run the curtain up and down a few times to see that it operated smoothly without binding. The spring tension is pre-set at the factory and should not require further adjustment. When properly adjusted the curtain should stay down on the sill when closed, pull up slightly against the stop bumpers when open and be slightly heavy through the middle. The spring tension may be adjusted if desired by following the procedure outlined below for testing and resetting.

AUTOMATIC CLOSING & RESETTING INSTRUCTIONS

NOTE: The following procedure should be used for testing the unit for automatic closing and resetting the spring release mechanism.

WARNING: The spring adjusting wheel of this unit is under tension at all times and extreme caution should be used in testing and resetting this mechanism.

- STEP 1** To release the mechanism to test for automatic closing the turnbuckle in the fusible link chain can be opened and the chain let slack to drop out the spring release mechanism. To reset this mechanism the hood must be removed. This can be accomplished by removing the two screws in either end of the hood at the end closure plates and sliding the hood forward off the end brackets. This will expose the clutch governor mechanism at the right hand bracket and the spring release mechanism at the left hand bracket. To rewind the mechanism a set of 1/2 inch diameter winding bars approximately 12 inches will be required. To wind spring insert one of the bars in the uppermost hole in the adjusting wheel and pull downward. The second bar can then be inserted into another one of the holes toward the top of the wheel.

NOTE: Rewinding the tension will be easier if the unit is returned to the open position and propped or held in place.

- STEP 2** Continue winding the wheel until the pin in the wheel can be captured and held in place by raising the dropout arm. Reconnect the fusible link chain and the unit is now reset. The spring tension may be adjusted before reconnecting the fusible link chain by removing the holding pin from the tension wheel and repositioning it in a different hole to add or subtract spring tension. **(Refer to the detail sheet in these instructions for additional information).**

- STEP 3** The clutch mechanism may also be adjusted to speed up or slow down the rate of descent of the curtain by adjusting the shoe configuration in the clutch assembly. **(Refer to the detail sheet in these instructions for additional information).**

AUTOMATIC RELEASE MECHANISM FOR ADJUSTOR BRACKET

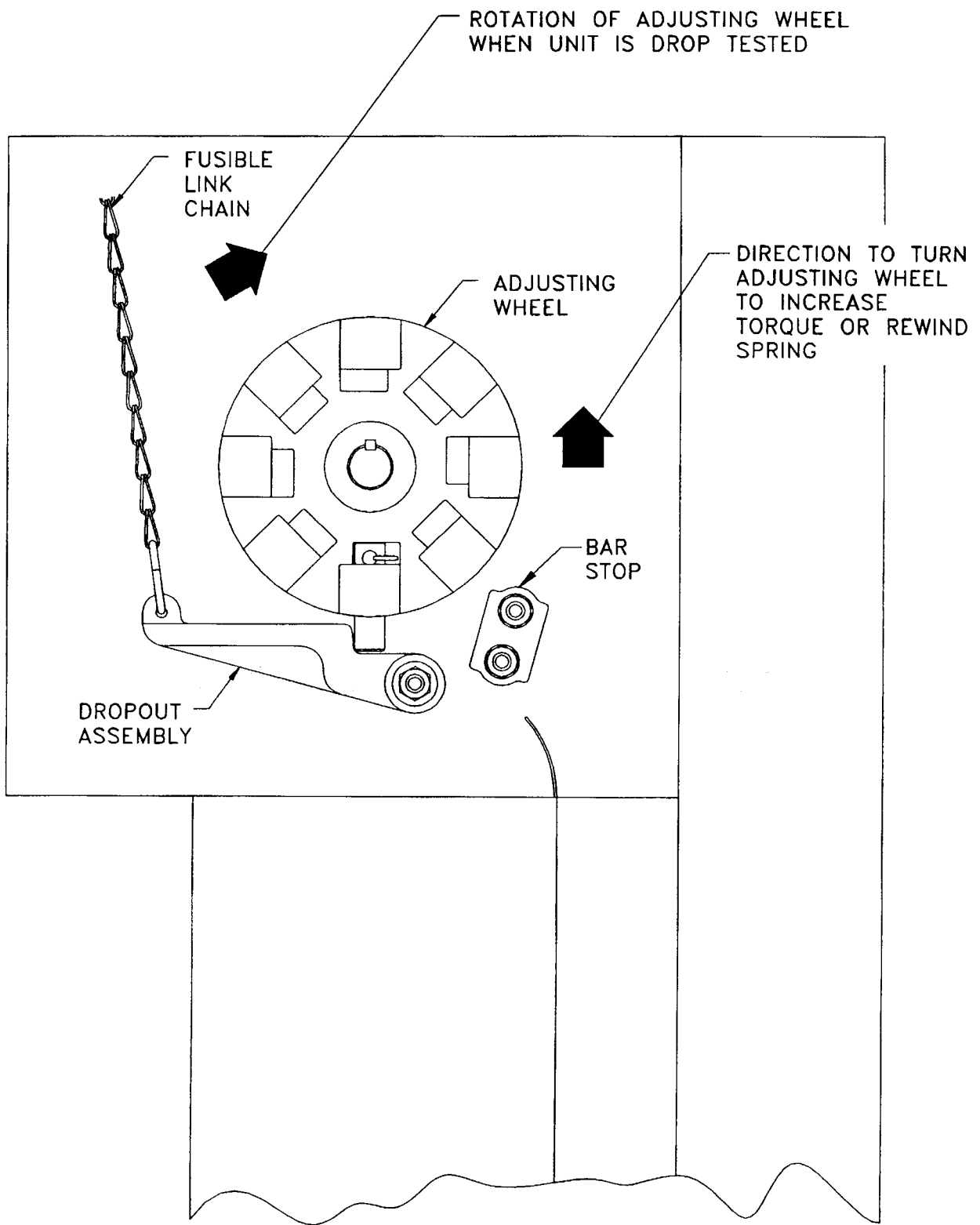

INSIDE VIEW OF L.H. ADJUSTOR BRACKET

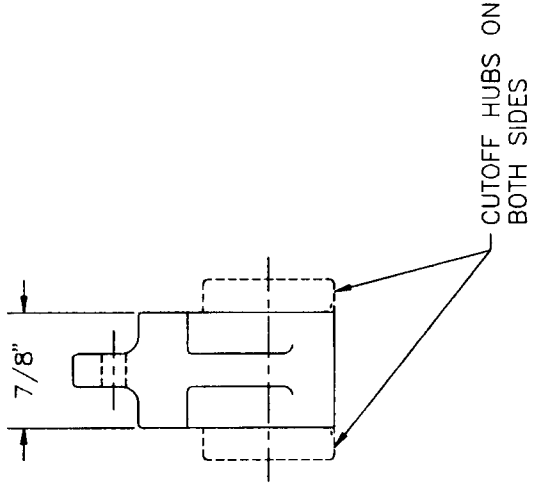
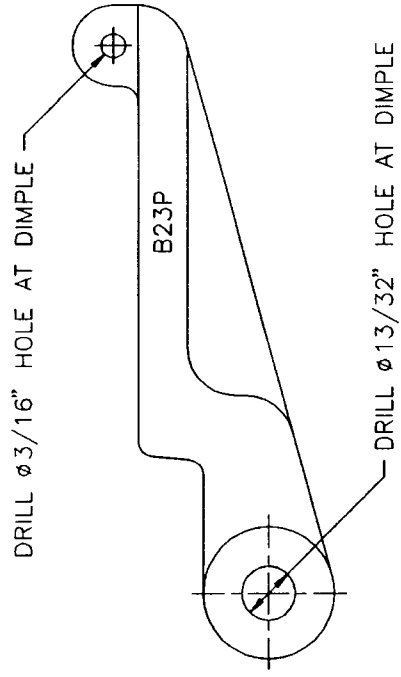

NOTES:
1. PART IS MADE FROM DROPOUT PAWL B23P.

DROPOUT PAWL

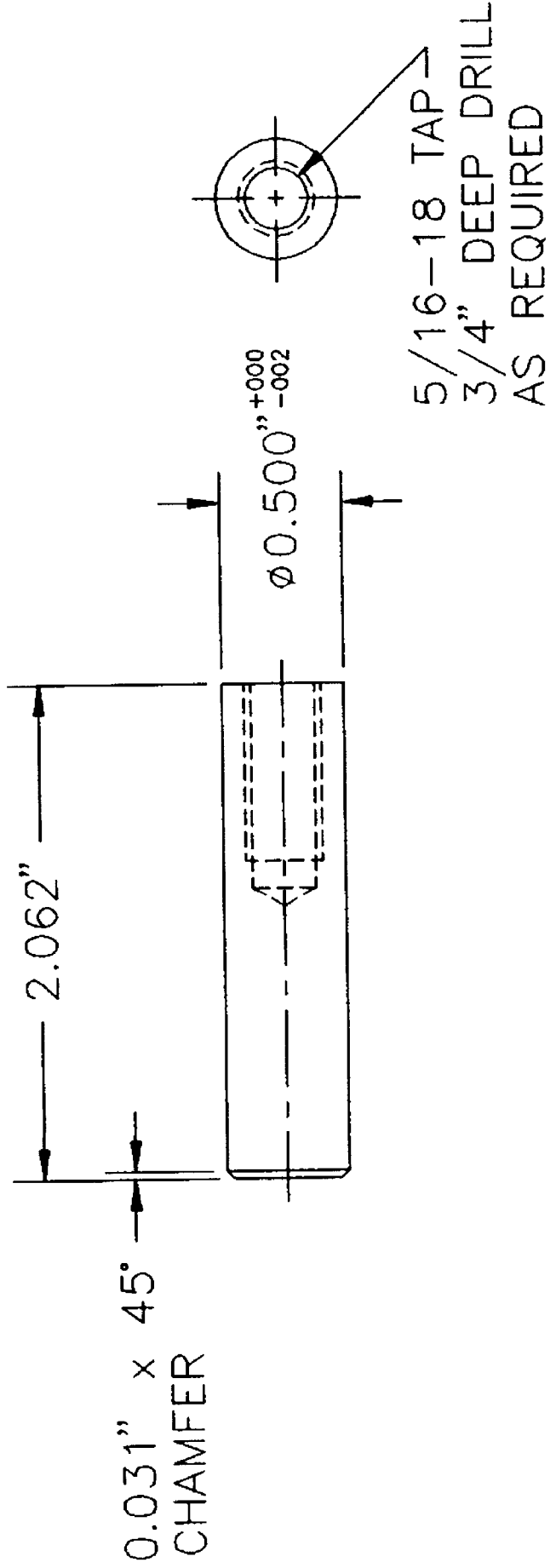

MATERIAL:
C1018 COLD FINISH STEEL ROUND

CLUTCH STUD