

# ***Installation Instructions, Visionaire MicroCoil Grille***

## Table of Contents





<b>Section 1 – Safety Check List</b>	<b>2</b>
<b>Section 2 –Freight Receiving</b>	<b>3</b>
<b>Section 3 – Pre-installation</b>	<b>4</b>
<b>Section 4 – Guides</b>	<b>5</b>
<b>Face of Wall Units Mounting to Wall</b>	<b>5</b>
<b>Face of Wall and Between Jamb Units Mounting to Free-Standing Tubes</b>	<b>6</b>
<b>Mixed Guides</b>	<b>11</b>
<b>Guide Stoppers</b>	<b>12</b>
<b>Section 5 – Barrel and Brackets</b>	<b>13</b>
<b>Preparation</b>	<b>13</b>
<b>Bracket Preparation</b>	<b>14</b>
<b>Hoisting and Installing Barrel Assembly</b>	<b>14</b>
<b>Section 6 - Motor Operator Installation</b>	<b>16</b>
<b>Applying Spring Turns</b>	<b>16</b>
<b>Section 7 – Hood Support Installation</b>	<b>18</b>
<b>Section 8 – Hood, Fascia, and Covers</b>	<b>19</b>
<b>Hood and Fascia</b>	<b>19</b>
<b>Covers</b>	<b>22</b>
<b>Section 9 – Torque Specifications</b>	<b>23</b>
<b>Section 10 – Maintenance Schedule</b>	<b>24</b>
<b>Section 11 – Curtain Repair</b>	<b>27</b>

## Section 1 - Safety Check List

Rolling doors are large, movable objects. They move with the help of electric motors or manual operators (chain, crank, push up, etc), and most have springs under high tension. These items and their components can cause injury. In order to avoid injury to yourself and others, please follow the instructions in this manual.

- Review the potential hazards and preventative measures listed below:

**Table 1.1 - Potential hazards and Preventative Measures**

Potential Hazard		Preventative Measure
	<b>⚠ DANGER</b>  <b>Pinned or crushed by closing door.</b>	<ul style="list-style-type: none"> <li>• Keep yourself and others clear of opening while door is in motion.</li> <li>• Do not allow children to play near or operate door.</li> <li>• Do not operate if door becomes jammed or broken.</li> </ul>
	<b>⚠ WARNING</b>  <b>Struck by adjusting wheel bar while applying spring turns.</b>	<ul style="list-style-type: none"> <li>• Be sure bar is adequate in strength and long enough to allow installer to apply the necessary torque.</li> <li>• Make sure bar is fully seated into the adjusting wheel slot before applying pressure.</li> <li>• Use two bars while applying turns to the adjusting wheel.</li> </ul>
	<b>⚠ WARNING</b>  <b>Electrical shock.</b>	<ul style="list-style-type: none"> <li>• Make sure electrical operator is properly grounded.</li> <li>• Turn off source power completely prior to servicing the motor.</li> <li>• Make sure wires are clear of any moving or potentially moving parts.</li> <li>• Avoid pinching wires when installing the motor cover.</li> </ul>
	<b>⚠ WARNING</b>  <b>Pinched by moving components.</b>	<ul style="list-style-type: none"> <li>• Make sure the motor is turned off and unplugged before working with moving parts such as roller chain and sprockets, drop-out mechanisms, adjusting wheels, etc.</li> <li>• Locate the possible pinch-points of the unit (Drive chain, coil area, bottom bar, etc.) Do not operate the door while someone is near these areas.</li> </ul>

- Check the following during installation and before leaving the job site:
  - a. If the unit has tension springs, be sure the proper amount of tension is applied to the torsion springs, in order to properly counterbalance the weight of the curtain.
  - b. Securely fasten the tension adjusting wheel in place with the appropriate hardware provided.
  - c. Check that the keys and/or cotter pins have been set in place and fit properly at all sprockets or gears.
  - d. Check that the setscrews in each sprocket or gear (one over the key and one offset from the key) have been tightened properly.
  - e. Check all fasteners holding the unit to the building structures.
  - f. Check all fasteners used to assemble the components of the unit together.
  - g. Instruct owner or representative in the proper method of operating the door.

## Section 2 – Freight Receiving

- **Upon delivery, check condition of components for damage.**
- **If damage occurred in transit, the installation should not proceed without authorization.**

### **NOTICE**

If the installation proceeds, neither the carrier nor the manufacturer will assume responsibility for replacing the damaged material.

- **If the installation is stopped due to damage, do the following:**
  1. Take pictures of the damage.
  2. Do not move material from point of delivery to other premises once the damaged components are discovered.
  3. Do not unpack, if the damage is visible prior to removing packaging, until an inspection is made.
  4. If the damage is found while removing contents from packaging, the packaging material must be saved until inspection is made.
  5. Container and packaging should be retained by consignee until inspection is made.
  6. Have components inspected by carrier's representative within 15 days from date of delivery.
  7. Consignee must obtain a copy of the Inspection Report.
- **Returning damaged components:**
  1. Obtain permission from carrier to return.
  2. Route the return shipment via the identical carrier(s) involved in the original shipment.
  3. Notify the manufacturer when shipment is returned to manufacture plant.
- **Verify that all components have arrived. Look for the following:**
  1. Job construction drawings featuring different views (elevation, section, plan, etc.)
  2. (2) Guide assemblies; check for guide weathering if included in order
  3. Packaged Barrel assembly, curtain assembly with bottom bar, and (2) Bracket assemblies.
  4. Operator; if not attached to bracket
  5. Operator cover; may not be included in order
  6. Adjusting wheel
  7. Hood and hood supports; may not be included in order
  8. Hardware
  9. Misc. items (Reelite, lintel seal, hood baffle, etc.)
  10. Verify material/finish/color of components matches what is listed on the job construction drawings and/or what was ordered.
- **If the delivery is incomplete:**
  1. Make note on delivery receipt.
  2. Note should be verified by driver's signature.
  3. Notify carrier and manufacturer.

### Section 3 – Pre-Installation

- **Read entire instruction manual thoroughly. The manufacturer will not be held responsible for any charges incurred due to improperly installed components.**
  - a. Only trained door systems technicians should perform installation, maintenance, etc.
  - b. Each unit comes with an individual item number. If the job contains multiple units, be sure to locate all the components for each item and separate each.

#### **⚠ WARNING**

**Do not** interchange parts from one door to another.

- c. Find the job construction drawings for the unit being installed and check the dimensions of the opening against those on the drawings. See **Figure 3.1** below.
- d. If the opening dimensions differ from those on the drawings, **do not proceed**, check with distributor/manufacturer to be sure the correct door is being installed.
- e. Check the jambs of the opening for plumb. Check the head/lintel and floor for level. If the unit is to be free standing, for example mounted to tubes, check the floor and ceiling for level and for adequate mounting areas at the top and bottom.

*Note: The floor may not be level if a pitched bottom bar is specified.*

- **Work Area:**
  - a. The key to a smooth installation is a clean and well-prepared work environment. Once the components have been inspected and the job construction drawings have been reviewed; lay out the components in the order of installation.
  - b. The opening for the door should be cleaned and inspected for rough surfaces and construction debris.
  - c. Lastly the mounting hardware supplied with the door should correspond with the surface and construction features of the opening.
  - d. The basic assembly sequence is as follows:
    1. Guides.
    2. Packaged Barrel, curtain with bottom bar and Bracket assembly.
    3. Motor operator (if applicable).
    4. Weather stripping (if applicable).
    5. Hood, and operator/adjustor/idler covers (if applicable).

**Figure 3.1 - Opening Dimensions and Designations**

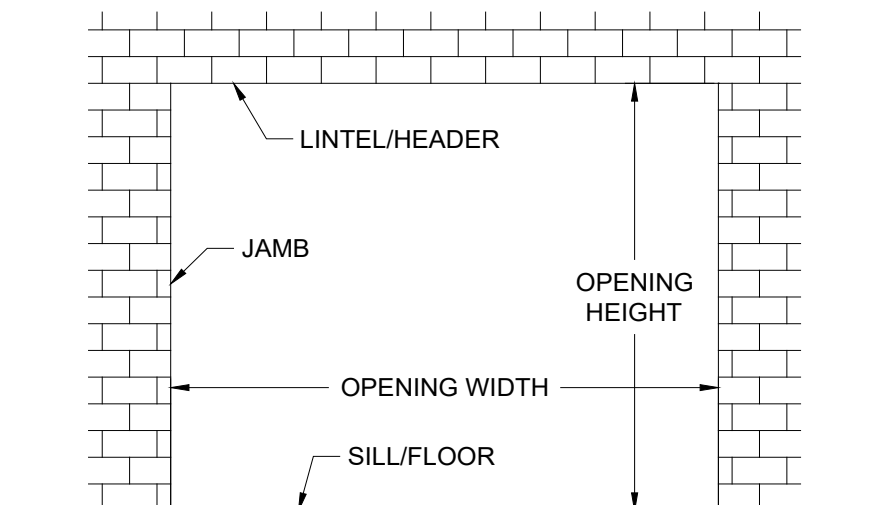

## Section 4 – Guides

### Face of Wall Units Mounting to Existing Wall Construction (Figures 4.1 - 4.2):

**Note:** Determine which guide assemblies are utilized on the unit from the job construction drawings and compare to the diagrams below.<sup>1</sup>

**Figure 4.1 – Face of Wall “E” Guide**

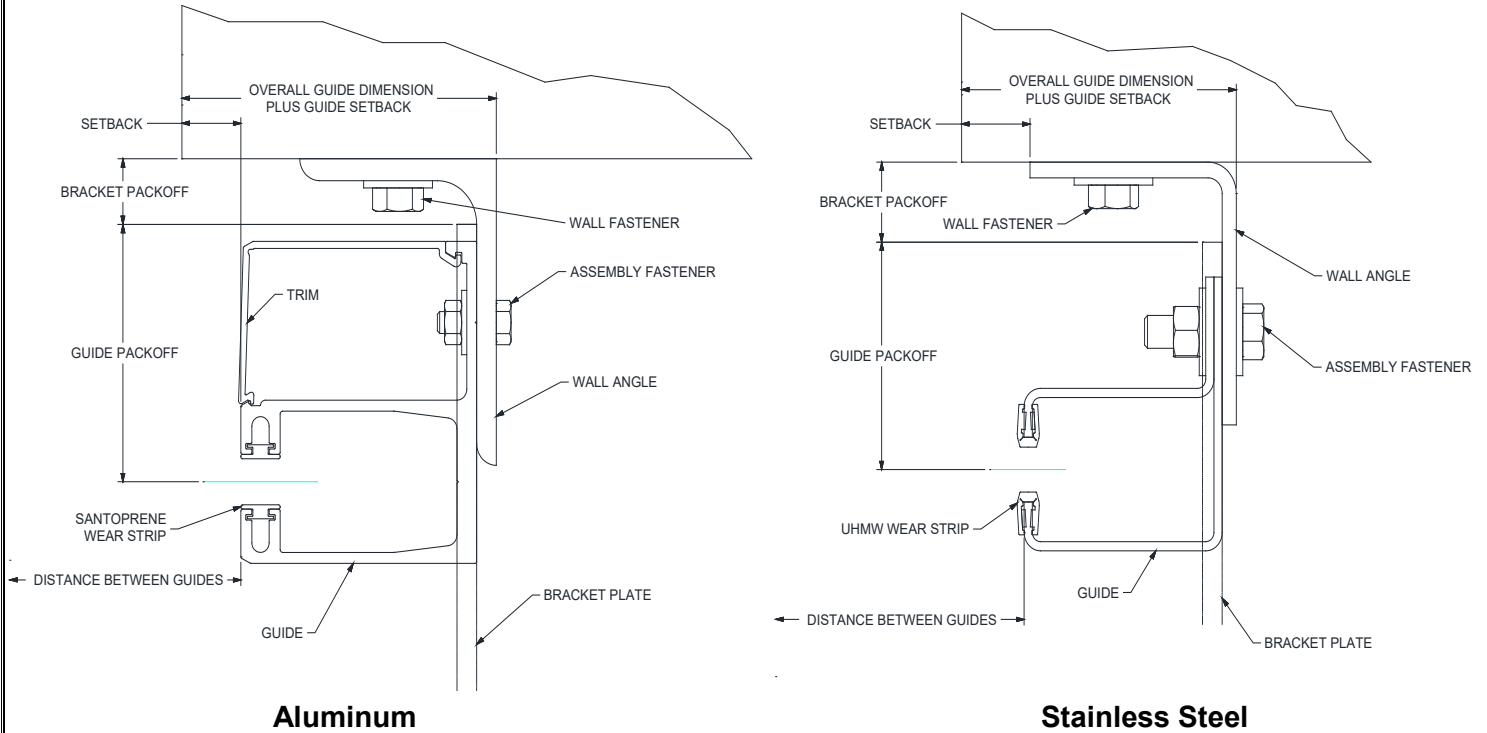

**Figure 4.2 – Face of Wall “Z” Guide**

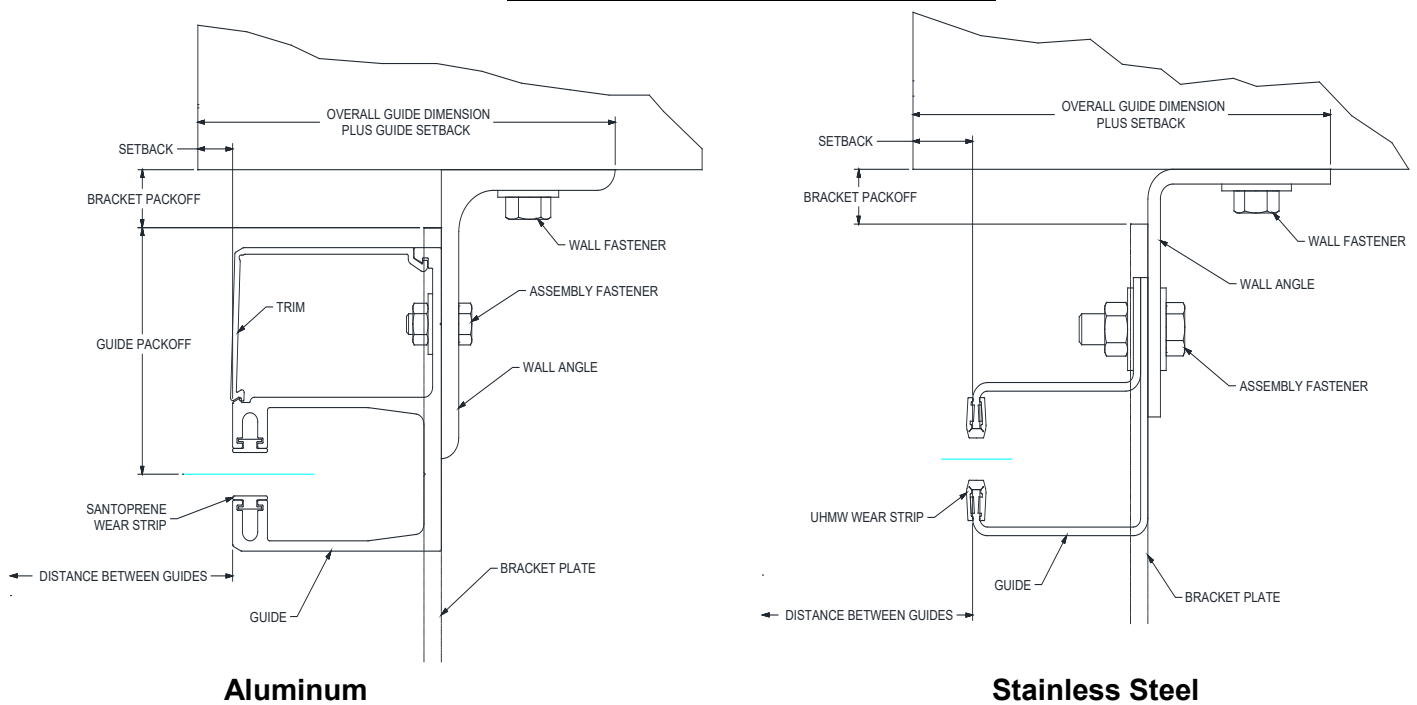

<sup>1</sup> The guide assembly may differ from the right to left hand side of the unit. In these cases, follow the directions for each particular guide assembly, as well as the job construction drawings provided with the unit.

## Section 4 – Guides

### Face of Wall and Between Jamb Units Mounting to Free-Standing Tubes (Figures 4.3 - 4.5):

**Note:** Determine which guide assemblies are utilized on the unit from the job construction drawings and compare to the diagrams below.<sup>1</sup>

**Figure 4.3 –Face of Wall “E” Guide Mounting to Tube**

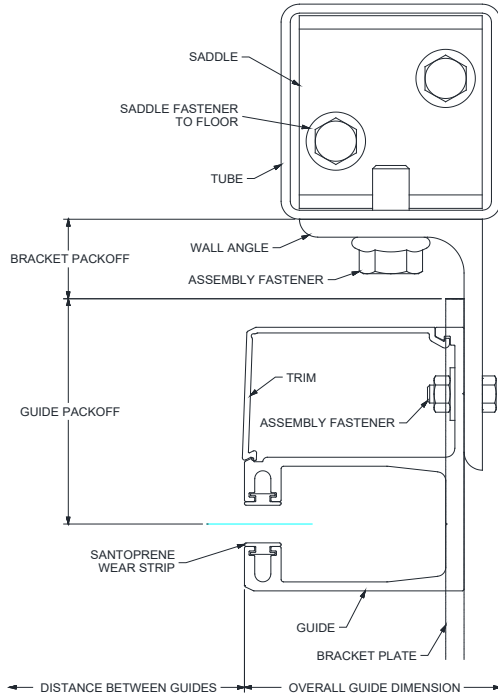

**Aluminum**

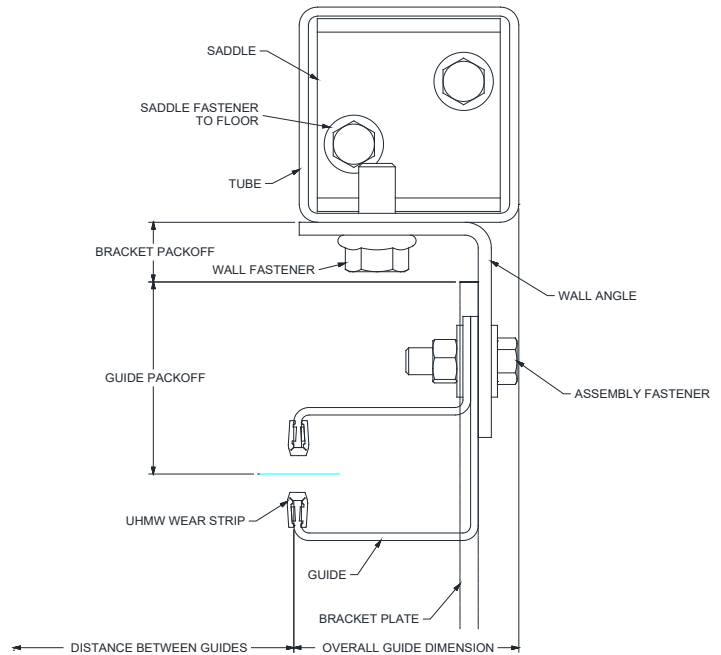

**Stainless Steel**

**Figure 4.4 –Face of Wall “Z” Guide Mounting to Tube**

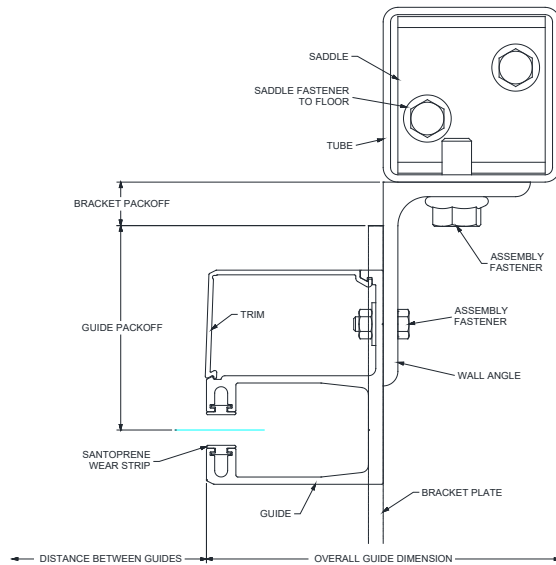

**Aluminum**

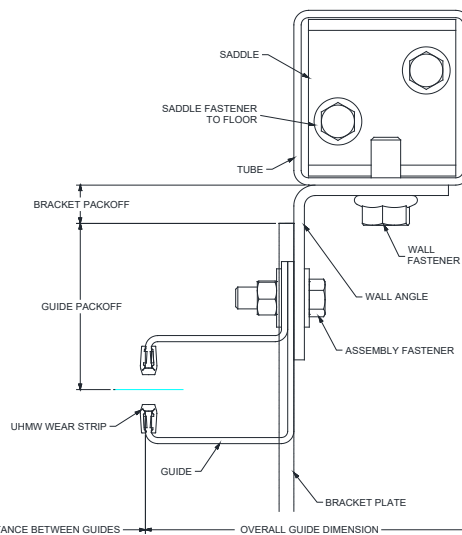

**Stainless Steel**

<sup>1</sup> The guide assembly may differ from the right to left hand side of the unit. In these cases, follow the directions for each particular guide assembly, as well as the job construction drawings provided with the unit.

## Section 4 – Guides

**Figure 4.5 – Between Jamb Mounting to Free Standing Tube**

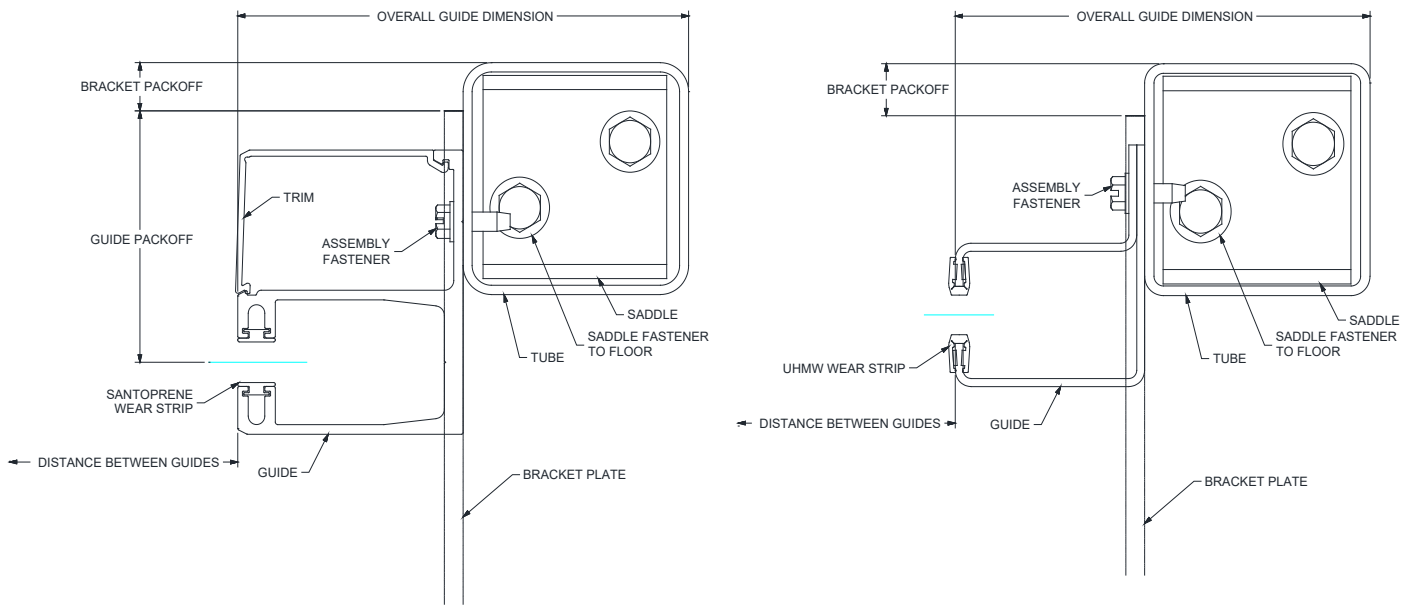

### Aluminum

### Stainless Steel

1. Separate the trim and guide from the wall angle if necessary for aluminum models. The aluminum trim can be unsnapped, out of the guide by pressing on location “A” (see **Figure 4.6**). To snap the trim into the guide, clip the longer leg into the guide, across the entire length (location “B”, **Figure 4.6**). Starting from the bottom, hold location “B” in place and exert force on the edge of the shorter leg, section “A”, until the trim snaps/clicks into the guide. Start snapping the trim from the bottom and progress upwards. On stainless steel guides, the stainless steel sensor cover can be disassembled, by removing the assembly bolts.

**Figure 4.6 – Trim Installation**

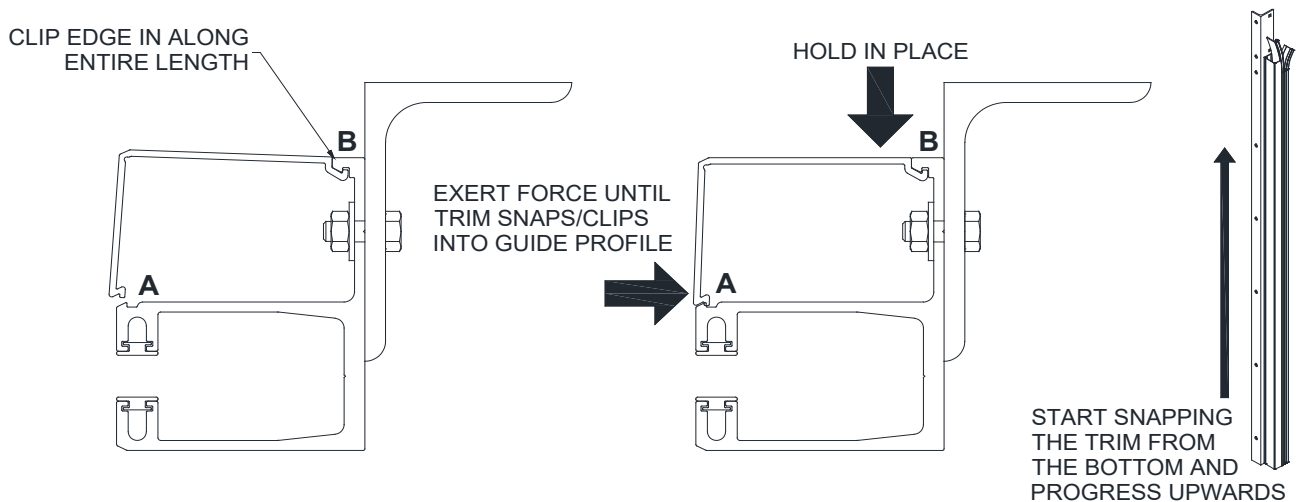

2. Measure the distance from the opening/jamb to the heel of the wall angle (on “E” guides) or the toe of the wall angle (on “Z” guides). This distance is referred to as the “Overall Guide Dimension plus Guide Setback”; see **Figures 4.1** and **4.2**. See the job construction drawings for the guide setback and overall guide dimensions.



## Section 4 – Guides

3. Place mark on the floor at measured location. Check the distance between these marks and compare with the job construction drawing. It will be the “*Opening Width*” plus the “*Overall Guide Dimension plus Guide Setback*” at both jambs.

### NOTICE

If the measurement does not equal the dimensions on the job construction drawings, **STOP**. Check the guide dimensions against those on the job construction drawings to be sure the correct guides are being installed. If so, repeat previous step and re-check.

4. Scribe a plumb line on the wall from the marks on the floor.
5. Place the wall angle against the scribed line, check the top of the guide for level, and mark the location of the wall fastener mounting holes.
6. If the wall angle is attached to the wall with fasteners, drill mounting holes for the wall fasteners and fasten the wall angle with the hardware provided. Check the job construction drawings for the required wall fastener. Tighten the wall fasteners to the recommended installation torque in the *Torque Specifications Tables* in **Section 9**.
7. If the guide is attached to the wall by welding to structural steel, see the job construction drawings for details on weld location, type, pitch, size, etc.<sup>1</sup>
8. At this point, the aluminum guide extrusion can be reassembled to the wall angle using the hardware provided. It is not necessary to snap the trim into place at this time. Tighten to the recommended installation torque in the *Torque Specifications* tables in **Section 9**.

**Note:** *You may find that delaying the installation of the aluminum guide extrusions until after the curtain is installed may alleviate the curtain installation process. This is a matter of preference, and will not affect the final product. If this is the case, set the guide extrusions, trim pieces and hardware aside until after the curtain is installed.*

1. Separate the trim pieces, aluminum guide, structural tubes (and wall angles) if required.
2. Refer to the job construction drawings to determine the specified mounting tube location. Measure and mark the location of the mounting tubes.
3. Check the distance between these marks and compare with the job construction drawing. It will be the “*Opening Width*” plus the “*Overall Guide Dimension*” at both jambs.

### NOTICE

If the measurement does not equal the dimensions on the job construction drawings, **STOP**. Check the guide dimensions against those on the job construction drawings to be sure the correct guides are being installed. If so, repeat previous step and re-check.

4. *Tube Saddles* are provided for installing free-standing tubes. Locate the tube saddles (brackets used to constrain the tube at the bottom). There are two types of saddles: *standard saddles* and *inverted saddles*. Both utilize the same steps for installation. The difference is the mounting flange.

**Note:** *If bottom bar locking is provided, be sure to orient the saddles as not to interfere with the throw of the slide bolt. See **Figure 4.8**.*

---

<sup>1</sup> Minimum recommended weld rod: AWS A5.1, Grade E-70.

## Section 4 – Guides

**Figure 4.7 – Tube Saddles**

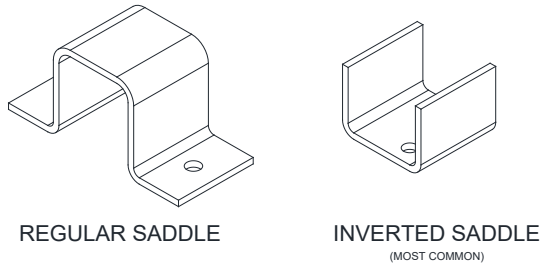

**Figure 4.8 – Tube Saddle Hole Location**

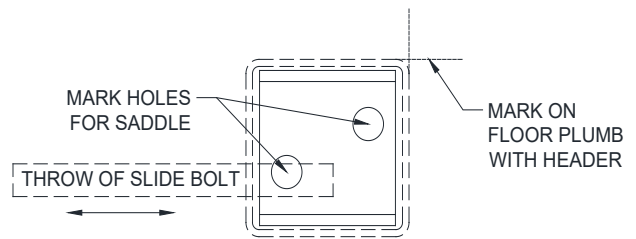

5. Use the mark placed on the floor in the previous steps, to locate where the saddle will be and mark the hole locations by placing the saddle on the floor. See **Figure 4.8**.
6. Double check the width dimensions provided on the job construction drawings, then drill holes for the saddle fasteners.
7. Install saddles using the provided hardware.
8. Guides mounting to tubes, sometimes require the use of a slip joint. Locate the Slip Joint Mounting Member(s).

**Note:** If the unit does not have slip joints and the top mounting for the tube is not provided by the manufacturer, install as recommended by supplier, then proceed to **Step 13**.

9. Use the job information and the marks made in the previous steps to determine the correct Slip Joint Mounting Member location. Install using the provided hardware. Use only enough fasteners to hold the Mounting Members securely in place (2), as they will be removed in a later step.
10. Determine the required tube length. Refer to **Figure 4.10**.
  - a. Measure from the “Floor to Slip Joint Mounting Member” as shown in the corresponding **Figure 4.9** below. Record this measurement.
  - b. To allow for expansion, the steel tube will need to be cut short. To determine the required “Expansion Allowance”, round the measurement taken in the previous step **up** to the nearest foot increment. Multiply the rounded value by 1/8 in/ft. Refer to the table below for examples:

**Table 4.9 – Slip Joint Expansion Allowances**

Floor to slip joint mounting member (ft)	9	10	11	12	13	14	15	16	17	18	19	20
Expansion Allowance (in)	1 1/8	1 1/4	1 3/8	1 1/2	1 5/8	1 3/4	1 7/8	2	2 1/8	2 1/4	2 3/8	2 1/2

- c. Calculate the Tube Length:  
 $Tube\ Length = \text{“Floor to Slip Joint Mounting Member”} - \text{“Expansion Allowance”}$
  - d. Cut the tubes to the calculated “Tube Length”. Make sure you cut the excess tubing from the top. Otherwise you will cut off necessary mounting holes and/or notches.

**Note:** If regular saddles are provided, the tube length will have to be adjusted because the tube will not sit on the saddle flanges instead of the floor. Subtract the thickness of the flanges from the tube length.

11. Remove the Slip Joint Mounting Member(s). Place the Slip Joint Mounting Members in the tops of the tubes.

## Section 4 – Guides

12. Orient the tubes (ensure the guides, mounting holes or notches are facing the correct direction.) Place the bottom of the tube over the saddle. Stand the tube upright and reattach the slip joint mounting member using the previously drilled/marked holes to locate. Use all provided fasteners at this stage. Check that installed tube is plumb.

***Figure 4.10 – Slip Joint - Between Floor and Ceiling Mounting Assembly***

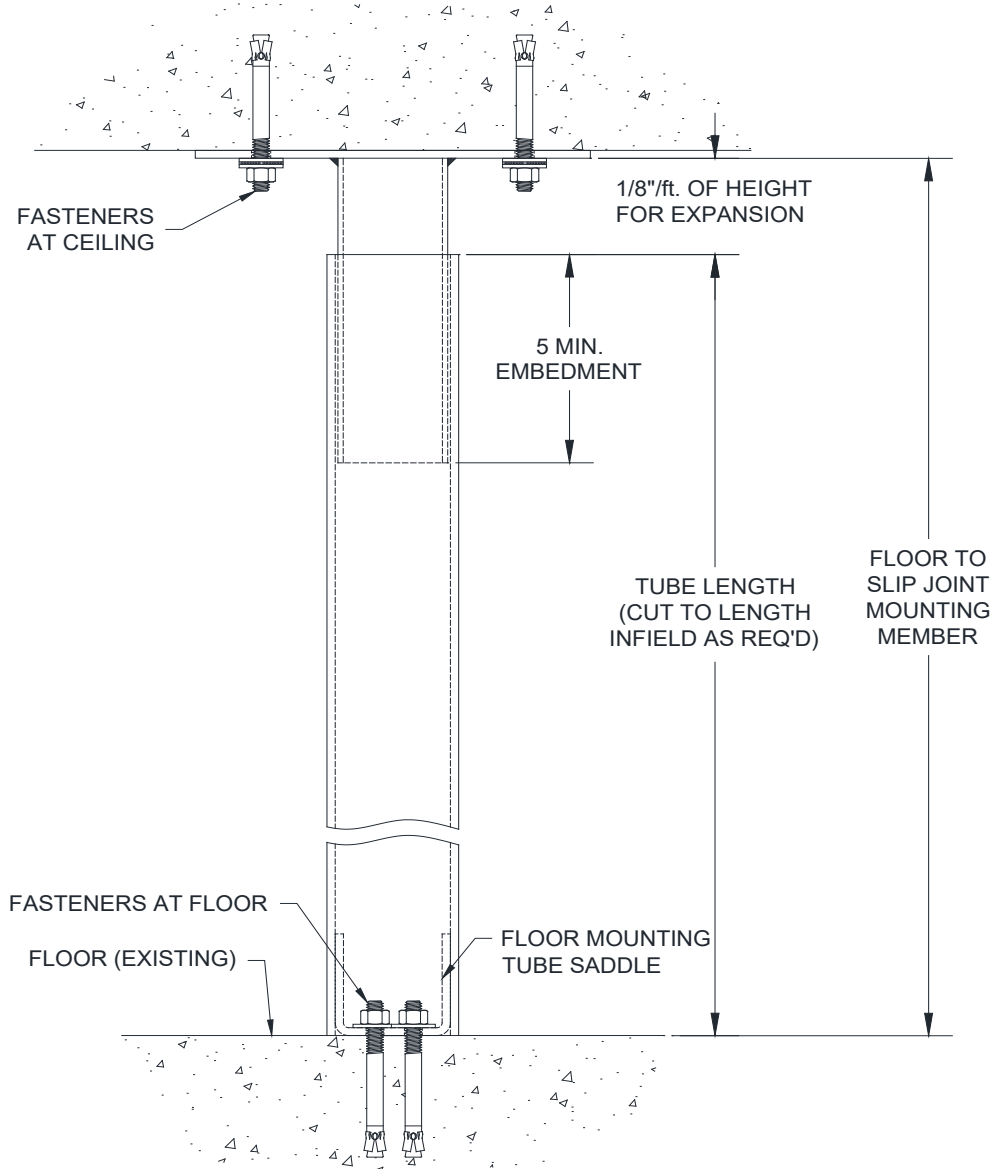

13. If the guide has a wall angle, as in **Figures 4.3 and 4.4**, fasten the wall angle to the mounting tube with the hardware provided. Check the job construction drawings for the required wall fastener. Tighten the wall fasteners to the recommended installation torque in the *Torque Specifications Tables* in **Section 9**.
14. At this point, the aluminum guide extrusion can be reassembled to the wall angle (or tube) using the hardware provided. It is not necessary to snap the trim into place at this time. Tighten to the recommended installation torque in the *Torque Specifications* tables in **Section 9**.

**Note:** You may find that delaying the installation of the aluminum guide extrusions until after the curtain is installed may alleviate the curtain installation process. This is a matter of preference, and will not affect the final product. If this is the case, set the guide extrusions, trim pieces and hardware aside until after the curtain is installed.

## Section 4 – Guides

1. Separate the trim pieces and aluminum guide extrusion from the flat or structural tubes if required.
2. Refer to the job construction drawings to determine the correct mounting location for the guide assemblies. Measure and mark the mounting locations on the floor.
3. Check the distance between these marks and compare with the job construction drawing. It will be the “Opening Width” plus the “Overall Guide Dimension” at both jambs.

### NOTICE

If the measurement does not equal the dimensions on the job construction drawings, **STOP**. Check the guide dimensions against those on the job construction drawings to be sure the correct guides are being installed. If so, repeat previous step and re-check.

4. Using the markings made in the previous step, position the flat/tube in the correct mounting position. Making sure the flat/tube is plumb, mark the mounting hole locations on the jamb wall using the flat /tube as a template. It may be beneficial to also score a line along the edge(s) of the flat/tube in order to realign it later.
5. Remove the flat/tube and prep the mounting holes as required.
6. Align the mounting holes in the aluminum guide extrusion and flat/tube with the prepped holes in the jamb wall.
7. Fasten the guide extrusion and flat/tube to the wall with the hardware provided. Check the job construction drawings for the required wall fastener. Tighten the wall fasteners to the recommended installation torque in the *Torque Specifications Tables* in **Section 9**. It is not necessary to snap the trim into place at this time.

**Note:** Other mounting styles offer you the choice of waiting until after the curtain is installed to install the aluminum guide extrusions. This option is not available for *Between Jamb Units Mounting to Wall*.

- **Mixed Guides (One Face of Wall and One Between Jambs):**

1. Refer to the job construction drawings for specific mounting information.
2. Follow the steps in the preceding sections for each of the respective guide configurations.
3. Ensure that the guide centers (centerline of the guide openings) are aligned before proceeding.

## Section 4 – Guides

### Guide Stoppers (Figures 4.11 - 4.12):

1. Install guide stops after curtain is in the guides.
2. Using a 5/32 hex allen wrench and thread lock, install the stopper into the aluminum guides as seen in **Figure 4.11**. with the provided 2X 10-32 x 3/4 socket head screws. The slotted hole in the stopper is fastened to the upper hole.

**Figure 4.11 – Aluminum Guide Stop Install**

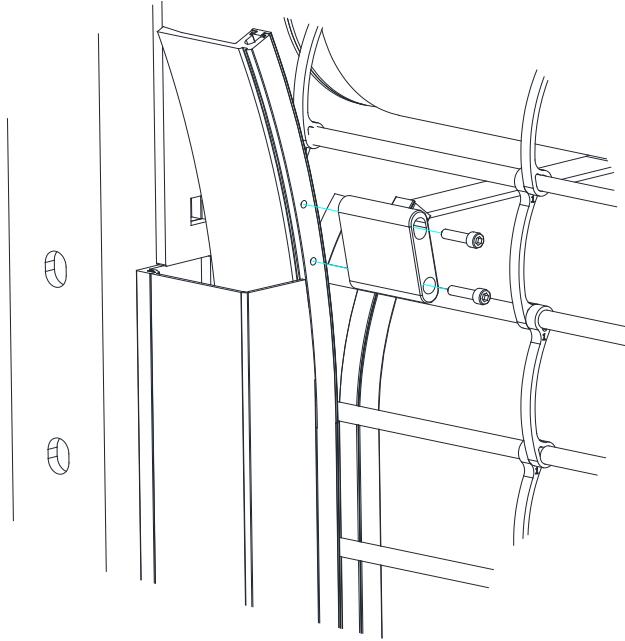

3. For stainless steel guides, place stopper with joggle facing away from the curtain and secure using the provided 2X 1/4-20 acorn nuts as seen in **Figure 4.12**.

**Figure 4.12 – Stainless Steel Guide Stop Install**

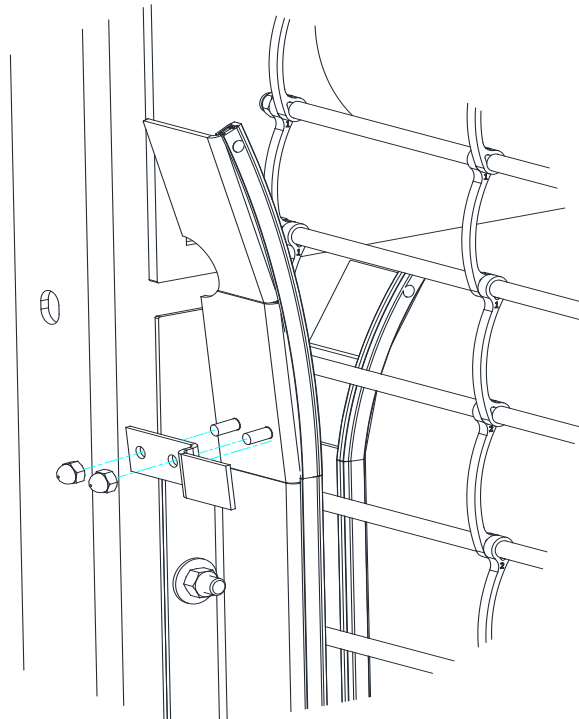

## Section 5 – Barrel and Brackets

### Preparation of the Barrel and Brackets

**Note:** Check to see if a hood support will be required. If so, refer to the “**Hood Support Installation**” section before proceeding to the barrel and brackets.

1. Refer to the job construction drawings to determine the “coil side” of the opening, or the side of the opening on which the coil is to be installed. Then determine which jamb wall is your “operator side”, or side on which the operator is to be installed. The following instructions refer to these directional cues.

**Note:** Units without operators (such as push-up units) are still considered to have an “operator” side. The shaft and job drawings will be marked with “operator” side regardless of the operation of the door so that it can be used as a directional cue.

2. Unpack the barrel assembly. Note the markings on the barrel, see **Figure 5.1** below.

**Figure 5.1 – Barrel Markings (left hand adjust shown)**

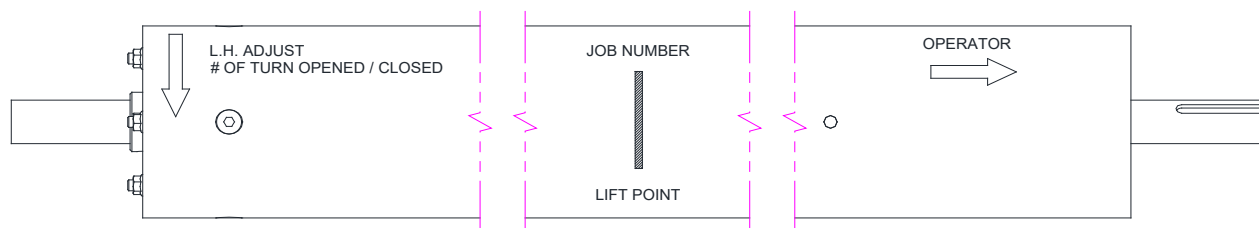

3. Position the barrel assembly on the coil side of the opening, with the end marked “operator” towards the “operator side” of the opening. In order to alleviate the ring and bracket installation, place the barrel assembly on blocks or spacers such that it is elevated off the ground.

**Note:** Choose sufficiently sized blocks. The barrel assembly should be elevated off the ground enough that the brackets can be installed without contacting the floor.

4. Check to make sure the required number of turns is noted on the barrel, as shown in **Figure 5.1**. Consult the distributor or the manufacturer if you cannot locate this information. Check that these numbers match the information provided on the job information. Take note of these numbers, as access to this information may be obstructed once the curtain is installed.
5. Typically the adjusting wheel is not shipped attached to the barrel. However, if the adjusting wheel *is* attached to the barrel, remove by loosening the bolt or set screws that secure the adjusting wheel to the barrel and sliding the wheel off the inner shaft. See **Figure 5.2**.

**Figure 5.2 – Removal of Adjustor Wheel from Barrel Assembly**

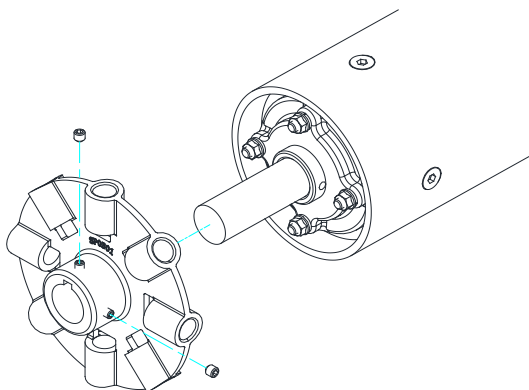

## Section 5 – Barrel and Brackets

**Figure 5.2.1 – Barrel Spacer Installation**

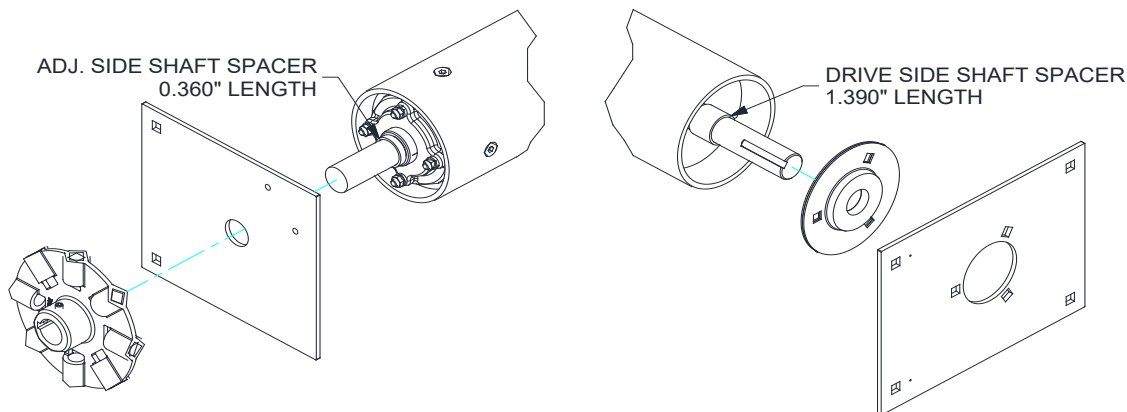

**Note:** Spacers provided on the shaft, make sure the correct spacer is on the drive side and adjuster side as seen above in **Figure 5.2.1**. **Spacers are required to prevent the barrel from shifting.**

6. Locate the brackets. Determine the “operator” and “adjustor” brackets by referring to **Figure 5.3**. The “operator” bracket may vary significantly based on the operation of the door. The “adjustor” bracket will contain a label with spring adjustment instructions.
7. Remove the adjusting wheel if you haven’t previously, and slide the adjustor bracket over the inner shaft of the barrel assembly. Install the adjusting wheel (see **Figure 5.2**).
8. Slide the operator bracket over the gear end until the inside face of the bracket is approximately 3 inches from the edge of the outer shaft. Do not tighten the set screws at this point, as you may need to adjust the position of the bracket. You may choose to install the drive sprocket (if present) at this point.

**Note:** Do not install the operator until the barrel and bracket assembly is hoisted into position and securely fastened to the guides. Installing the operator at this stage will cause the assembly to be lopsided and cumbersome, making it difficult and potentially dangerous to hoist into position.

**Figure 5.3 – Brackets and Barrel Prior to Installation**

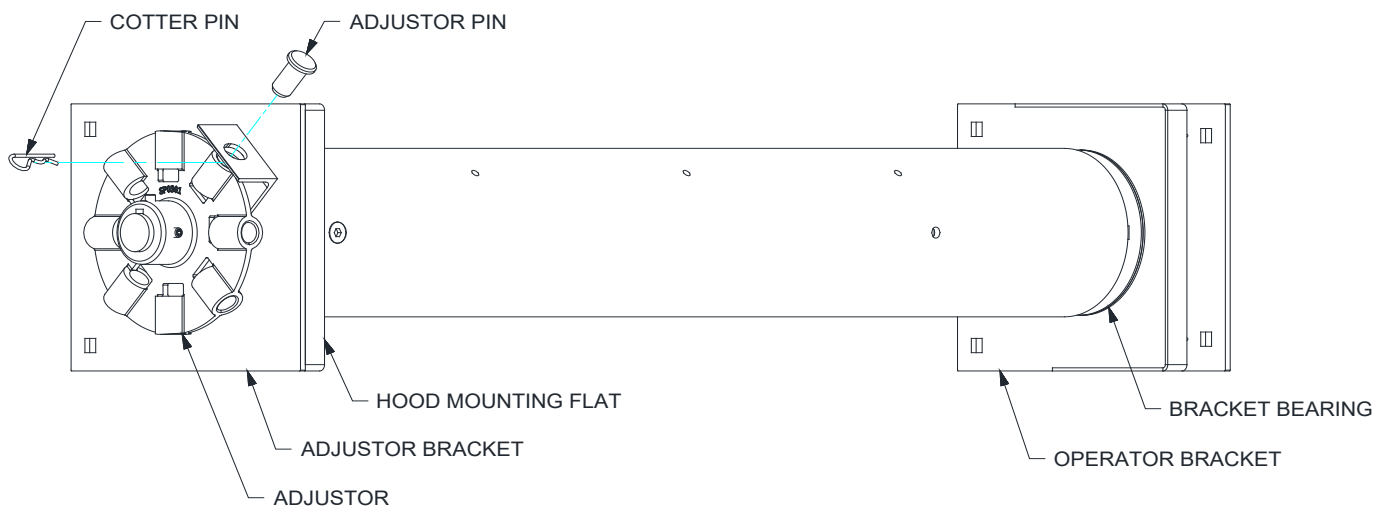

### ▪ Hoisting and Installing Barrel Assembly

1. The following methods can be used for hoisting them into place:
  - **Crane Hoisting:** Place a sling or lifting agent under the barrel assembly at the “lift point” provided on the barrel, see **Figure 5.1**.
  - **Forklift Hoisting:** Space the forks evenly under the “lift point” provided on the barrel, see **Figure 5.1**. Ensure that the barrel assembly is positioned close enough to the tips of the forks that the fastening

## Section 5 – Barrel and Brackets

holes in the bracket can be aligned with those of the guides without the forks contacting the wall. Secure the barrel assembly to avoid the slipping off the tip of the forks.

### **WARNING**

The addition of brackets may offset the balance slightly from when the “lift point” was marked. Check to make sure the assembly is properly balanced before hoisting.

2. Before hoisting, refer to the hardware sheet and ensure that the proper type and quantity of fasteners were provided for the bracket installation. Measure the distance between the brackets and compare that to your wall angles (*or between mounting angles if tubes are present*). Readjust the brackets as needed before hoisting.
3. Center the barrel assembly between the guides, keeping approximately 2 feet of clearance between the barrel assembly and wall/guides.
4. Raise the barrel assembly up to the approximate bracket mounting level. The brackets should be clear of the outer and inner guide angles.

**Note:** Position the brackets in the upright position, with the mounting holes facing the wall, before moving the assembly towards the wall. It may be difficult to rotate the bracket when in close to the wall.

5. Slowly maneuver the barrel assembly towards the guide, and align the mounting holes of the brackets with those of the wall angles (*or mounting angles if tubes are present*).
6. Insert the specified bolts and snug tighten, see **Figure 5.4**.

**Figure 5.4 – Bracket Mounting Configurations and Hardware**

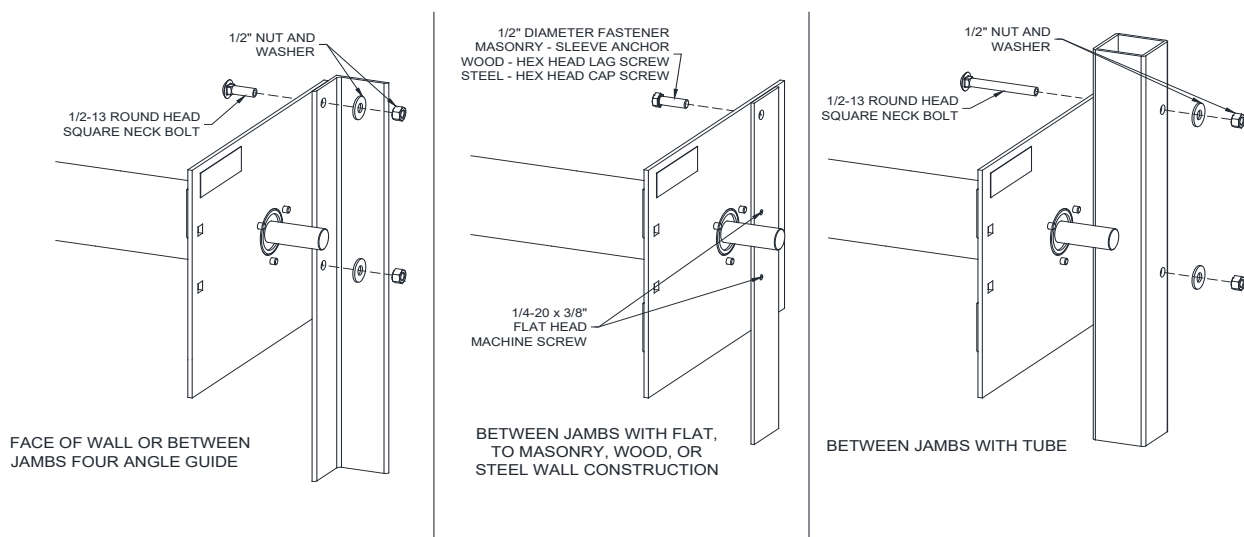

7. Check to see that the barrel is positioned properly between the brackets. That is, so that the proper amount of space is allowed between the barrel and the brackets. Typically the space is equal at both the operator and adjustor side. Adjust as necessary.
8. Place a level in the center of the barrel. If the shaft is **not** level:
  - Check the dimensions of the brackets from the top of the bracket to the center of the barrel.
  - Verify that the bracket mounting fasteners are the same distance from the top of the bracket.
    - a. If the dimensions **are not** correct, contact the Service Department.
    - b. If the dimensions **are** correct, the floor may be out of level, causing the bracket mounting holes in the guides to be out of alignment.
9. Fully tighten mounting bolts to the torque specifications in this manual. See *Torque Specification Tables* in **Section 11**.

### **NOTICE**

Proper pretension of the bracket mounting bolts will benefit the life of the bolts and brackets.

10. If the adjusting wheel was not previously installed, install it now. Do not install the adjustor pin yet.



## Section 6 – Motor Operator Installation

### Motor Operator Installation (if required):

1. Unpack the motor operator from the shipping box and retrieve the *Operator Mounting Bracket* and bolts provided in the kit.
2. There are several motor mounting configurations that can be formed with the supplied components. Refer to the shop drawings and components supplied with the kit in order to identify the specific style of mounting ordered for the unit. Some of the types of mounting are:
  - Vertical Bracket
  - Vertical Bracket Mounting With Tight Headroom
  - Wall Mounting
  - Horizontal Top of Coil
  - Horizontal Front of Coil
  - Horizontal Upside Down Front of Coil
  - Vertical Tube Mounting
  - Vertical Tube Top of Coil
3. If an operator cover is supplied, refer to the included Operator Cover Installation Instructions to assemble the cover mounting plate with the operator mounting bracket.
4. Mount the operator mounting bracket to the operator using the supplied fasteners.
5. Mount the operator-mounting bracket to the operator bracket according to the shop drawings using the supplied fasteners.
6. Install controls and wire the operator. Refer to the wiring diagram provided with the operator for proper connections and voltages. The controls should be installed in an area from which the door/opening is clearly visible. This will allow an individual operating the unit to make a visual inspection of the opening for any obstacles or other potential hazards before setting the door into motion.

**Note:** Do not attempt to set the upper and lower limits until the curtain is installed.

### ▪ Applying Spring Turns (not including chain sprocket adjusters):

1. Refer to the job information or markings on the shaft for the number of spring turns required on the unit.
2. To apply spring charge, remove cotter and stop pin from adjusting wheel.

**Note:** SA0005 adjustors require the use of an adjustor bar as a stop as well as a 3/8" thick x 2" wide x 30" to 40" long A36 steel bars to apply spring torque. See **Figure 6.1**.

3. Using two 1/2" diameter (or greater depending on the adjusting wheel) steel rods, approximately 18"-24" long, apply spring torque by inserting both rods into adjustor wheel one above the other.
4. Rotate wheel in a direction of raising the curtain. Maintain applied torque with upper rod, while removing lower rod. RE-insert this rod above the other and continue applying torque one notch at a time using this hand over hand procedure until the specified number of spring turns has been applied.

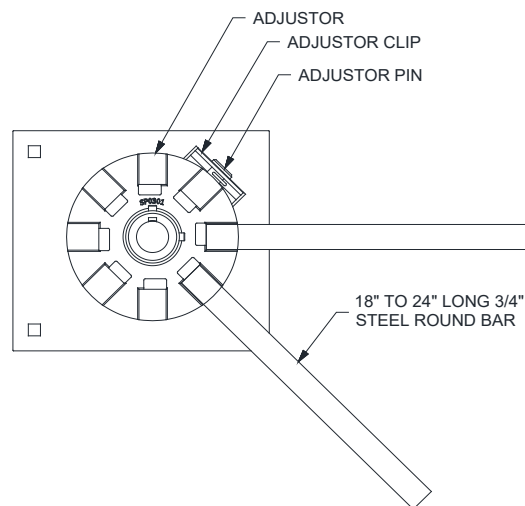
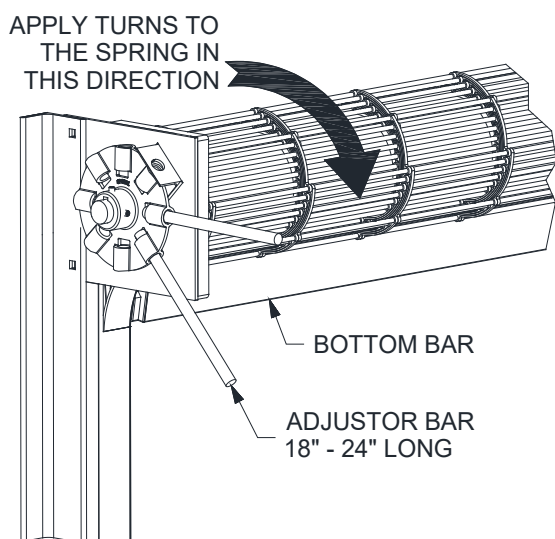

**Figure 6.1 – SA0005 Spring Adjustor**

## Section 6 – Motor Operator Installation

5. Replace stop pin or bar into adjuster wheel as shown in **Figure 6.3** and insert the cotter pin to hold it in place.
6. The spring should now hold the door in the open position. Remove any devices applied to hold the door in the open position (clamps, slings, vice grip, etc.)
7. Check curtain for ease of operation. If the door operates correctly, skip to the next section, if not, continue to the next step.
8. Final spring tension adjustment, if necessary, should be increased or decreased with the curtain in the fully open position. Insert one [two if necessary]  $\frac{1}{2}$ " diameter steel rods into adjuster wheel.
9. Remove cotter pin and stop pin from adjuster wheel and begin to increase or decrease tension.
  - To increase tension, rotate the wheel in the direction of raising the curtain.
  - To decrease tension, carefully rotate the wheel in the direction of lowering the curtain.
10. Recheck the balance in 1/8 rotation increments (one notch at a time). Re-insert stop pin and cotter pin.

**Note:** If you have difficulty balancing the door, or the number of turns required to balance the door varies significantly from the quantity provided, contact the **Service Department**.



**Figure 6.2 – Clamping the Guides, Applying Turns**

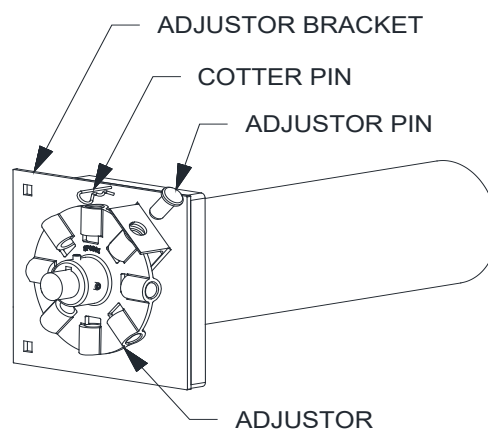

**Figure 6.3 – Pinning the Adjusting Wheel**

## Section 7 – Hood Support Installation

### ▪ **Hood Support installation:**

1. Refer to the job information to determine the type and quantity of hood supports required for your door. Hood supports will be noted on the elevation view of the job construction drawings. See **Figure 7.1** for hood support types.

**Figure 7.1 - Hood Supports**

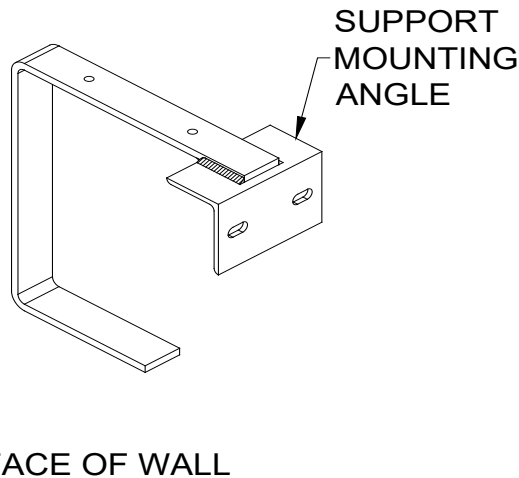

2. Determine where the support(s) will be located between the guides.
  - a. If multiple supports are required, see the job construction drawings to determine the centerline of each.
  - b. If a single support is required, it will be located at the center of the unit.
3. Mark a line on the lintel or ceiling (for units without a lintel) at the centerline of each support.
4. Check the construction at the support locations to be sure it is strong enough to handle the weight of the hood.

**Note:** *If the construction is not strong enough, do not proceed until rectified.*

5. The term “top of the coil” refers to the top edge of the brackets and hood which house the curtain (The curtain in the fully open position is referred to as the “coiled curtain”. The top of the coiled curtain is not actually located at the “top of the coil”, it is lower than the top of the coil) Locate the “top of the coil”:
  - a. This is typically at the top of the wall angle or intermediate angle.
  - b. If there is no wall or intermediate angle, see the job construction drawings for the distance from the bottom of the unit to the top of the coil.
  - c. If there is a ceiling at the top of the coil, skip the next step.
6. Mark a line at the top of the coil at both guides of the unit. Project the lines together to make a continuous line.
  - a. This will help locate the top of the hood support which will keep the hood level.
7. If there is no lintel/header, the hood support will be located based on the fascia side of the guide.
  - a. If the unit is between jambs with 4-angle guides, a fascia mounting channel is typically provided.
  - b. If the unit is between jambs with 2-angle guides mounted to a tube, a fascia mounting channel is not provided, and the fascia is mounted to the fascia side of the tube.
8. Project a line from the fascia mounting location (fascia mounting channel or fascia side of the tube) from one guide to the other.
9. Mark a line at the support centerline along the fascia line.
10. Prepare the location of the attachment point of the support(s) prior to installing the barrel. This will make installing the support much easier when the time comes to attach it to the lintel/header or ceiling.
  - a. Hold the support in place at the determined location and mark the mounting hole locations.
  - b. Drill holes in the construction.
11. Attach the hood support to the lintel/header or ceiling to be sure the mounting holes were located properly.
12. Remove the hood support and proceed to the **“Barrel and Brackets”** section.
13. Once the barrel, brackets, curtain are installed, and necessary testing was done on the unit, re-install the hood support.

## Section 8 - Hood, Fascia, and Covers

### ▪ **Hood and Fascia Installation:**

1. Determine what type of hood is provided. See **Figure 8.1** for possible hood configurations. This can be done by:
  - Looking at the brackets and identifying a half-circle shaped flat (D-shaped hood) or straight flats (square or sloped).
  - Looking in the hood box and comparing to the job construction drawings.

**Figure 8.1 - Hood Configurations**

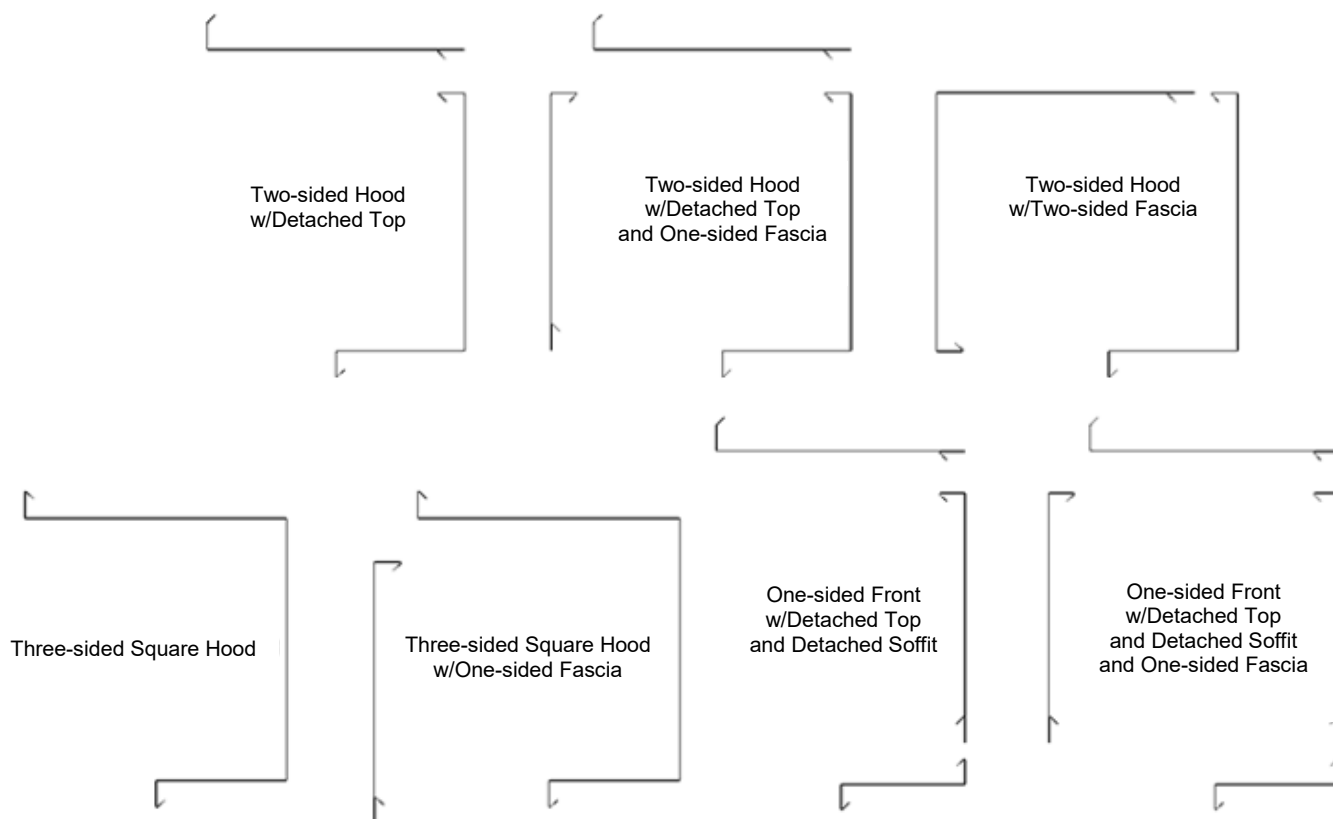

1. If no fascia is included, skip to Step 3.

If a fascia is included, it will be installed first. Fascia fastening varies by job condition but is typically secured to the guides, the brackets, or to the wall. Install the right-most section first, ending in “-R”. Continue leftward adding fascia sections, overlapping the right-hand section by 4”

2. If the hood has more than one section (separate left, right, or center), skip to Step 5.

For single-section hoods, begin with the front-most piece. Install by holding the hood up to the coil area and pushing it against the flats on the brackets. Center the hood so the gap is the same at both brackets. Pre-drill with a #21 or 5/32” drill in at least one place on every face of the hood, at both the left and right sides. See **Figure 8.3** for recommended fastener locations.

3. After fastening the first hood piece, continue with the detached soffit and top, if included.
4. For hoods with multiple sections, begin with the front-most right-hand hood piece, ending in “-R”.

Install by holding the hood up to the coil area and pushing it against the flats on the brackets. Butt the hood piece against the bracket to minimize the gap. Pre-drill with a #21 or 5/32” drill in at least one place

## Section 8 - Hood, Fascia, and Covers

on every face of the hood, at both the left and right sides. See **Figure 8.3** for recommended fastener locations.

The hood section should cover the hood support completely (approx. 4"). Temporarily clamp hood section to hood support until the next section is installed.

5. Continue leftward installing sections of the same type of hood piece before starting with the right-most soffit or top pieces. See **Figure 8.2** for an example of the order hood pieces should be installed. No cover is used on the splice between hood sections.

**Figure 8.2 – Multiple Hood Sections**

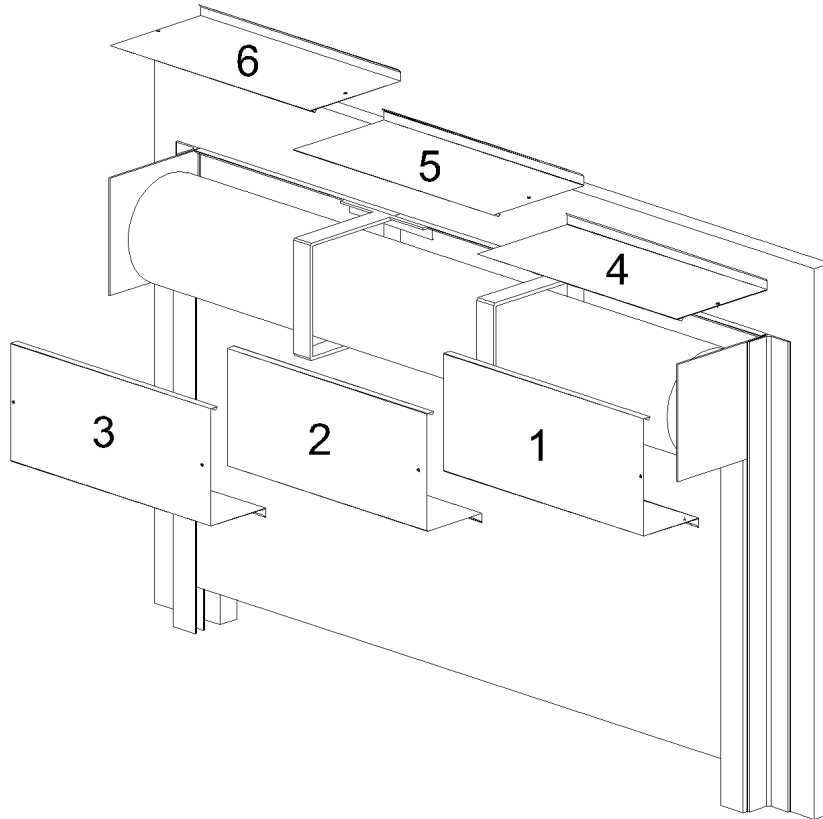

Section 8 - Hood, Fascia, and Covers

**Figure 8.3 – Recommended Fastener Locations**

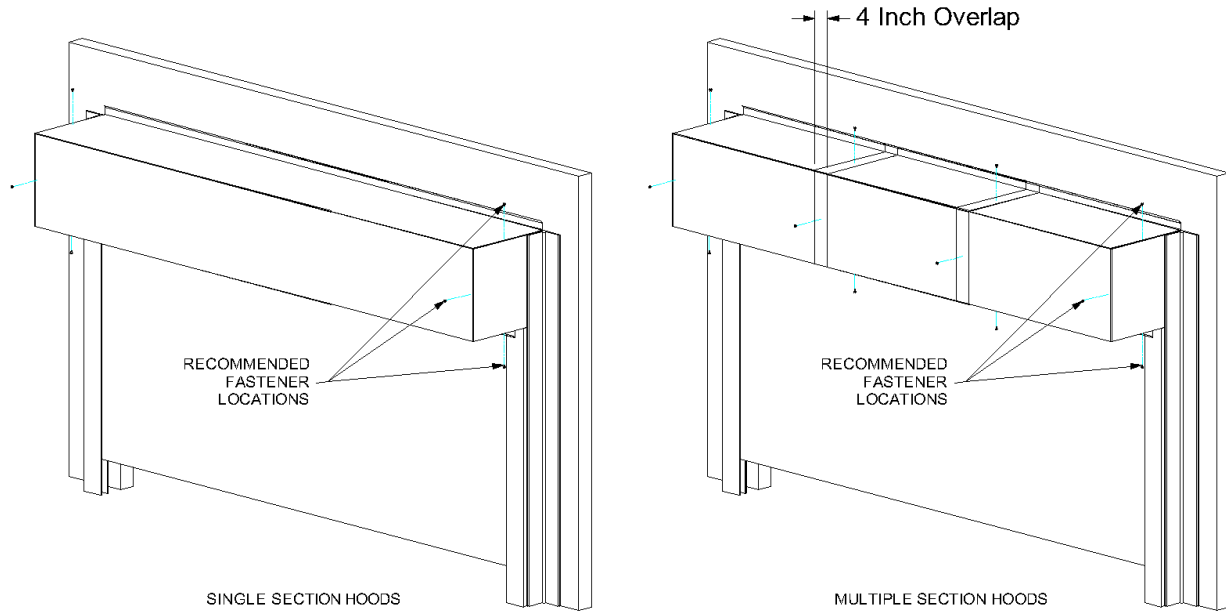

6. If the door is mounted in a weathered or exterior location, caulk the part of the hood that contacts the wall.

## Section 8 - Hood, Fascia, and Covers

### **Cover installation:**

1. Once the unit is installed and operating correctly, the covers can be installed.
2. Hood screws may have to be removed and reinstalled to install covers properly.
3. If the cover mounts to the side of the door bracket, pre-drill holes in the bracket to ease installation. A #21 drill size is recommended.
4. If an operator or adjustor cover is provided, individual installation instructions are provided with each cover along with the necessary hardware to attach the cover.
5. Once the cover is installed, operate the door a few more times to be sure there is no interference between the moving components inside the cover and the cover itself.
6. If the door is mounted on the exterior of the building, a bead of silicone sealant should be applied around the entire perimeter of the cover, as it will provide additional protection to the door components.

## Section 9 - Torque Specifications

**Table 9.1 - Torque Recommendations for Guide Assembly and Wall Fasteners**

Bolt size/type	Torque (ft lbs) <sup>a</sup>
1/4-20 Grade 2 steel bolt	6
5/16-18 Black Oxide Socket Cap	25
3/8-16 18-8 stainless steel bolt	20
3/8-16 Grade 2 steel bolt	20
3/8-16 Grade 5 steel bolt	31
3/8-16 Grade 8 steel bolt	45
1/2-13 Grade 5 steel bolt	75
1/2-13 Grade 8 steel bolt	107
5/8-11 Grade 8 steel bolt	212
3/4-10 Grade 8 steel bolt	376
<sup>a</sup> The recommended torque for steel bolts is based on a plated bolt that has not been lubricated.	

**Table 9.2 - Torque Recommendations for Solid Masonry Wall Anchors**

Anchor Size (nominal)	Manufacturer/Torque (ft lbs) <sup>a</sup>	
	Simpson Wedge-All	Hilti-Kwik Bolt 3
3/8	30	20
1/2	60	40
5/8	90	85
3/4	150	150
<sup>a</sup> Torque values for grout filled block are different, reference bolt manufacturer for these values.		



## Section 10 - Maintenance Schedule

▪ **Maintenance Schedule:**

**Note:** If any of the following problems exist, do not operate the door until repaired.

Component	What to look for and how often the components must be inspected:	Weekly	Monthly	Quarterly	What to do if problem exists:
Curtain & Bottom Bar	Are any curtain components damaged (slats, endlocks, etc.)?	X			Contact Service about replacing damaged parts.
	Is bottom bar damaged?	X			Contact Service about replacing damaged parts.
	Are bottom bar fasteners in place and properly tightened?		X		Fasteners must be inspected/replaced and properly tightened.
	Are fasteners attaching curtain to the barrel in place and properly tightened?		X		Fasteners must be inspected/replaced and properly tightened.
	Do you notice any hang-ups, jamming or other problems preventing the door from moving smoothly throughout the opening?	X			Check for external issues, if none exist, contact Service.
	Do you notice any odd or excessive noise when the door is operated?	X			Check for external issues, if none exist, contact Service.
	If there is a bottom seal, is it damaged?		X		Contact Service about replacing damaged parts.
	If there is locking, does it function properly?	X			Check for external issues, if none exist, contact Service.
Brackets	Are brackets plumb and perpendicular with wall?			X	Contact Service.
	Are bracket fasteners in place and properly tightened?			X	Fasteners must be inspected/replaced and properly tightened.
	Do you notice signs of excessive wear on the bearings (i.e. binding, excessive noise, etc.)?		X		If there is a grease fitting, apply grease, if not, contact Service.
	Is adjusting wheel & pin secure?			X	Contact Service.
	Is drive chain sufficiently lubricated?			X	Apply chain lube.
	Is drive chain in need of tightening?			X	Contact Service for instructions on how to tension the chain.
	Is drive or driven sprocket damaged?		X		Contact Service about replacing damaged parts.
Guides	Are wall fasteners in place and properly tightened?		X		Fasteners must be inspected/replaced and properly tightened.
	Are guide assembly fasteners in place and properly tightened?		X		Fasteners must be inspected/replaced and properly tightened.
	Is guide gap dimension correct?		X		Check job construction drawings and adjust gap as required. If job construction drawings are not available, contact Service.
	Are any of the guide parts bent or damaged?		X		Contact Service.
	Are stoppers loose, damaged, or missing?		X		Stoppers must be inspected/replaced and properly tightened.
Hood and Fascia	Is hood/fascia dented or damaged?			X	Remove hood/fascia. Repair if possible. If not leave hood/fascia off and contact Service.
	Is curtain rubbing against the hood/fascia?	X			Hood/fascia may have been damaged. Contact Service.
	Is hood/fascia level?			X	Check fasteners, they may be loose or missing. Replace as soon as possible.
	Are guide assembly fasteners in place and properly tightened?		X		Fasteners must be inspected/replaced and properly tightened.
	Is hood support level?			X	Check fasteners, they may be loose or missing. Replace as soon as possible.

## Section 10 - Maintenance Schedule

Door operation	Does the door require excessive force to open?		X		Check for hang-ups or obstructions. Ensure spring tension is set correctly. Contact Service.
	If the door contains locking, does the locking mechanism function properly and securely hold the door in the closed position?		X		Check for damage and other external issues. Contact Service.
	If there is a sensing edge, does it function properly?	X			Cut power and check for loose wires. Contact Service for further instruction.
Motor Operator	Are the fasteners attaching the motor-to-the mounting bracket, and mounting bracket-to-the door bracket secure?			X	Fasteners must be inspected/replaced and properly tightened. Contact Service for replacement hardware.
	Are the sprockets properly aligned?			X	Realign the sprockets as secure using the set screws. Recheck chain tension.
	Are the sprocket keys properly aligned with sprockets and securely fastened with the set screws?			X	Reposition the keys so they fully engage the keyway in the sprocket. Tighten the set screws.
	Is the door stopping correctly at the open (before bottom bar contacts the stoppers) and closed (as soon as the bottom bar contacts the floor) positions?		X		Limits may have to be adjusted in the motor operator. Refer to the operator owner's manual or contact Service.
	Is the operator functioning normally?		X		Refer to the <i>Operator Troubleshooting Table</i> on the following page to diagnose the problem.

## Section 10 - Maintenance Schedule

▪ **Operator Troubleshooting:**

**Note:** If you suspect you are having an issue with your operator, use the following table to determine the potential causes. If the provided solution does not eliminate the issue, or the table does not address your particular problem, contact the Service Department.

Component	Problem	Potential Cause	Solution
Motor Operator	Motor Operator does not run when OPEN or CLOSE button is pushed	The circuit breaker may be flipped or fuse blown.	Reset breaker or replace fuse. Contact Service if replacement fuse is needed.
		The thermal overload may be tripped.	Reset thermal overload.
		Manual interlock switch is open (on units with emergency operator).	Close manual interlocks.
		External interlock may be opened.	Close external interlock.
	Motor operator runs but the door does not move	Sprocket key may be missing or drive chain may be broken.	Contact Service for repair parts. Install key or replace chain.
		Clutch may be slipping.	Adjust if possible. Contact Service otherwise.
	Motor hums but does not run	Door or drive chain may be jamming.	Check for hang-ups or obstructions. Try to operate manually. If issue persists, contact Service.
		Dead phase in 3 phase system.	Check power supply.
		Brake does not release.	Check power to brake solenoid.
		Open motor winding.	Check that all connections are secure.
	Motor operator runs in wrong direction and limits do not function	3 phase operator power supply is out of phase.	Interchange any 2 power leads to unit.
	Door drifts when motor shuts off	Brake may be improperly adjusted or broken.	Check brake components. Contact Service for replacement parts or adjust instructions.
	Motor operator does not shut off at full OPEN or at full CLOSE position	Limits may need adjustment.	Refer to the operator owner's manual to readjust limits.
		Sprocket on limit shaft may be slipping or limit drive chain may be broken.	Ensure sprocket key is correctly installed and set screws are tightened. Contact Service for replacement chain if broken.
Limit switch may be defective.		Contact Service.	
Limit Switches	Limit switch does not hold setting	Drive chain may be too loose, allowing the chain to jump sprocket teeth.	Adjust chain to proper tension. Contact Service for additional information.
		Limit nut retainer not engaging slots in limit nuts.	Be sure retainer is securely engaged in slots of both limit nuts.
		Limit nuts binding on screw threads, allowing them to jump position on retainer.	Lube screw thread. Check that limit nuts turn freely.

## Section 11 – Curtain Repair

### ▪ **Assess the curtain damage:**

1. Locate and determine the sections of the curtain that are damaged (Rods, Links and Spacers).
  - a. Bring the door to the fully closed position. Inspect the curtain attachment to the barrel for damage.
  - b. Coil the curtain up one revolution and inspect for damaged links and/or rods. Make note of sections that do not nest like shown in **Figure 11.1**. Continue to inspect entire curtain by coiling up one revolution at a time until door is in fully open position.

***Figure 11.1 – Curtain Nesting***

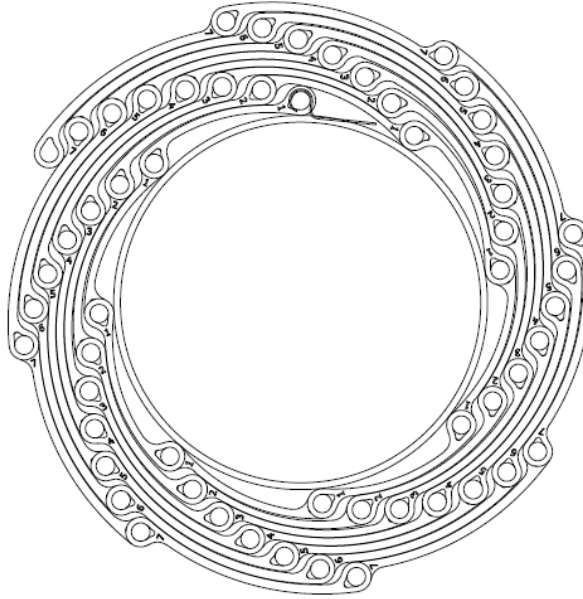

- c. Carefully inspect the section above and below the identified damage section. When a door is cycled with a damaged area, it's likely that the sections above and below the damaged area will be damaged as well.
    - d. It's important to note that cycling with damaged links can cause more damage to other areas of the curtain.
  2. The sections can be determined by locating the link number on the side of the link as shown in **Figure 11.2**. This information is necessary when contacting the service department for replacement of damaged sections.

***Figure 11.2 – Link Number***

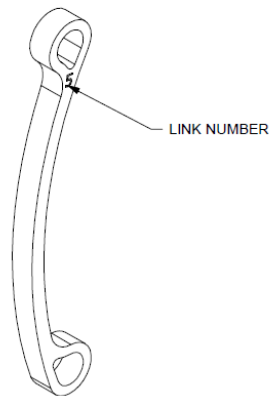

## Section 11 – Curtain Repair

### ▪ **Curtain Repair:**

1. Move door to the full open position, avoiding further damage to curtain.
2. Shut off power.
3. Loosely strap the coiled curtain to prevent bottom bar from dropping over backside in next steps.
4. Hand chain the door so the bottom bar is up and out of the guide assembly, in the 12 o'clock position as seen in **Figure 11.3**.
5. Continue to rotate coiled curtain until bottom bar goes over the top and is in the 3 o'clock position.

***Figure 11.3 – Strapping Curtain***

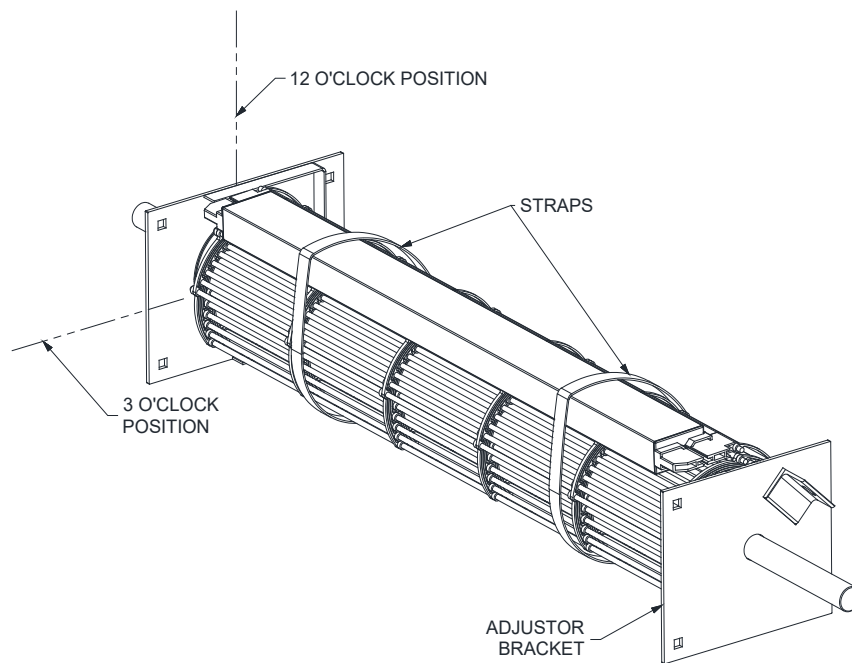

6. Remove straps at the 3 o'clock position and slowly lower the bottom bar by hand to its resting position.
7. Hand chain the curtain down, outside the guides, to a comfortable working height.
8. Identify the rod that will be removed; see **Figure 11.4**. This can be done by locating the change of link number. It is important to note that per section, only 8 links of any one link type/number is used.

***Figure 11.4 – Removing Rod***

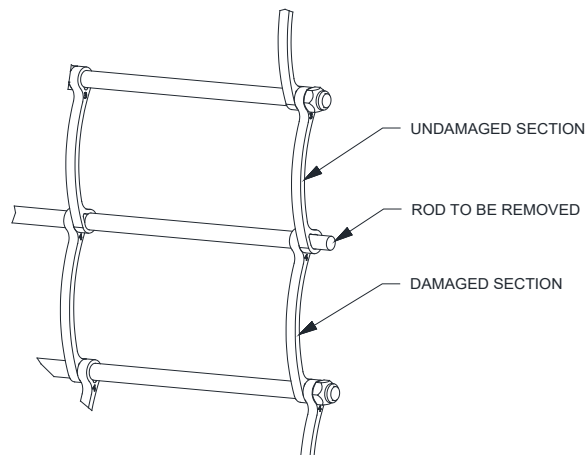

## Section 11 – Curtain Repair

9. Use zip ties as shown in **Figure 11.5** to relieve curtain weight on the rod to be removed. This can also be achieved by using a strap over the shaft when the curtain section(s) are too heavy for zip ties.

**Figure 11.5 – Removing Rod**

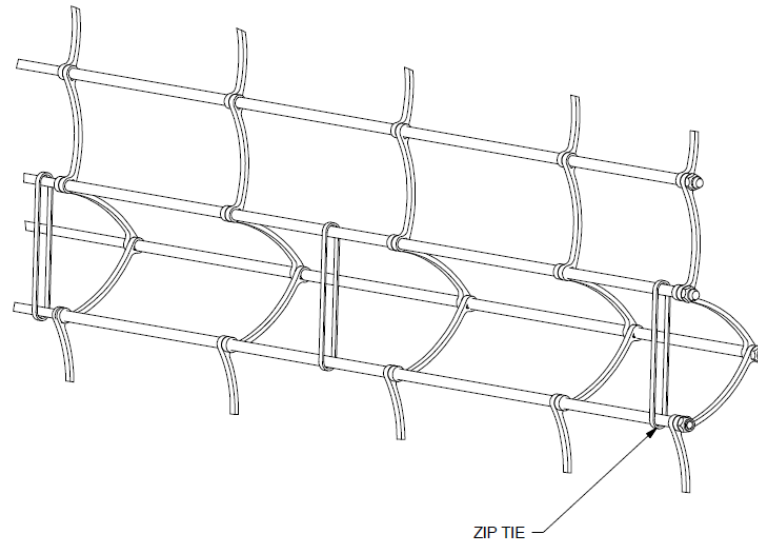

10. Remove the threaded nut on the rod ends.
11. Slide out the rod and remove the damaged section.
12. A new rod will be supplied with the replacement section. Use the new rod to attach the replacement section. Use zip ties to relieve curtain weight so rod will slide through links easily.
13. It's very important to maintain the link pattern when replacing a section by visually inspecting the replacement section to make sure it conforms to the existing pattern/orientation as shown in **Figure 11.6**. This can be done by matching the orientation, link number location and curvature to links above and below the section being replaced.

**Figure 11.6 – Link Orientation**

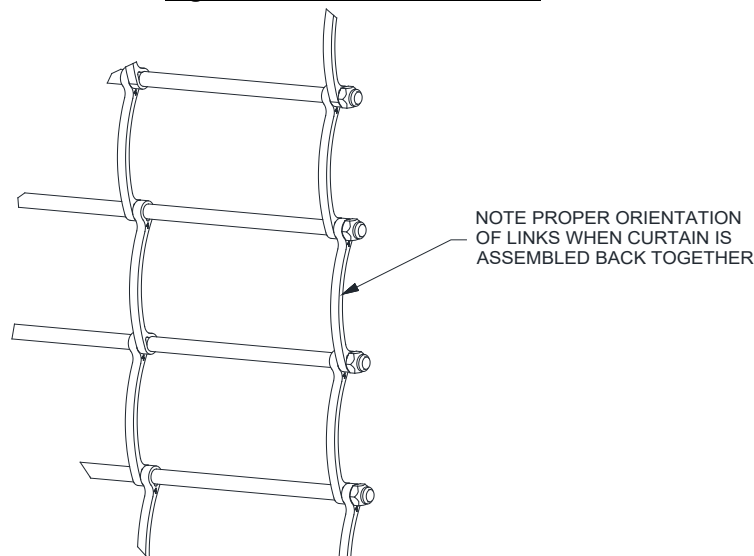

14. Install and tighten threaded nut (provided) on the rod ends and remove zip ties used in previous steps.
15. Hand chain curtain up to open position.
16. Lift bottom bar up, by hand, to 3 o'clock position and strap in place.
17. Perform steps in reverse order to get curtain back into guides and power up door.