

HIGH PERFORMANCE LINE

EXTREME[®] 300 SERIES MICROCOIL[®] GRILLE

Model EPG324C

MEASURE THE WIDTH AND HEIGHT OF THE OPENING

STAINLESS STEEL CURTAIN

DOOR SIZE AND AREA

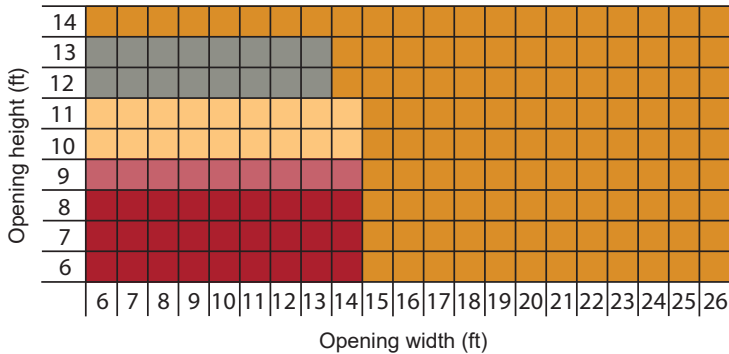

COMPONENT DIMENSIONS

	A	B	C	D	E
	10 1/2"	12 1/2"	FOW = 5 3/4" BJ = 5 3/4"	FOW = 12 3/4" BJ = 13 1/2"	2"*
	10 3/4"	12 3/4"			
	11"	13"			
	11 1/2"	13 1/4"			
	11 3/4"	13 3/4"			

*Dimension is 3" if a sensing edge is present

ALUMINUM CURTAIN

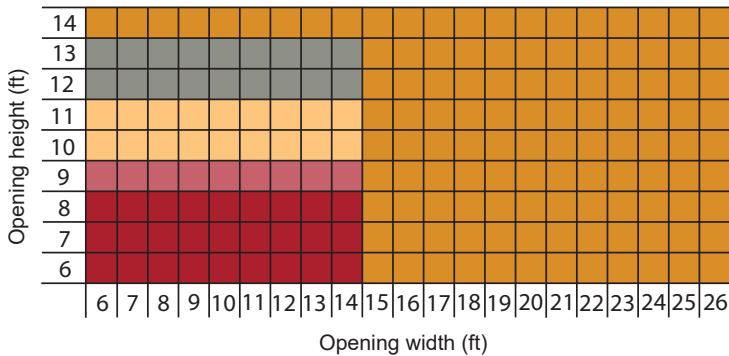

	A	B	C	D	E
	10 1/2"	12 1/2"	FOW = 6" BJ = 6"	FOW = 13 1/4" BJ = 13 3/4"	2"*
	10 3/4"	12 3/4"			
	11"	13"			
	11 1/2"	13 1/4"			
	11 3/4"	13 3/4"			

*Dimension is 3" if a sensing edge is present

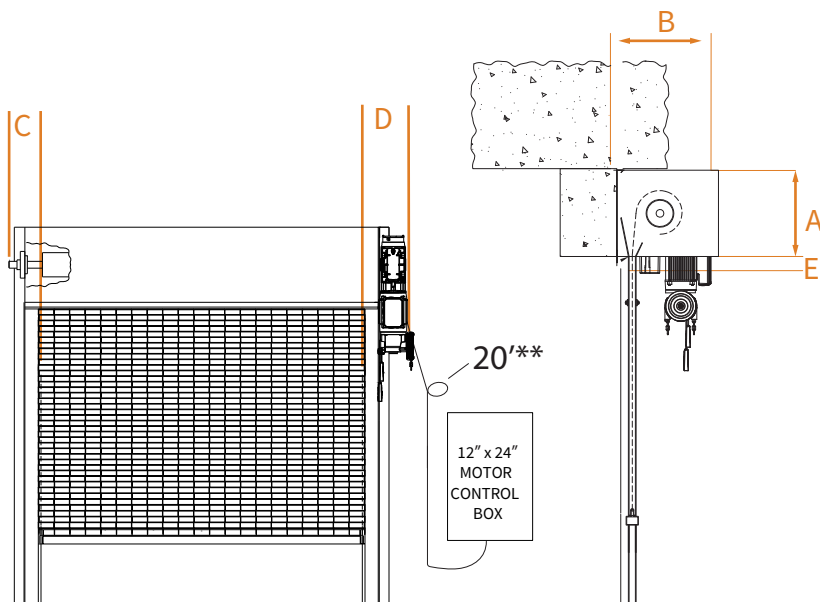

**Additional lengths are available, please contact the factory.

CURTAIN DESIGNS Straight and Brick

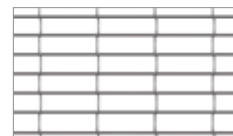

Straight

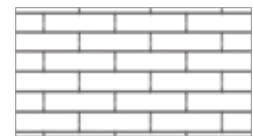

Brick

The dimensions featured on this sheet are provided as a rough guide for planning purposes. Exact dimensions cannot be provided until field conditions and all options are confirmed. Once field conditions are confirmed, please visit our website at www.cooksondoor.com/drawings to generate custom drawings on demand for your specific opening.

FACE OF WALL GUIDE CONSTRUCTION OPTIONS

STAINLESS STEEL

Z GUIDE

Typically used with masonry wall construction, guides are mounted to the interior or exterior side of the wall.

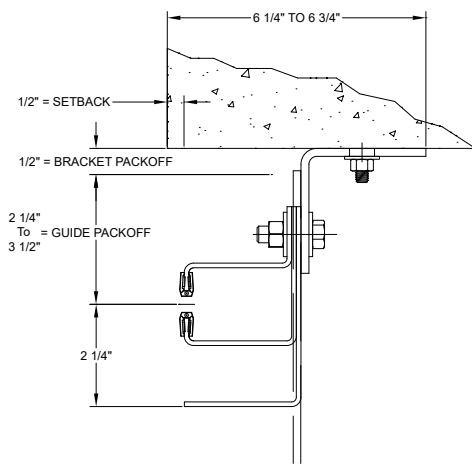

E GUIDE

Typically used with steel jambs, guides are mounted to the interior or exterior side of the wall.

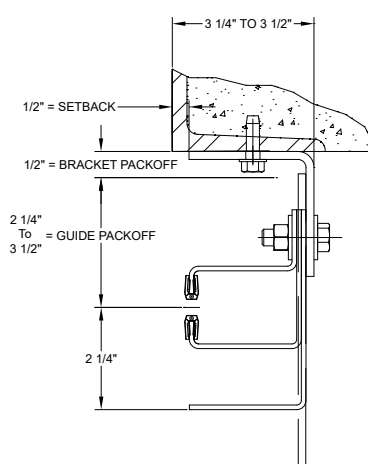

Z GUIDE TO TUBE

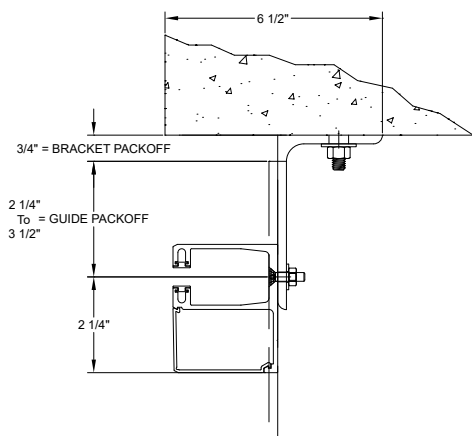

E GUIDE TO TUBE

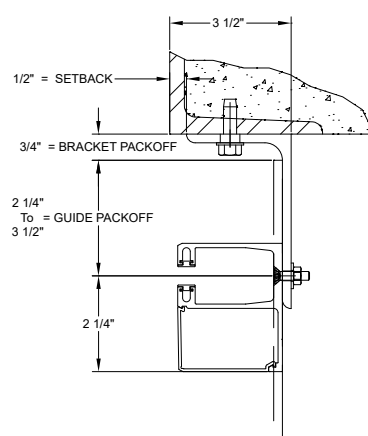

BOTTOM BAR

Compact stainless steel 300 series in #4 finish.

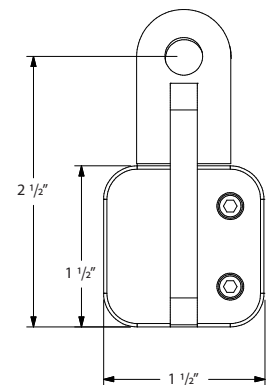

The dimensions featured on this sheet are provided as a rough guide for planning purposes. Exact dimensions cannot be provided until field conditions and all options are confirmed. Once field conditions are confirmed, please visit our website at www.cooksondoor.com/drawings to generate custom drawings on demand for your specific opening.

FACE OF WALL GUIDE CONSTRUCTION OPTIONS

ALUMINUM

Z GUIDE

Typically used with masonry wall construction, guides are mounted to the interior or exterior side of the wall.

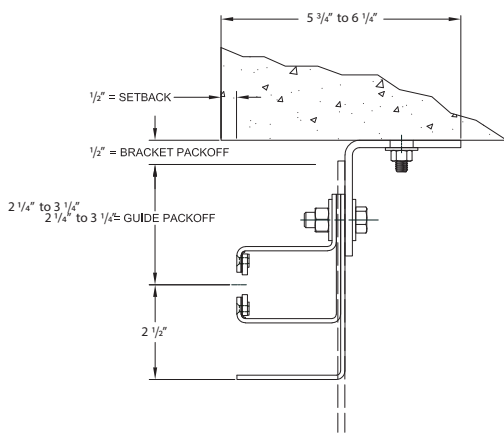

E GUIDE

Typically used with steel jambs, guides are mounted to the interior or exterior side of the wall.

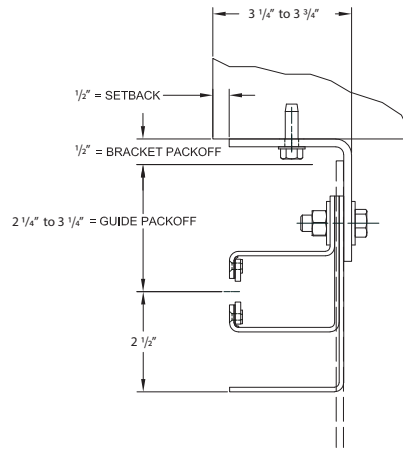

Z GUIDE TO TUBE

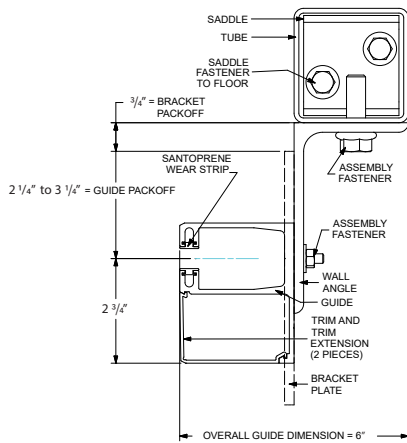

E GUIDE TO TUBE

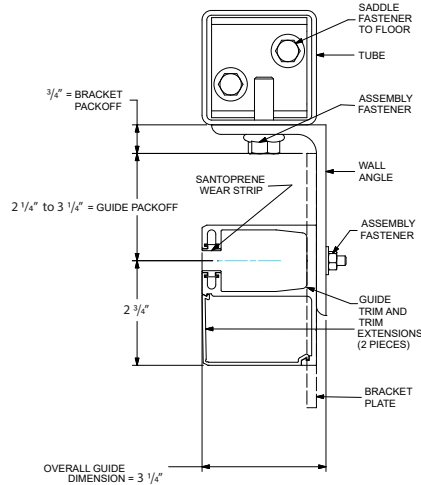

BOTTOM BAR

Compact extruded aluminum in mill finish.

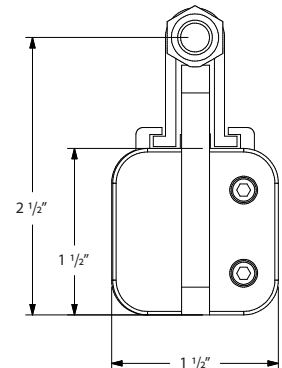

BETWEEN JAMBS GUIDE CONSTRUCTION OPTIONS

STAINLESS STEEL

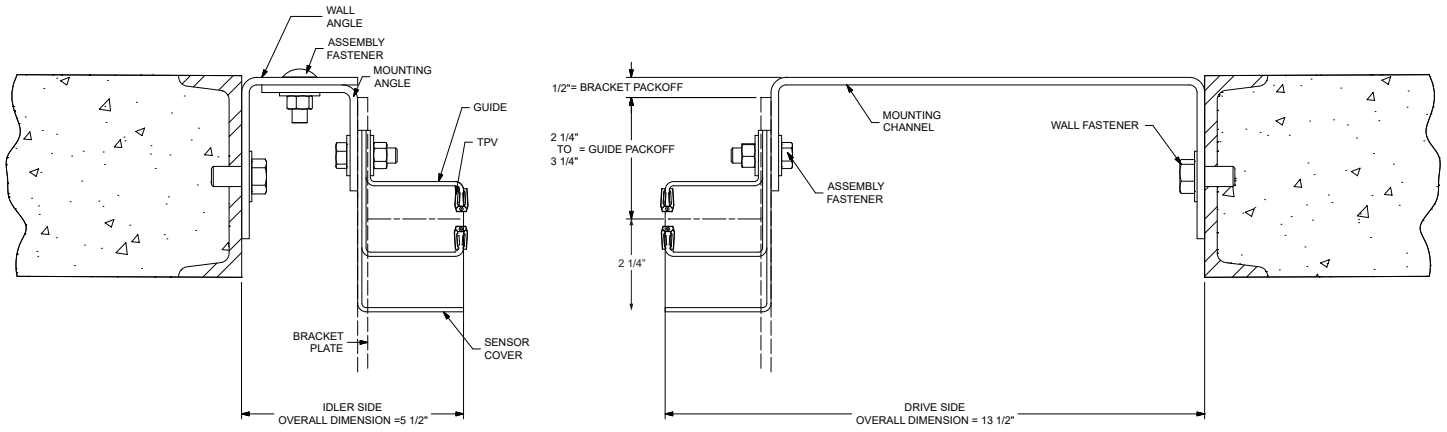

ALUMINUM

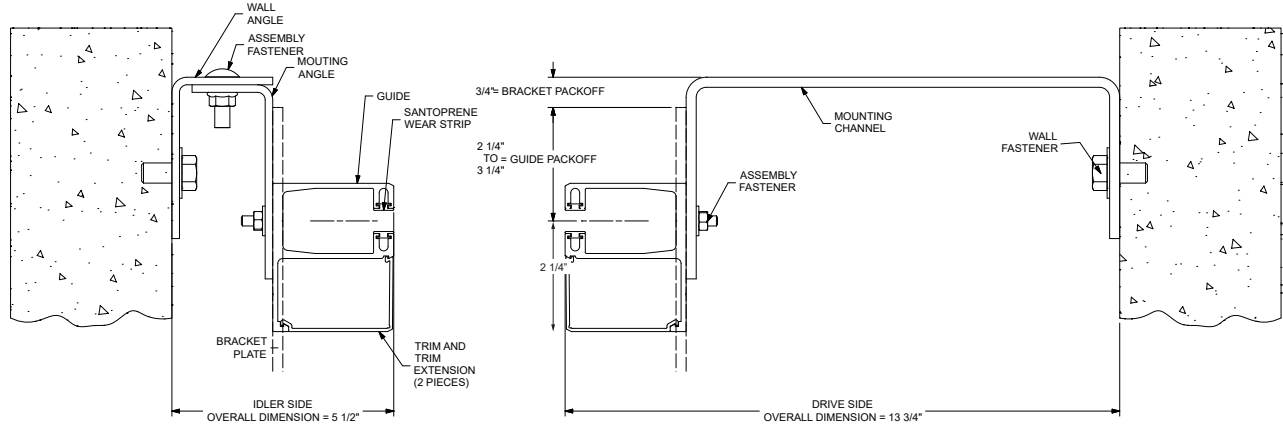

OPERATIONAL WIND LOAD LIMITS

Stainless Steel

Max. DBG	Max. operational wind load (PSF)
12'	16
20'	12
26'	10

Aluminum

Max. DBG	Max. operational wind load (PSF)
12'	11
20'	10
26'	9

CUSTOM-DESIGNED SOLUTIONS

Our experienced Architectural Design Support Team can customize our products to fit your specific application. Call 800.233.8366 ext. 4551 • architecturaldesignsupport@cornellcookson.com