

FIRE RATED COUNTER DOOR

Models ERC10 & ERC 11 (SmokeShield®)

MEASURE THE WIDTH AND HEIGHT OF THE OPENING

DOOR SIZE AND AREA*

The maximum limits listed in our UL procedure are for counter fire shutters up to 16'-0" wide, 10'-0" high or a 120 sq ft maximum. If the counter shutter is over 12' wide the limit is 7'6" high.

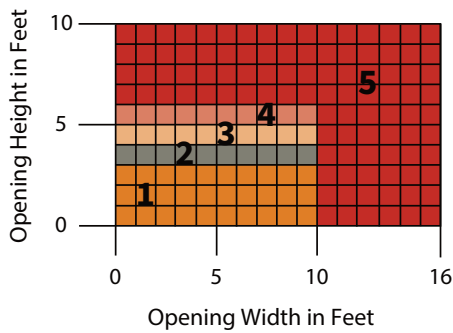

*Chart based on 22 gauge steel slats.

COMPONENT DIMENSIONS

Reference the zone number to view component dimensions for in tube hand crank and tube motor-operated units. Alternate operation methods increase headroom and sideroom requirements. Upset (zone E) is calculated with a single angle bottom bar. Sensing edges add 1" of upset. Tubular bottom bars add 2.25" of upset.

Dimensions in Inches

1	8.5	8	2	1.75	.25
2	9	8.5	2	1.75	.25
3	9.5	9	2	1.75	.25
4	10	9.5	2	1.75	.25
5	10.5-14.5	10-14	2	1.75	.25

Zone A B C D E

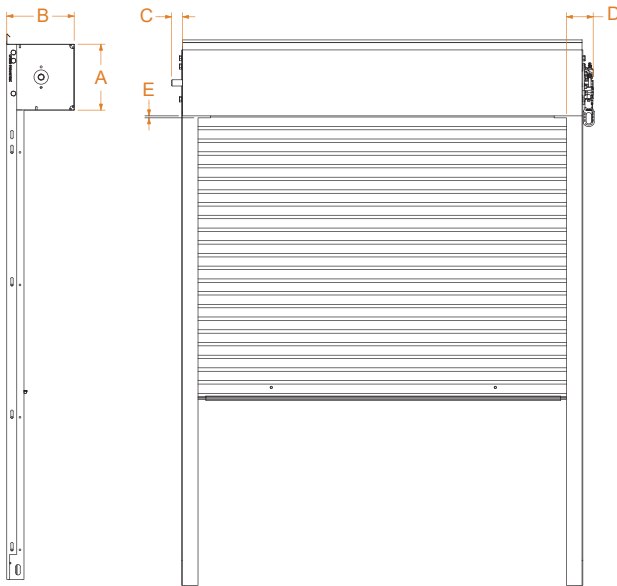

SLAT DESIGN

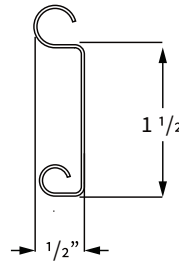

ANGLE BOTTOM BAR

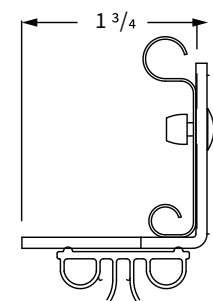

TUBULAR BOTTOM BAR

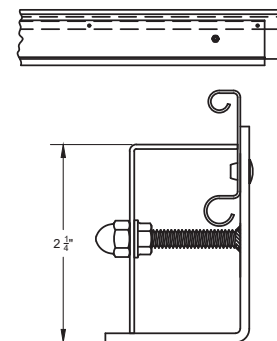

The details and dimensions on this sheet are provided as a rough guide for planning purposes. Project specific details and dimensions are available by generating drawings from our website: www.cooksondoor.com/drawings

FIRE PROTECTIVE CLOSURE **FIRE RATED COUNTER DOOR Models ERC10 & ERC11**

GUIDE CONSTRUCTION OPTIONS

3" SHAFT FACE OF WALL

Guides are mounted to the interior or exterior side of the wall.

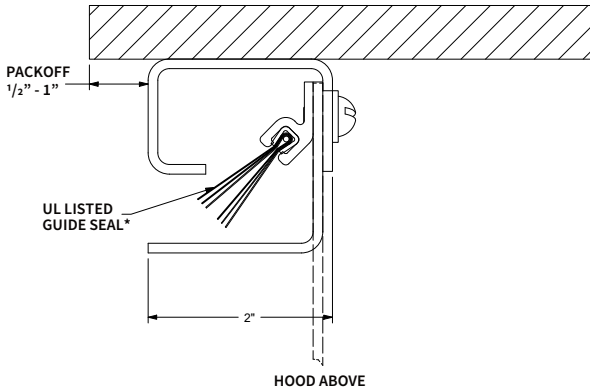

3" SHAFT BETWEEN JAMBS

Guides are mounted to the inside of the jamb.

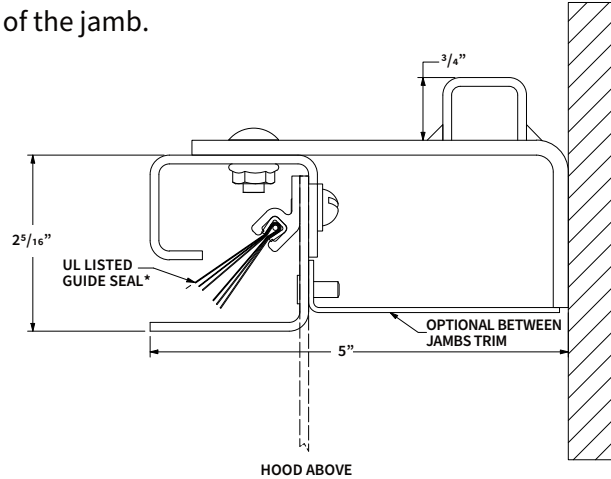

4" SHAFT FACE OF WALL

Guides are mounted to the interior or exterior side of the wall.

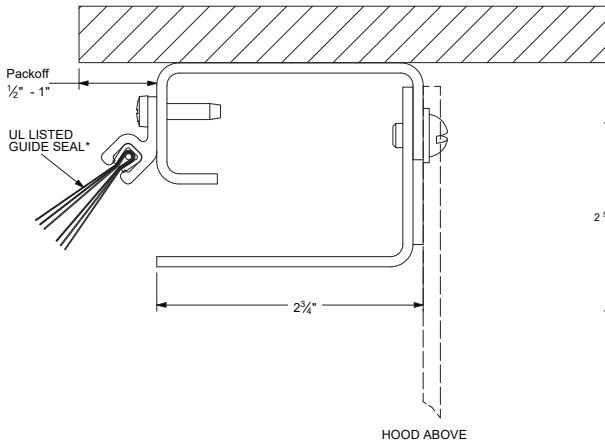

4" SHAFT BETWEEN JAMBS

Guides are mounted to the inside of the jamb.

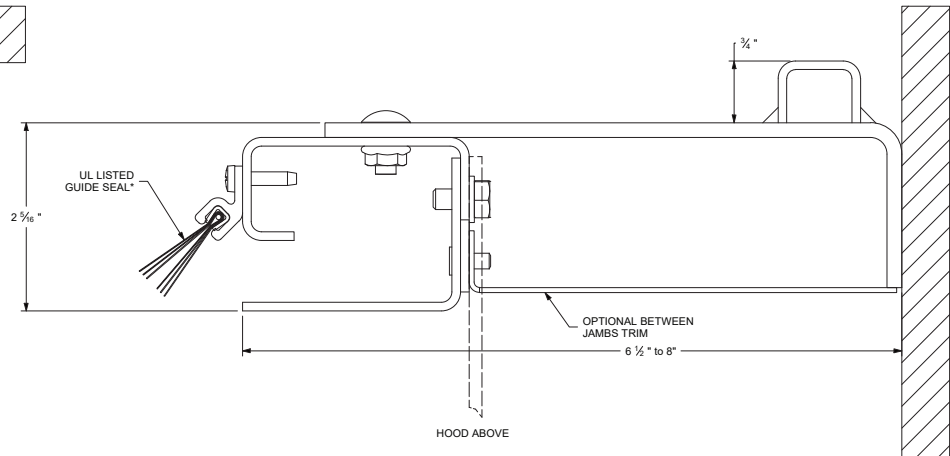

*The UL listed guide seal is standard on model ERC11(SmokeShield®).

The details and dimensions on this sheet are provided as a rough guide for planning purposes. Project specific details and dimensions are available by generating drawings from our website: www.cooksondoor.com/drawings

CUSTOM-DESIGNED SOLUTIONS

Our experienced Architectural Design Support Team can customize our products to fit your specific application.

Call 800.233.8366 ext. 4551 • architecturaldesignsupport@cornellcookson.com

800.294.4358 | cooksondoor.com

CornellCookson, Inc. is an ISO 9001:2015 registered company

11.2024

Preferred door solutions.
COOKSON