

ROLLING COUNTER DOOR

ROLLING COUNTER DOOR

Models ESC10 & ESC20 (integral frame and sill)



AN ELEGANT, UNOBTRUSIVE WAY TO SECURE FINISHED OPENINGS

SMALLER COMPONENTS DELIVER A CLEAN, PROFESSIONAL APPEARANCE

Rolling Counter Doors are used in both interior and exterior applications. Built to exact opening specifications using compact guides, slats, brackets and hood, they offer a more streamlined look than traditional rolling doors. When a full door with compact door components is desired, full height units are available.

A GREAT CHOICE FOR SERVICE OPENINGS

Counter Doors are often used in cafeterias, stadiums, arenas, hospitality and educational facilities, public spaces, healthcare offices, and many other locations.

COUNTER DOOR PACKAGE UNIT WITH FRAME AND INTEGRATED SILL

Offering a flawless appearance and fast installation, slip-in units arrive ready to be set into existing walls. Units may be used in masonry or drywall openings from 4³/₄" to 13" thick.

COMPACT OPERATOR OPTIONS

Available as an option, concealed tubular motors provide a solution for strict dimensional limitations around the header or aesthetic requirements that lend themselves to its smaller, compact design.

800.294.4358 | cooksondoor.com

CornellCookson, LLC. is an ISO 9001:2015 registered company
5.2026

Preferred door solutions.[®]
COOKSON

ROLLING COUNTER DOOR **ROLLING COUNTER DOOR** Models ESC10 & ESC20 (integral frame and sill)

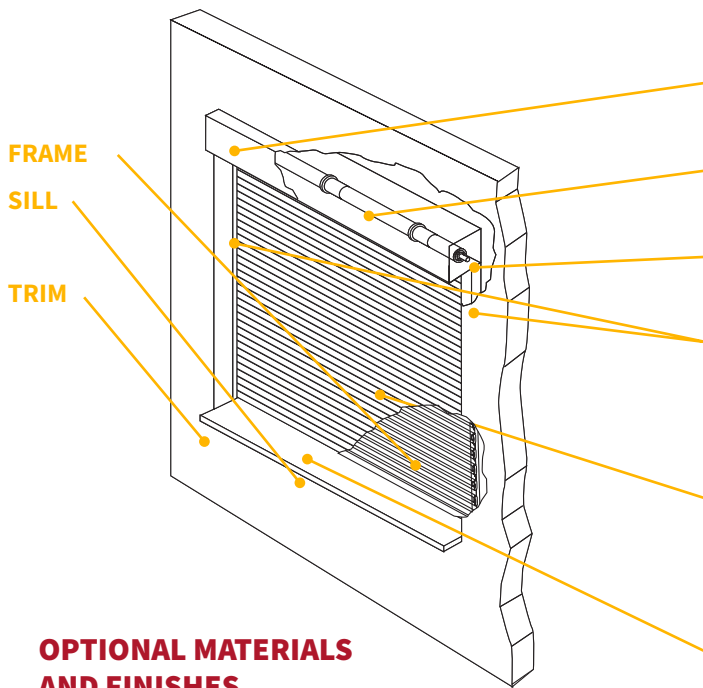

OPTIONAL MATERIALS AND FINISHES

- ▶ Aluminum in clear and color anodized - Only available for ESC10 model
- ▶ Stainless steel - 300 series in #4 finish
- ▶ SpectraShield® Powder Coating in more than 180 colors
- ▶ Although it is standard on the ESC10 model, Galvanized steel with GalvaNex™ polyester enamel finish is offered as an option on the ESC20 model
- ▶ For a more durable finish, consider upgrading to our GalvaNex Ultra™ or SpectraShield Ultra™ powder coat finish

Brackets, Guides and Bottom Bar

- ▶ Hot-dip galvanizing on steel components
- ▶ Zinc-enriched, corrosion-resistant powder coating in Gray

OPTIONAL WINDLOAD

The rolling counter door can be configured to withstand windload requirements of up to 40 PSF and impact ratings of up to 50 FPS.

STANDARD COMPONENT MATERIALS AND FINISHES

- HOOD** - Galvanized steel with GalvaNex™ polyester enamel finish to match curtain.
- COUNTER-BALANCE SHAFT** - Steel. Supports curtain and contains torsion springs for assisting operation.
- BRACKETS** - Steel with powder coating to match curtain. Bolt to guide assembly and support counter-balance shaft and curtain.
- GUIDES** - Two piece clear anodized extruded aluminum in clear anodized finish with polypropylene pile runners. Side rail assemblies bolt to the wall and support the entire weight of the unit.
- CURTAIN** - Galvanized steel with GalvaNex™ polyester enamel finish in Gray, Tan, Black, or White. Interlocking roll-formed flat-faced slats with end locks riveted to the ends of alternate slats to maintain curtain alignment and prevent wear.
- BOTTOM BAR** - Clear anodized extruded aluminum equipped with vinyl astragal/weather seal. Lock mechanisms available.

WITH INTEGRAL FRAME AND SILL

- HOOD** - Stainless steel
- BRACKETS** - Stainless steel
- CURTAIN** - Stainless steel
- FRAME** - Welded stainless steel head and jambs, guide groove is incorporated into jamb design
- SILL** - Stainless steel provides a seamless, custom look
- TRIM** - Stainless steel jamb trim angles, head trim optional

*All stainless steel is 300 series in #4 finish

OPERATION AND STRUCTURAL REQUIREMENTS

Hand-crank, push-up and a variety of motor options are available.

This product is supported by a guide assembly attached to the jamb construction. No additional header support is required unless hood supports are mandated by a larger opening width.

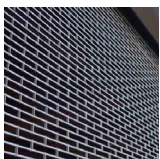

CUSTOM-DESIGNED SOLUTIONS

Contact our experienced Architect Design Support Team for help in customizing our products to fit your specific application.

 www.architectdoorhelp.com