

HIGH PERFORMANCE LINE

EXTREME® 1024 DOOR

Models EPD1024 & EPI1024 (insulated)

Compatible with



SmartSync™
Diagnostic Tool



1 MILLION CYCLES FOR HIGH USE OPENINGS

CONTINUOUS-DUTY DESIGN

The Extreme 1024 High Performance Door delivers reliable security, no maintenance (outside of routine checks) and an exceptional cycle life. It also offers extreme durability backed by a five year warranty.

SPEED YOU CAN COUNT ON

Tested to perform for more than a million cycles at an opening speed of up to 24" per second, 1024 doors operate **three times faster** than standard coiling overhead sectional doors.

PREFERRED APPLICATIONS

This door is a superior choice for high-security needs and high-use applications (distribution, government, manufacturing, parking, transportation, etc.), and accepts virtually all activation systems.

PROVEN RETURN ON INVESTMENT

1024 Doors provide the lowest lifetime cost and lowest cost-per-cycle versus other high-performance slatted products. Plus, their cost-per-cycle savings increase dramatically when compared to standard coiling doors often used incorrectly in high-cycle openings.

ENERGY EFFICIENCY

This door can maximize energy savings by quickly sealing your building during inclement weather to minimize air exchange. The insulated model features the patented Thermiser Max perimeter sealing system – which meets ASHRAE® 90.1², 2015 IECC® and California's Title 24 air infiltration requirements with an independently tested³ value of less than 0.3 CFM/FT².

800.294.4358 | cooksondoor.com

CornellCookson, LLC. is an ISO 9001:2015 registered company

9.2023

EXTREME SERIES

Preferred door solutions.®
COOKSON

HIGH PERFORMANCE LINE **EXTREME® 1024 DOOR** Models EPD1024 & EPI1024 (insulated)

STANDARD COMPONENT MATERIALS AND FINISHES

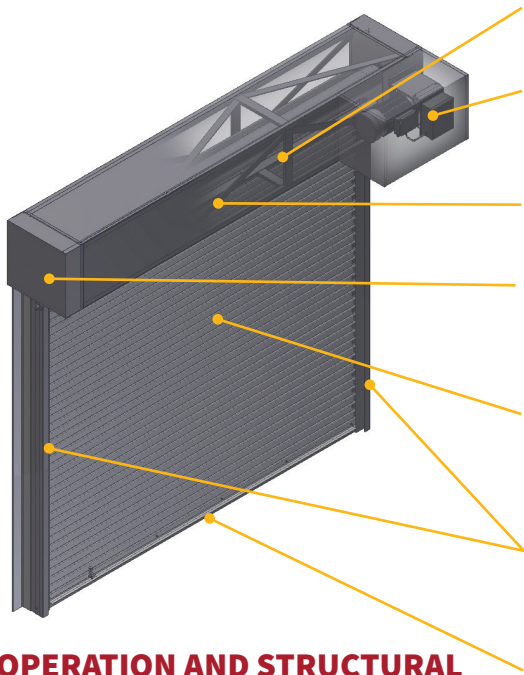

HOOD (optional) - Galvanized steel with powder coat finish to match curtain. Encloses the curtain and provides weather resistance at the head of the door.

MOTOR - UL listed, SEW Eurodrive TEFC NEMA 4 variable-speed motor and patented, high-performance brake prevents curtain from free falling in the unlikely event of operator component failure.

SPRINGLESS SHAFT - Steel. Design reduces maintenance requirements and facilitates cycle capacity.

BRACKETS/COIL BOX ASSEMBLY - Steel plate brackets are part of the unitized coil box assembly with the curtain and barrel. Access hatch for ease of servicing. Drive and tension brackets both furnished with precision ball bearings.

CURTAIN - Galvanized steel with rust inhibiting CycleShield™ powder coat finish in Gray, Tan, or White. Interlocking roll-formed slats with end locks riveted to ends of alternate slats to maintain slat alignment and prevent wear. Model EPI1024 features a foamed in place insulated curtain

GUIDES - Steel angles with powder coat finish to match curtain. Self-lubricating UHMW anti-wear strips greatly reduce friction and curtain wear. Perimeter-sealing, double brush weather strip.

BOTTOM BAR - Two back-to-back structural steel angles with powder coat finish in Gray, Tan or White.

OPERATION AND STRUCTURAL REQUIREMENTS

Motor operation required.

This product is supported by a guide assembly attached to the jamb construction. No additional header supports are mandated by a larger opening width.

- ▶ **Static up to 50 PSF design wind-load**
- ▶ **Operational up to 10 PSF maximum wind-load**

OPTIONAL MATERIALS AND FINISHES

- ▶ Stainless steel - Type 304 in #4 finish
- ▶ CycleShield™ Powder Coating is available in more than 180 colors in addition to the standard Gray, Tan and White - *also available in CycleShield Ultra*
- ▶ Zinc-enriched, corrosion-resistant powder coating in Gray

UNIQUE FEATURES

1024 DRIVE AND CONTROL SYSTEM - Control panel features wall-mounted starter. PLC controller with variable-frequency drive featuring soft-start and soft-stop at both ends of limit travel. NEMA4 rated for harsh weather environments.

MONITORED PROTECTION, EVEN AT HIGH SPEEDS - The factory-mounted UL 325-2010 (NEMA 4C) compliant photo eye sensors allow for momentary contact operation, useful in parking garages and other high-use openings. Interruption of the photo eye beam before the door fully closes causes the door to immediately halt downward travel and reverse direction to return to the open position.

SAFETYGARD LIGHT CURTAIN TECHNOLOGY - The factory-mounted light curtain attaches easily to the guide assembly and extends approximately 6' high from the finished floor on both sides. If the door is cycling and an object passes through the curtain beams, the door will immediately halt downward travel and reverse direction to return to the open position.



CUSTOM-DESIGNED SOLUTIONS

Contact our experienced Architectural Design Support Team for help in customizing our products to fit your specific application.

 www.architectdoorhelp.com

800.294.4358 | cooksondoor.com

CornellCookson, LLC. is an ISO 9001:2015 registered company
9.2023

COOKSON Preferred door solutions.®