



Rolling Doors

COUNTER DOORS
INSTALLATION INSTRUCTIONS

COUNTER DOOR INSTALLATION INSTRUCTIONS

TABLE OF CONTENTS

PAGE#	DESCRIPTION	FIG#
2	Pre-Installation Instructions / Safety Check List	
3	Face Mounted Guide Installation	A1 / A2
4	Between Jamb Mounted Guide Installation	A3 / A4
5	Guide Installation (Cont.) / Fastener Chart	
6	Bracket Installation - W/Inside Tension Wheel	A5 / A6
7	Bracket Installation - W/Outside Tension Wheel	A7
8	Bracket Installation - Tubular Motor Operated Doors	A8
9	Bracket Installation - (Cont.)	A9
10	Wire Ring Installation & Top Slat Mounting Instructions	A10 / A11
11	Curtain Installation Instructions	A12 / A13
12	Counterbalancing Installation Instructions	A14
13	Counter Door Hood Mounting Details	A15 / A16

MOTOR OPERATORS

14	Mtr Oper Vert & Top Mtd LGJ Drive Bracket Detail	B1
15	Tubular Motor Operated Drive Brkt Detail	B2
16	Mtr Oper MGJ Drive Bracket Detail	B3
17	Wall Mounted Motor Operator	B4
18	Instructions for Setting Rotary Limit Switch	B5

SAFETY EDGES

19	Safety Edge Coil Cord/Cord Reel Installation Inside Door	C1
20	Safety Edge Coil Cord/Cord Reel Installation Outside Doors	C2

FREIGHT DAMAGE INSTRUCTIONS

*****IMPORTANT*****

Immediately upon delivery check condition of materials for visible concealed freight damage incurred in transit.

Under no condition should installation be made without authorization, as neither the carrier nor the Manufacturer will assume responsibility for labor costs involved in replacing damaged material that has been installed.

FOLLOW THE DIRECTIONS BELOW:

CONCEALED DAMAGE:

- (a) Must be inspected by carrier's representative within 15 days from date of delivery.
- (b) Consignee must obtain copy of Inspection Report.
- (c) Material should not be moved from point of delivery to other premises prior to discovery and/or reporting of damage.
- (d) Container and packing should be retained by consignee until inspection is made.

VISIBLE DAMAGE:

- (a) Must be inspected by carrier's representative within 15 days from date of delivery.
- (b) Consignee must obtain copy of Inspection Report.
- (c) Material should not be moved from point of delivery to other premises prior to discovery and/or reporting of damage.
- (d) Container and packing should be retained by consignee until inspection is made.

NOTE: IF DAMAGE IS CERTAIN, GOODS SHOULD NOT BE UNPACKED UNTIL INSPECTION IS MADE. IF DAMAGE IS UNCERTAIN, PACKAGES MAY BE OPENED BUT PACKING MATERIAL MUST BE SAVED UNTIL INSPECTION IS MADE.

INCOMPLETE DELIVERY:

- (a) Should be noted on delivery receipt.
- (b) Acknowledged by driver's signature.
- (c) Start tracing immediately.
- (d) Notify shipper.

RETURNING DAMAGED MATERIAL:

If damaged to the extent that it is necessary to return to the Manufacturer to be repaired, please do as follows:

- (a) Obtain permission to do so from the delivering carrier.
- (b) Route the return shipment via the identical carrier(s) involved in the original shipment.
- (c) Notify the Manufacturer when shipped.

PRE-INSTALLATION INSTRUCTIONS



**ONLY TRAINED DOOR SYSTEMS TECHNICIANS SHOULD
DROP TEST, RESET OR PERFORM MAINTENANCE**



**READ AND FOLLOW THESE INSTRUCTIONS THOROUGHLY - THE COOKSON
COMPANY WILL NOT BE HELD RESPONSIBLE FOR ANY CHARGES INCURRED
THROUGH MISSING PARTS, OPERATION, OR DAMAGE- DUE TO IMPROPERLY
INSTALLED DOOR ASSEMBLIES**

- 1) If you have received more than one door, you will find that all major parts and pieces for any one door are marked with corresponding numbers; therefore, a complete door should be composed of parts bearing the same numbers and letters.

DO NOT INTERCHANGE PARTS FROM ONE DOOR TO ANOTHER!!!

- 2) Before installing the door see that all component markings agree.
- 3) Before attempting installation of the door and, specifically, before leaving the jobsite make certain you have read and adhered to the attached "Safety Check List".
- 4) Should there be any discrepancies in the job conditions or manufactured materials, contact The Cookson Company in writing or by calling 1-800-294-4358 for Western U.S. and Canada or 1-800-390-8590 for Eastern U.S. and Canada. If door was purchased by a Cookson Distributor and sold to another party they should contact the Distributor for Warranty or Repair parts.

SAFETY CHECK LIST

**IN ORDER FOR YOU TO ASSURE YOUR CUSTOMER THAT THIS DOOR HAS BEEN
INSTALLED PROPERLY AND IN A SAFE MANNER, WE ASK THAT YOU CHECK THE
FOLLOWING BEFORE LEAVING THE JOBSITE.**

- 1) Make certain that the proper amount of tension has been applied to the torsion springs, in order to properly counterbalance the weight of the curtain.
- 2) Assure yourself that the tension wheel is securely fastened in place.
- 3) Assure yourself that sprockets or gears requiring keys have the correct keys installed and drive shaft sprockets or gears are retained by cotter pins.
- 4) Recheck the setscrews (One over key - the other located at 45° from key) in each sprocket or gear for tightness.
- 5) Check all fasteners holding guides to building structures.
- 6) Check all fasteners used in assembling door components.
- 7) Instruct owner or his/her representative in the proper method of operating this door.

COUNTER DOORS

FACE MOUNTED GUIDE INSTALLATION

NOTE: PLEASE READ CAREFULLY BEFORE ATTEMPTING ASSEMBLY.

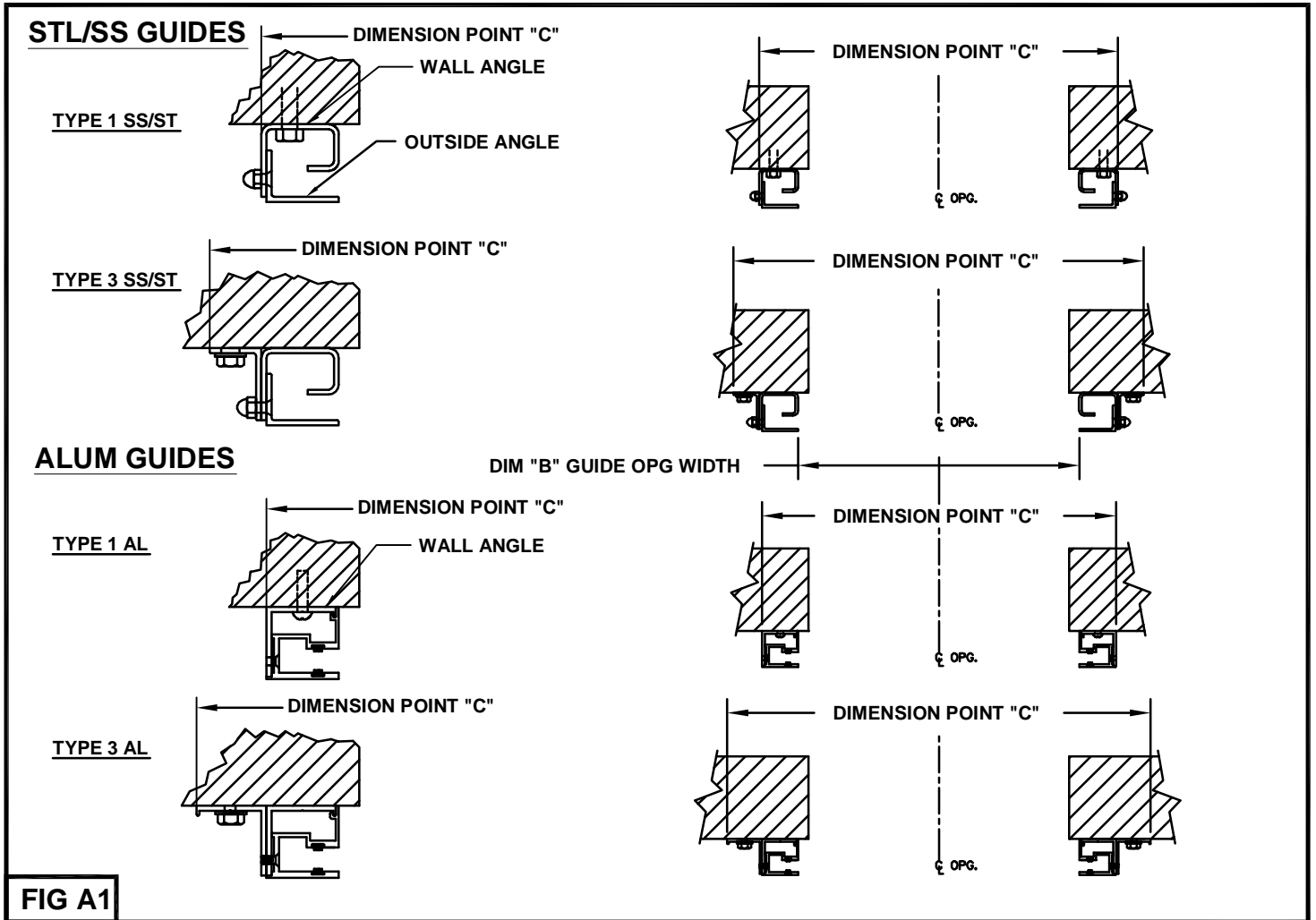

FIG A1

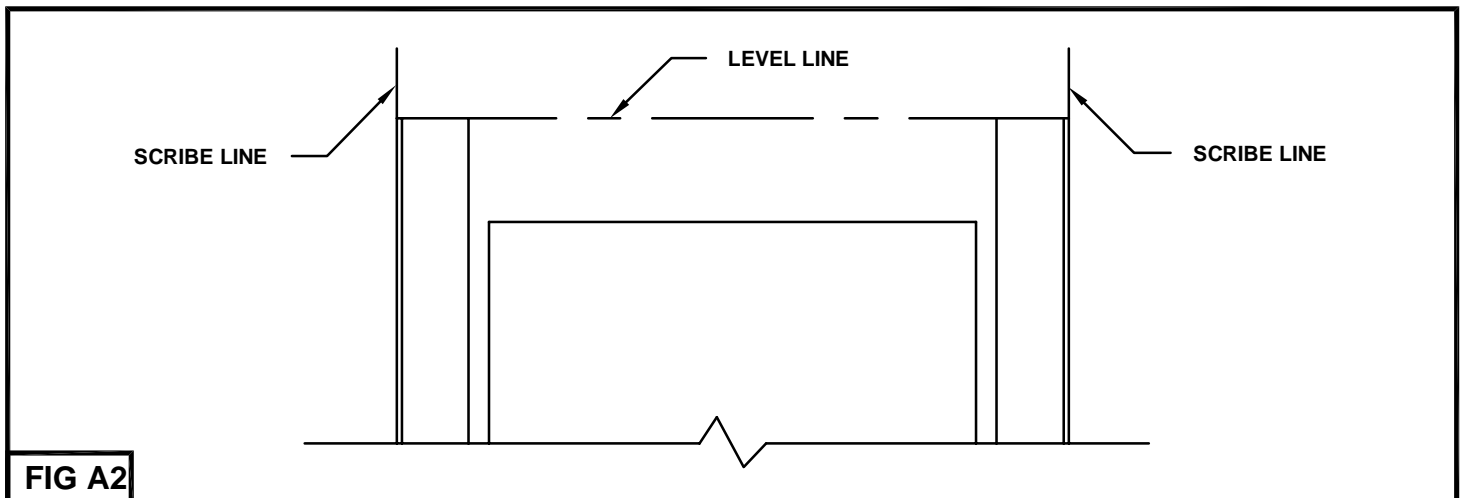

FIG A2

1) Adjust lock block if necessary to ensure proper lock engagement.

COUNTER DOORS

BETWEEN JAMB MTD GUIDE INSTALLATION

NOTE: PLEASE READ CAREFULLY BEFORE ATTEMPTING ASSEMBLY.

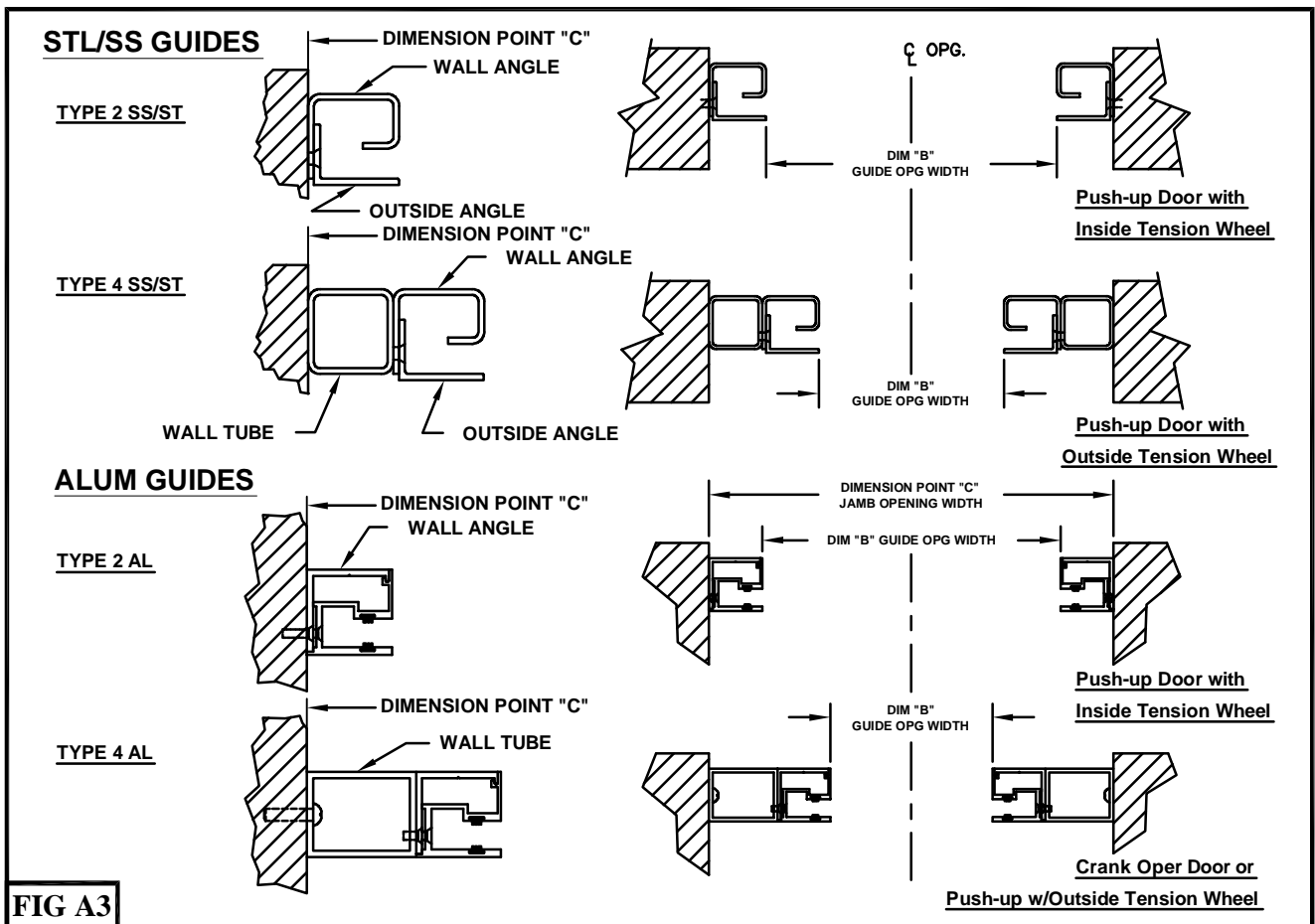

FIG A3

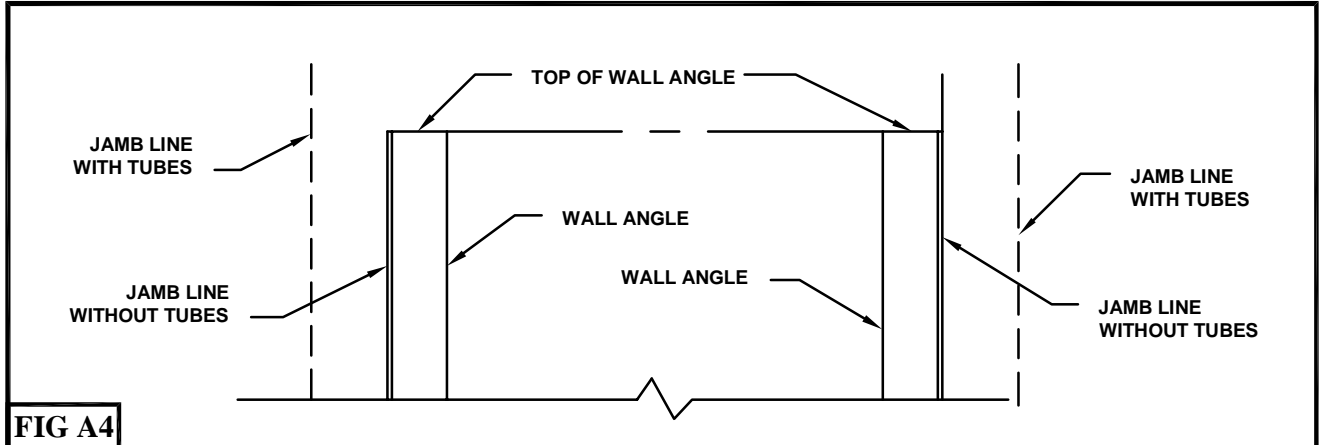

FIG A4

- 1) Locate guide dimension point for both left and right jamb. Measurement between dimension points must equal dimension "C".
- 2) For typical installation for Type 1 and 3 (See FIG. A1) guide assemblies, Dimension point "C" is centered around jamb opening - (if side room permits) - if there are questions check job construction drawings (if available).
- 3) Check the Guide opening measurement. Locate a mark on the floor at the tip of each guide and measure. Guide measurement must equal Dim "B". (See FIG 1 & 3) **THIS IS CRITICAL** If guide opening does not equal Dim "B", **STOP** and redo steps 1 and 2.
- 4) Scribe a plumb line on the wall at dimension points.
- 5) Place the guides against the scribed line and with the tops of guides level, mark the location of the mounting holes. NOTE: Guide types 1, 2 & 4 have to be disassembled.
- 6) Drill mounting holes for wall fasteners and mount the guides. (See Table on PG 5 for fastener type) Reassemble guides if necessary.
- 7) Adjust lock block if necessary to ensure proper lock engagement.

3) Now drill the holes in the jambs as follows:

FASTENER CHART

STEEL GUIDES:

Wood Jamb:

W/Wall Tube

Pre-drill the holes with a 3/16" diameter drill for mounting the guides to the jamb with 3/8" diameter lag screws.

W/O Wall Tube

Pre-drill the holes with a 1/8" diameter drill for mounting the guides to the jamb with #12 wood screws.

Concrete Jamb:

W/Wall Tube

Drill the concrete with a 3/8" diameter star drill, 1-5/8" deep, and insert 3/8" wedge anchors.

W/O Wall Tube

Drill the concrete with a 5/16" diameter star drill, 1-1/2" deep, and insert #12 plastic shields.

Steel Jamb:

W/Wall Tube

Drill the steel jamb with a 5/16" drill and tap the holes with a 3/8-16 NC tap.

W/O Wall Tube

Drill the steel jamb with a #7 drill and tap the holes with a 1/4-20 NC tap.

Hollow Metal Jamb:

Use 1/4" self-drilling and tapping screws.

Hollow Ceramic Tile Jamb:

Drill 7/16" diameter holes to receive 1/4-20 Type "L" Wall Grip.

ALUMINUM GUIDES:

Wood Jamb:

Pre-drill the holes with a 1/8" diameter drill for mounting the guides to the jamb with #12 wood screws.

Concrete Jamb:

Drill the concrete with a 5/16" diameter star drill, 1-1/2" deep, and insert #12 plastic shields.

Steel Jamb:

Drill the steel jamb with a #7 drill and tap the holes with a 1/4-20 NC tap.

Hollow Metal Jamb:

Use 1/4" self-drilling and tapping screws.

Hollow Ceramic Tile Jamb:

Drill 7/16" diameter holes to receive 1/4-20 Type "L" Wall Grip.

4) Examine the end of the 1" round stationary shaft on the door's barrel. This is called the drive shaft.

BRACKET INSTALLATION WITH INSIDE TENSION WHEEL

When looking at a completely assembled door from the direction as shown in Fig. 5.....

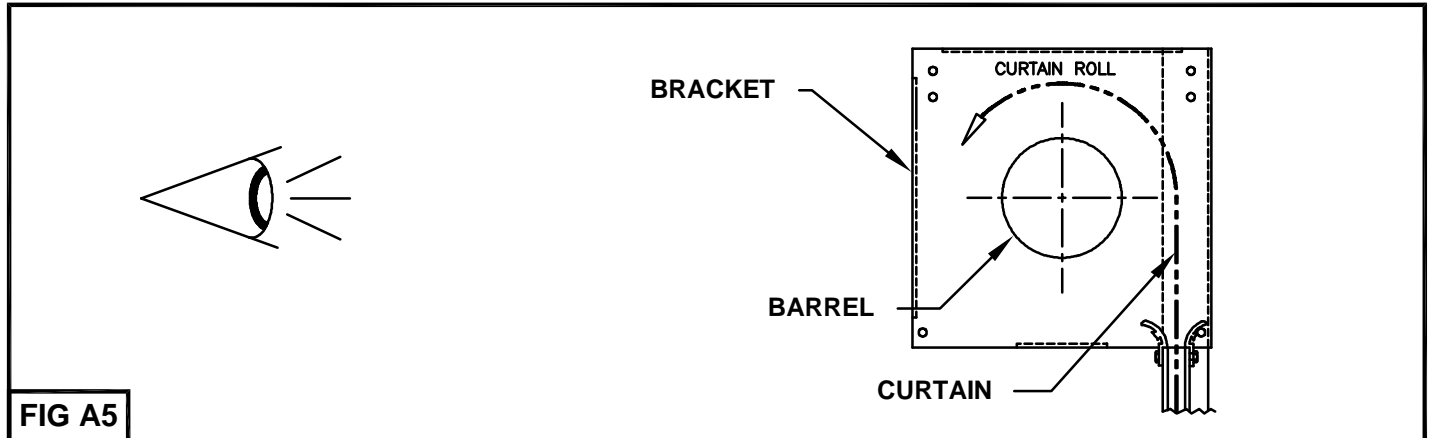

the barrel and bracket assembly should appear as below in Fig. 6 if an inside tension wheel is supplied. If an outside tension wheel is supplied, see Fig. 7 on Page 7.

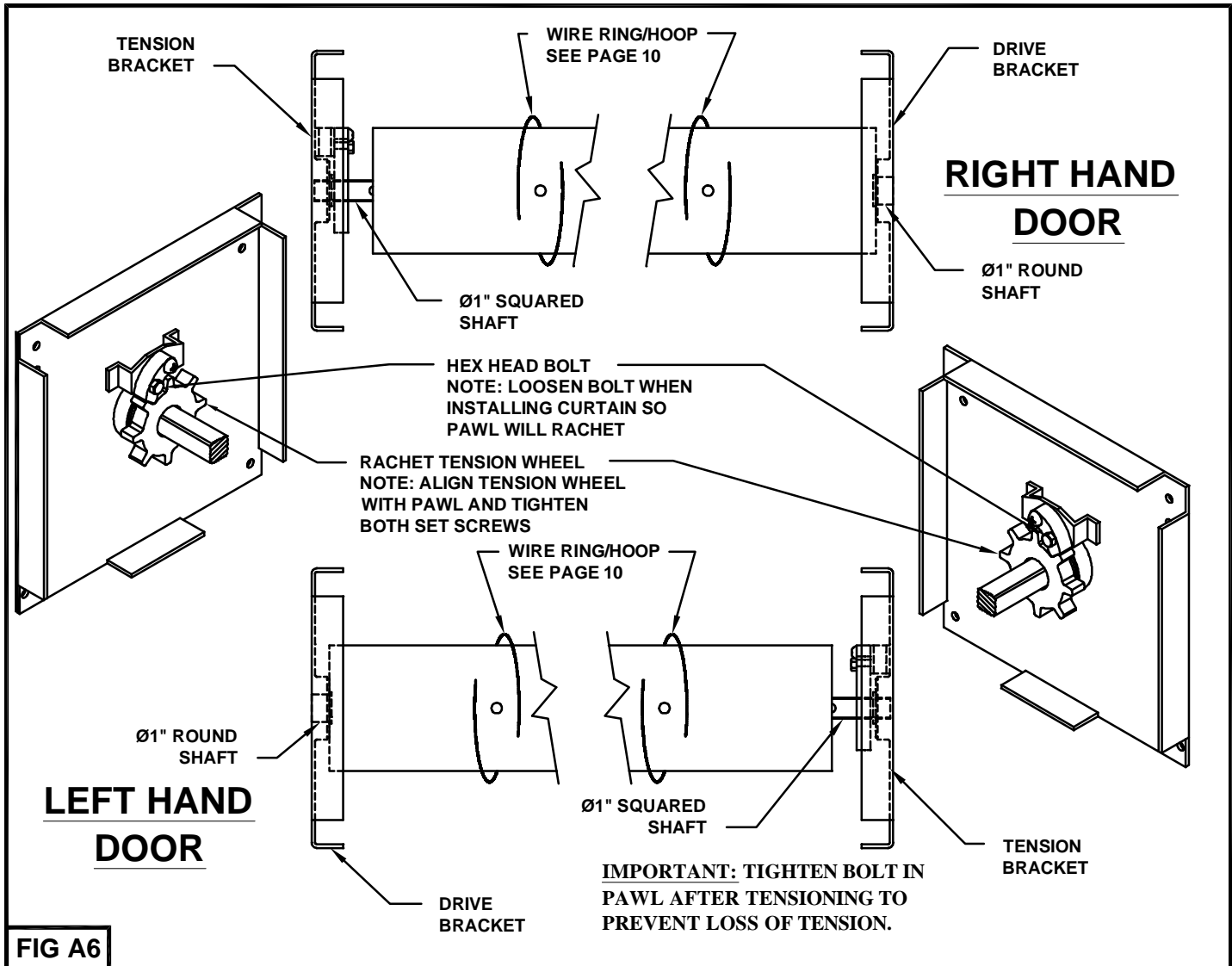

Extended drive shaft has been provided. If wall or an obstruction is in contact with the shaft, cut shaft off flush to outside of bracket plate. Minimum shaft length required is 1-1/8".

BRACKET INSTALLATION WITH OUTSIDE TENSION WHEEL

When looking at a completely assembled door from the direction as shown in Fig. A5.....
the barrel and bracket assembly should appear as below in Fig. A7.

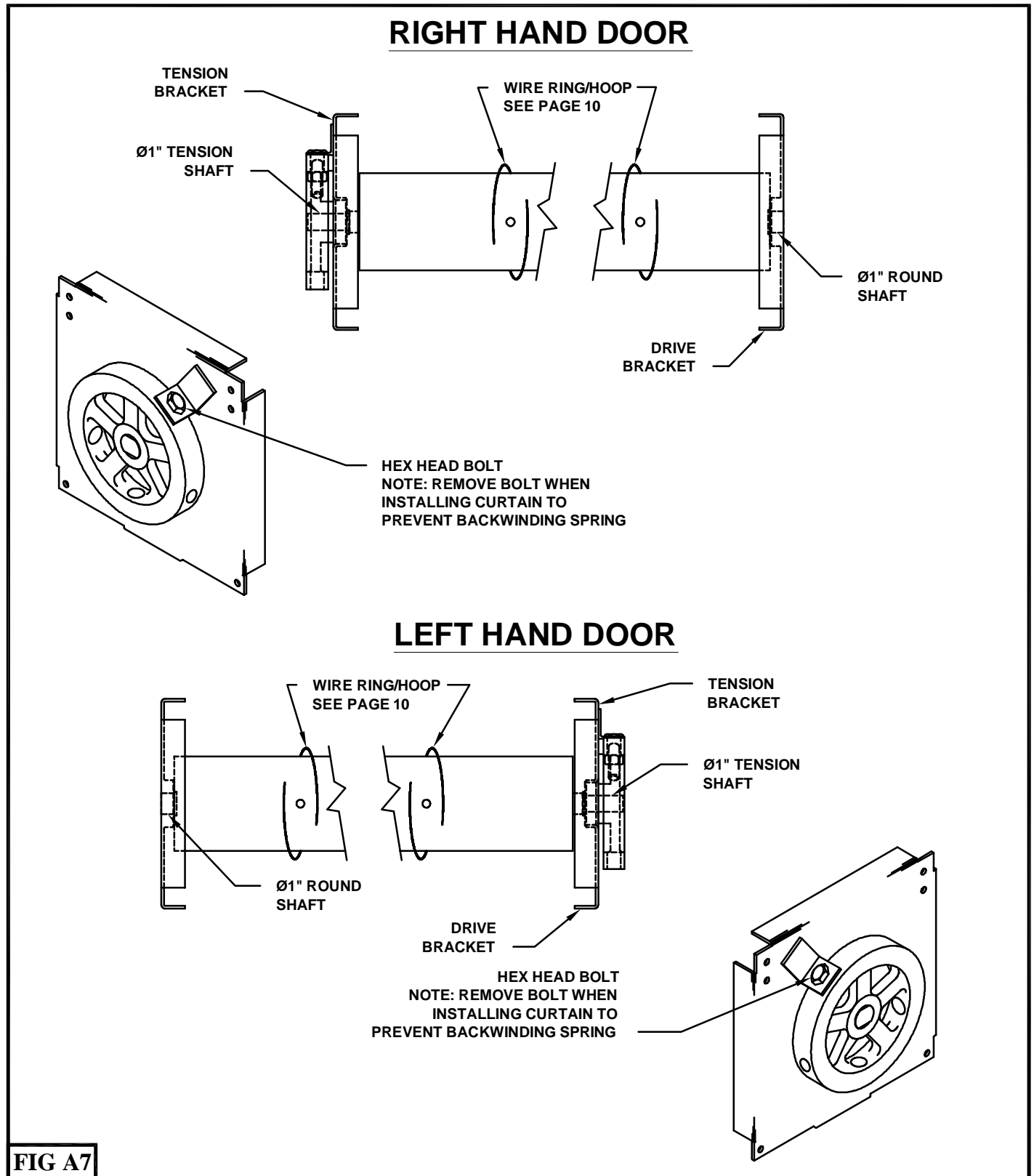

Extended drive shaft has been provided. If wall or an obstruction is in contact with the shaft, cut shaft off flush to outside of bracket plate. Minimum shaft length required is 1-1/8".

BRACKET INSTALLATION FOR TUBULAR MOTOR OPERATED DOORS

When looking at a completely assembled door from the direction as shown in Fig. A5.....
the barrel and bracket assembly should appear as below in Fig. A8.

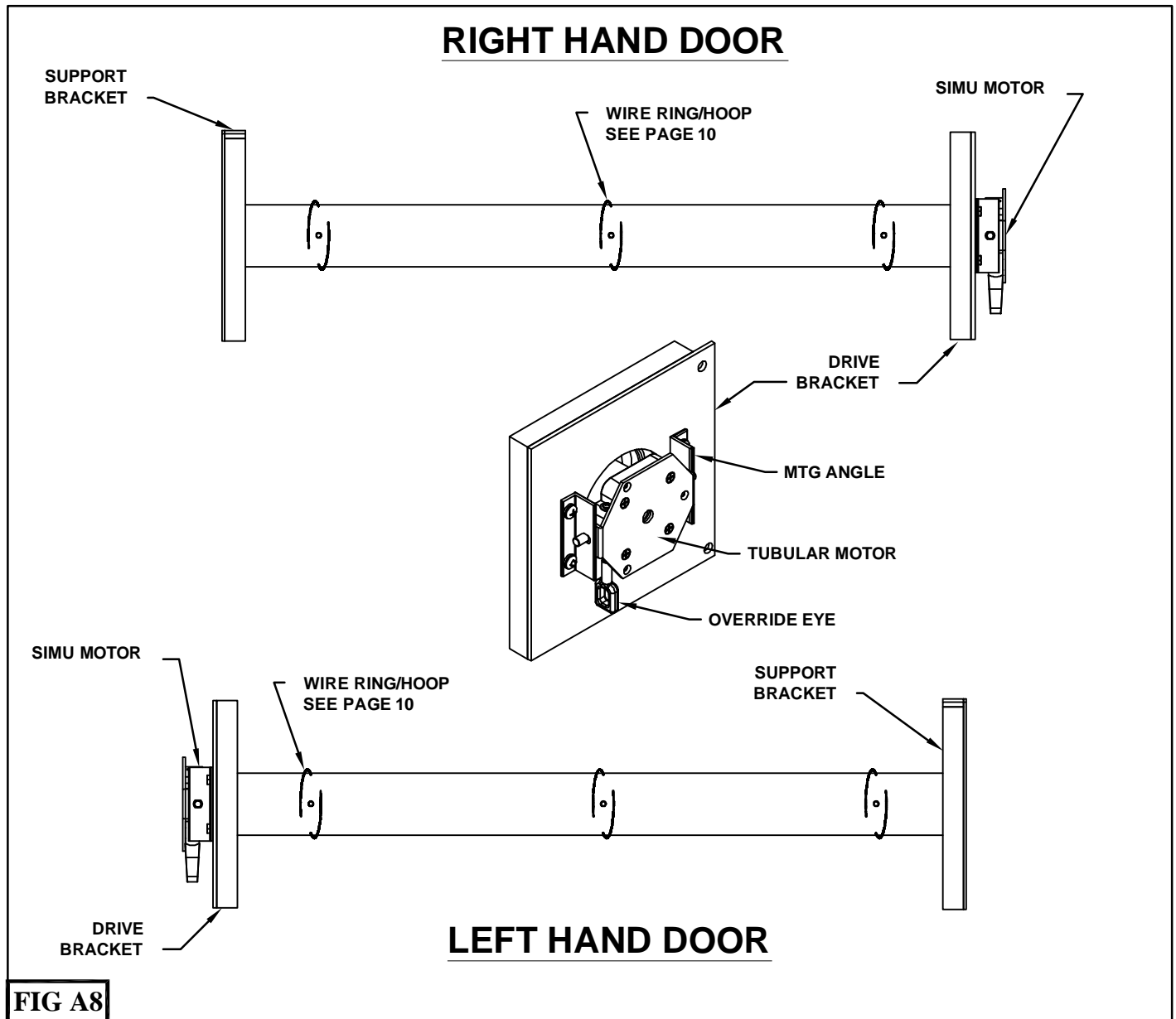

5) To assemble the brackets to the barrel as shown previously, place the barrel on the floor below the opening in the correct position it takes when actually mounted. **MAKE SURE THAT THE WIRE RINGS HAVE BEEN INSTALLED.**

(see page 10)

INSIDE TENSION WHEEL INSTRUCTIONS:

Place the ratchet tension wheel on the tension shaft. Now install both the drive bracket and tension bracket on their respective shafts. Note: the bracket **WITHOUT** the pawl above the hub is to be placed on the end of the barrel that has the 1" round shaft. The assembly should now appear as shown on page 6 (Fig. A6).

OUTSIDE TENSION WHEEL INSTRUCTIONS:

Install both the drive bracket and the tension bracket on their respective shafts. Note: the drive bracket is to be placed on the 1" round shaft without the cope. The assembly should now appear as shown on page 7 (Fig. A7).

TUBULAR MOTOR INSTRUCTIONS

Prior to installing the brackets onto the barrel, install the wire rings/hoops. See sheet 10 for instructions. Install the support bracket on the 1" support shaft. On the drive side attach the motor to the drive bracket. The motor should come installed in the barrel. Remove the motor mounting angles attached to the drive bracket. Slide the motor through the hole in the drive bracket. Attach the motor mounting plate to the motor using the (4) screws and nuts provided. Attach the motor mounting angles to the bracket plate. The assembly should now appear as shown on page 8 (Fig. A8).

- 6) Remove the guide stops from the guides. Now raise the complete assembly into position at the head of the opening and bolt the brackets to the wall angles and jamba as shown in Fig A9 below.

CAUTION: EACH ASSEMBLY IS HANDED RIGHT OR LEFT. SEVERE SPRING DAMAGE AND PRODUCT FAILURE MAY OCCUR IF DOORS ARE NOT MOUNTED WITH THE CORRECT HANDING.

DRILLING SCHEDULE FOR MOUNTING BRACKET AND WALL ANGLE

ALUMINUM GUIDES

WOOD: Pre-drill holes with 5/32" drill for #20 RHWS.

MASONRY: Pre-drill holes with 7/16" drill for #20 Shield.

STEEL: Drill W/#F drill and tap with 5/16-18 N.C. Tap.

STEEL/SS GUIDES

Pre-drill holes with 5/32" drill for #20 RHWS.

Pre-drill holes with 7/16" drill for #20 Shield.

Drill W/5/16 drill and tap with 3/8-16 N.C. Tap.

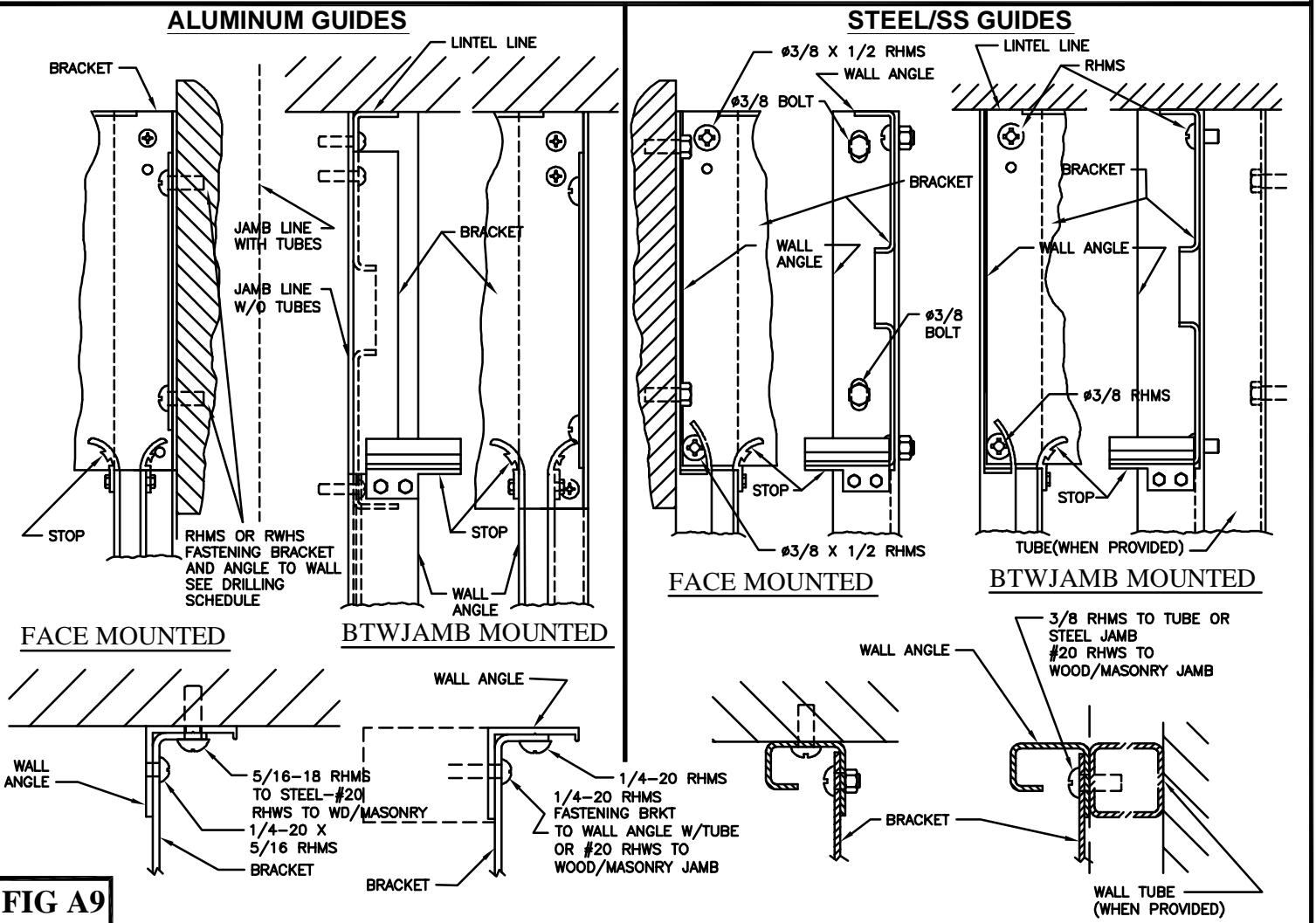
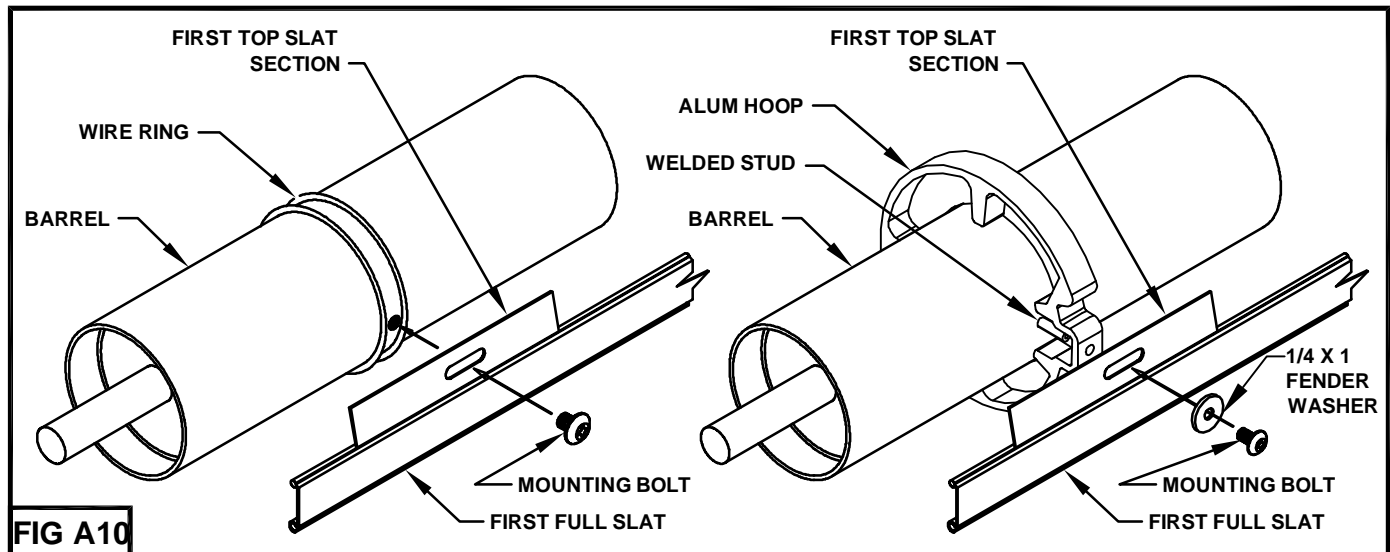

FIG A9

WIRE RING / HOOP INSTALLATION AND TOP SLAT MOUNTING INSTRUCTIONS

PRIOR TO INSTALLING THE BRACKETS ONTO THE BARREL....

- 1) Slide the wire rings / hoops over the end of the barrel and align them with the slat mounting screw hole or welded stud as shown in Fig. A9 below.
- 2) Install the barrel and the curtain as per their installation instructions.



CRANK GEARBOX ASSEMBLY INSTALLATION INSTRUCTIONS

- 1) The worm gear and gear box are shipped already mounted to the bracket.
- 2) Unbolt the gear box and assemble it over the drive shaft as shown below in Fig. A11. On between jamb doors, this is usually done easiest prior to assembling the brackets to the guides.

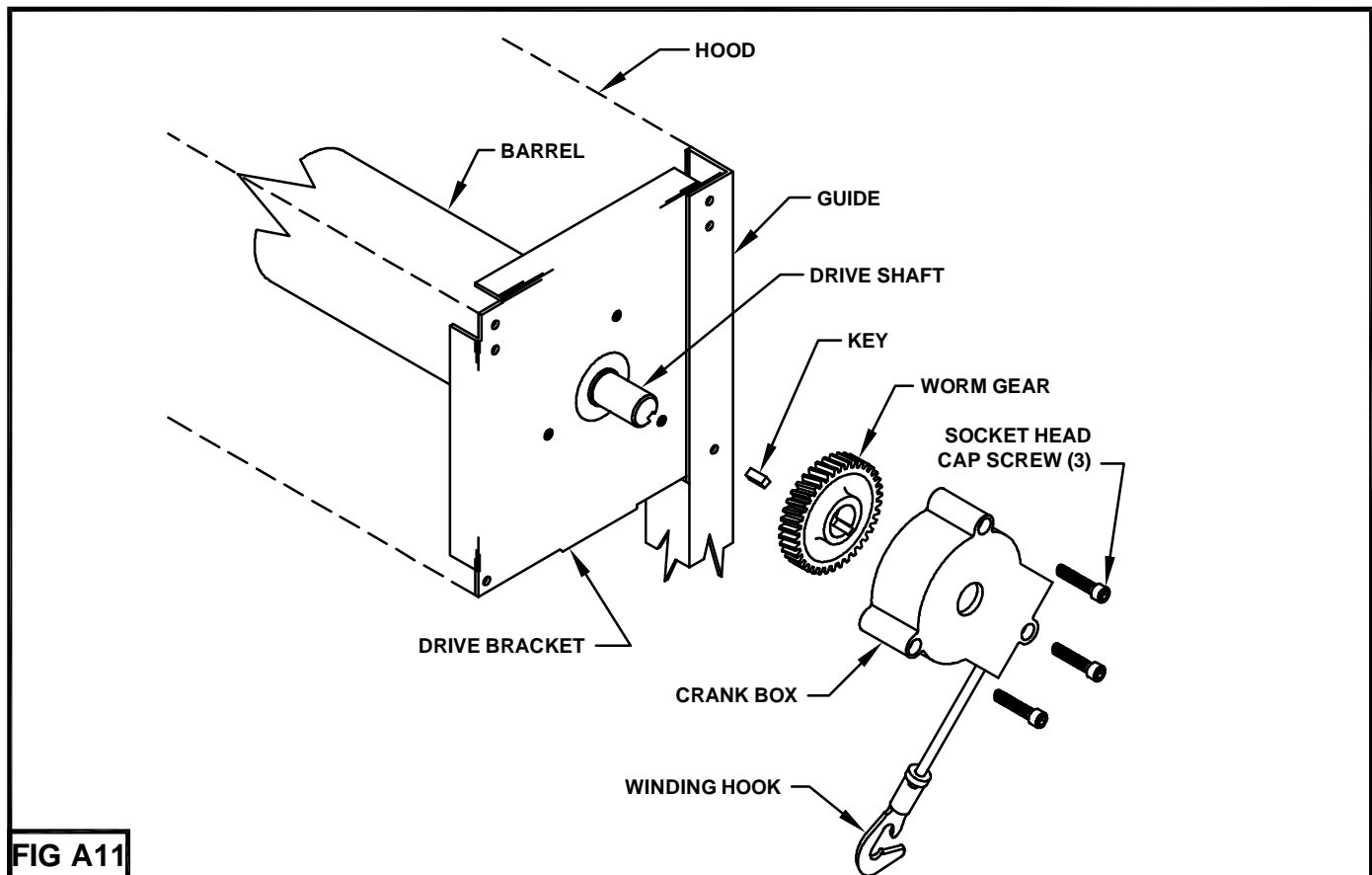

CURTAIN

INSTALLATION INSTRUCTIONS

- 1) With the curtain rolled up (as shipped from the factory) place it in slings below the barrel as shown below in Fig. A12. The slings may be made from soft cotton clothesline or other material that will not scratch the anodized finish.

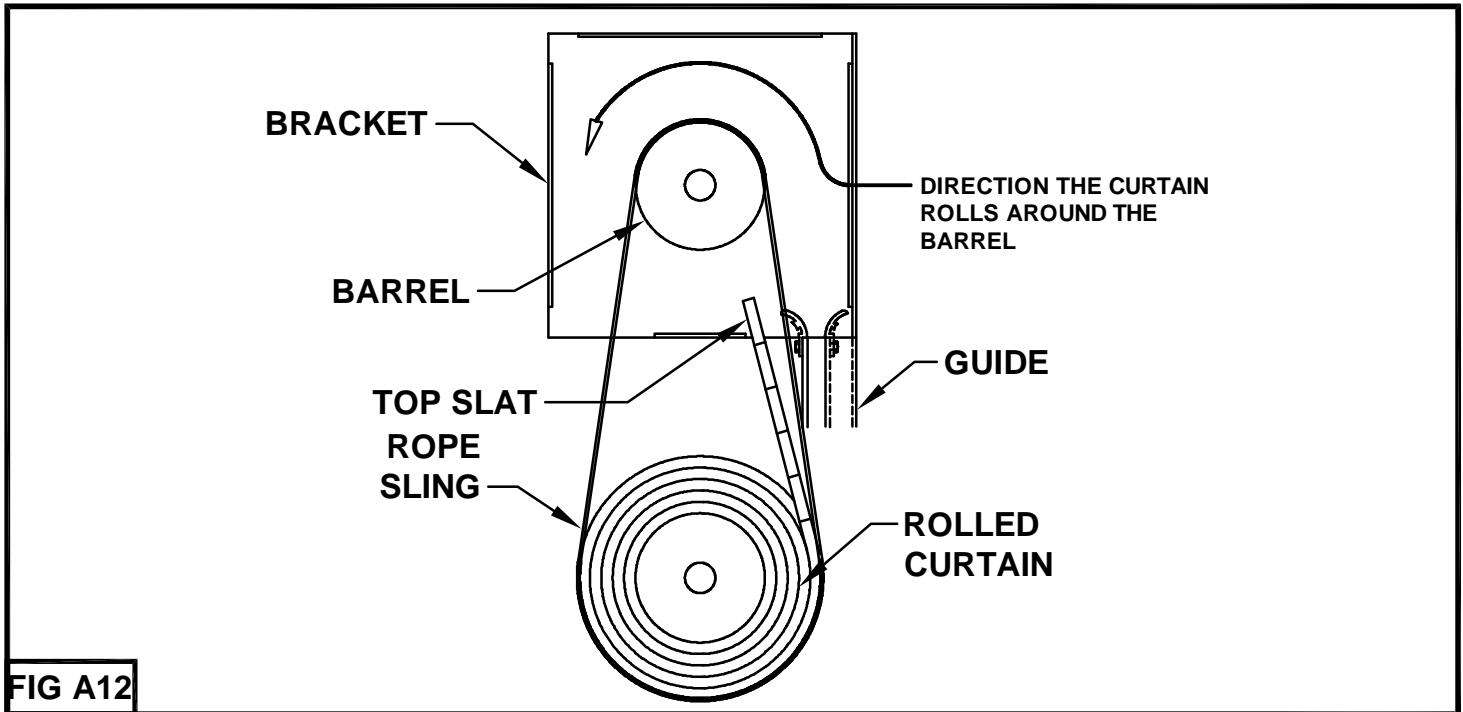

FIG A12

IMPORTANT: ALL TENSION WHEELS MUST BE FREE TO ROTATE DURING THE INSTALLATION OF THE CURTAIN. BACK OUT THE HEX HEAD BOLT ON THE INSIDE TENSION WHEEL PAWL SO THAT THE PAWL WILL RACHET. FAILURE TO DO THIS WILL BACKWIND THE SPRING AND CAUSE DAMAGE. Pull the top slat around the barrel and line up the slots in the slat with the holes in the barrel. The clearance between the end of the curtain and the brackets must be the same on each end. Bolt the curtain to the barrel with the screws provided.

CAUTION: THE USE OF LONGER SCREWS THAN PROVIDED WILL INTERFERE WITH AND DAMAGE THE OPERATION OF THE TORSION SPRING IN THE BARREL (SEE PAGE 12).

If hoops are used: Line up the hoops according to the punched holes in the top slat, being sure that the edges of the curtain are equidistant from each bracket, and so that the curtain is straight on the bracket. Bolt the curtain to the hoops.

- 2) Now roll the curtain around the barrel with the rope slings in place. When the curtain is completely wrapped around the barrel, feed the bottom bar into the guide grooves. Slowly lower the curtain all the way down so that the opening is now closed and reinstall the stops onto the guides.

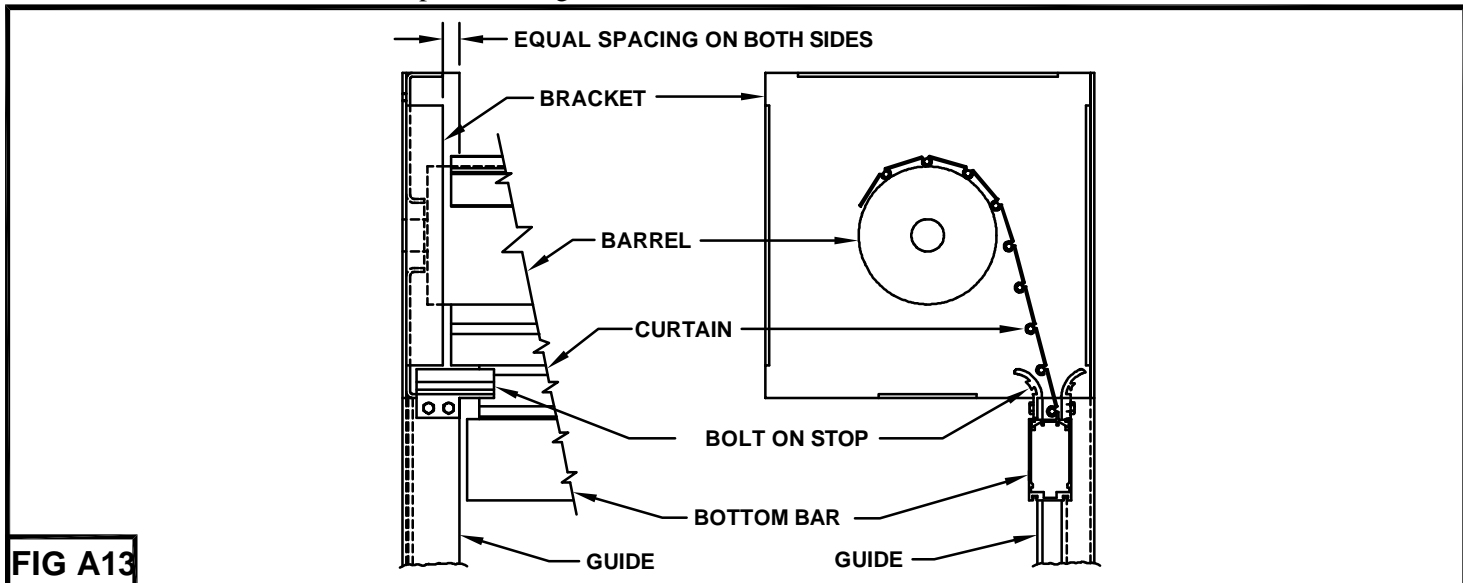

FIG A13

COUNTERBALANCING INSTALLATION

Inside Tension Wheel:

- 1) With the barrel and the curtain set in the proper location, make sure that the tension wheel set screws are tightened to the barrel shaft. Apply tension to the counterbalancing spring with the door in the closed position as follows:
Engage an 8" adjustable wrench onto the squared shaft and rotate the wheel in the direction that the barrel must rotate to roll up the curtain onto the barrel. See the Installation Information Sheet for the range that the tension should be set at. Be sure before removing the wrench each time that the pawl is engaged in the tension wheel. After the tension is properly set, lock down the tension pawl with the hex head machine bolt in the pawl.

Outside Tension Wheel:

- 2) Install the outside tension wheel onto the coped shaft. Apply tension to the counterbalancing spring with the door in the open position as follows:
See the Installation Information Sheet for the proper amount of tension to apply. Apply tension to the counterbalancing spring in the same direction the curtain rolls onto the barrel. Install the locking bolt after the tension has been applied. The operation of the door should be such that the door will stay at the head and at the floor.

CAUTION: UNDER NO CIRCUMSTANCES SHOULD MORE THAN ONE FULL TURN BE ADDED OVER THAT WHICH IS REQUIRED TO HOLD THE CURTAIN'S BOTTOM BAR AT THE GUIDE STOPS.

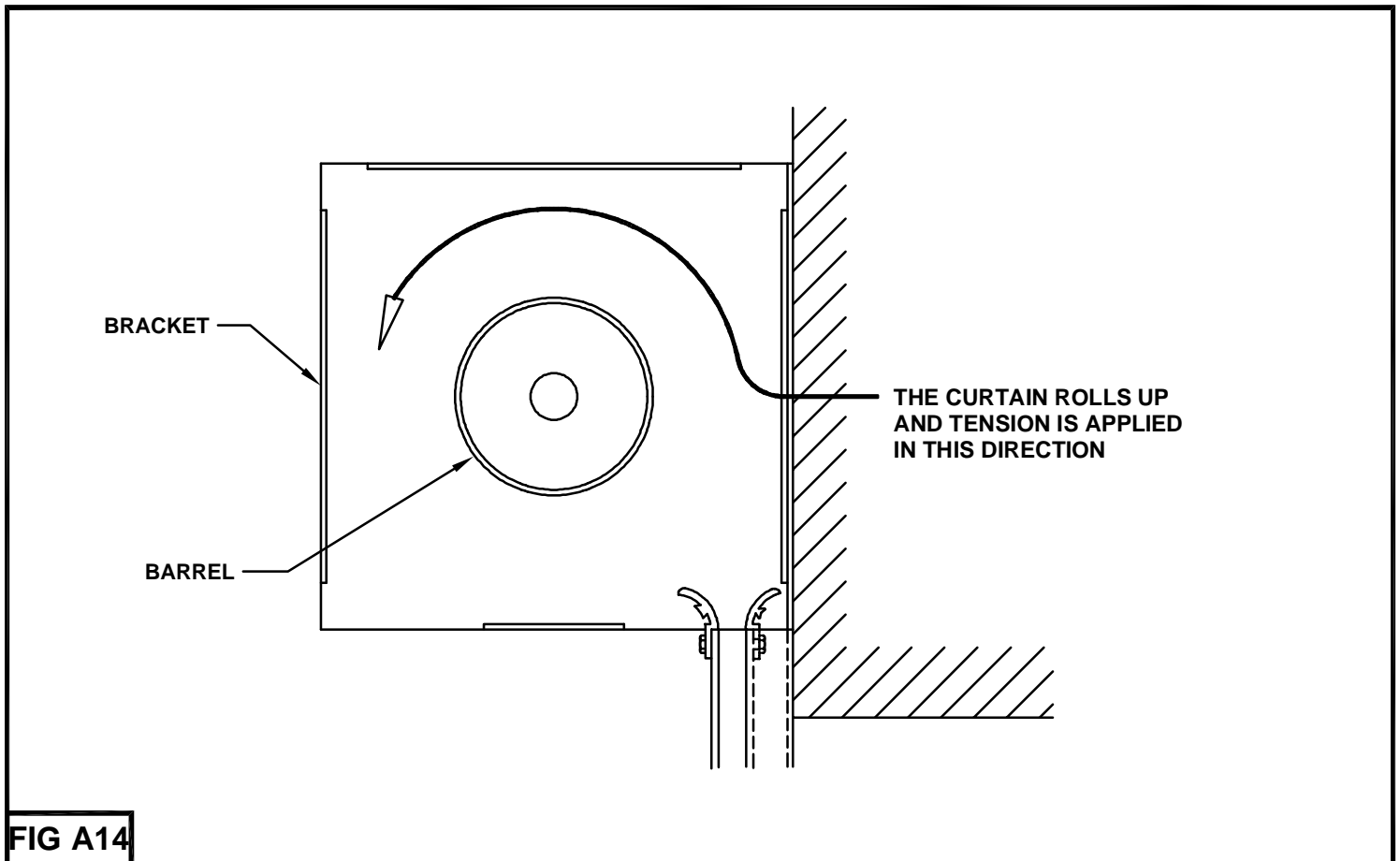

To assemble the hood, soffit and flashing, see the following page for details.

COUNTER DOOR HOOD MOUNTING DETAILS

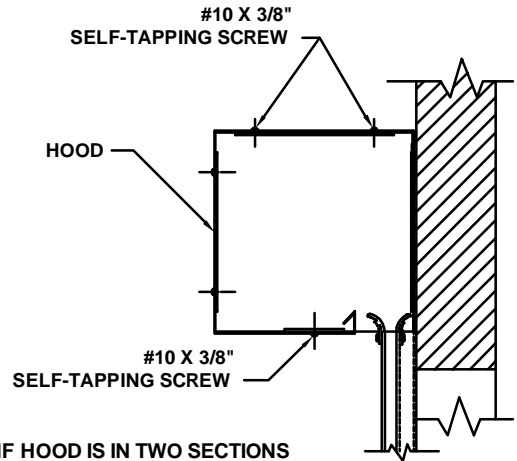
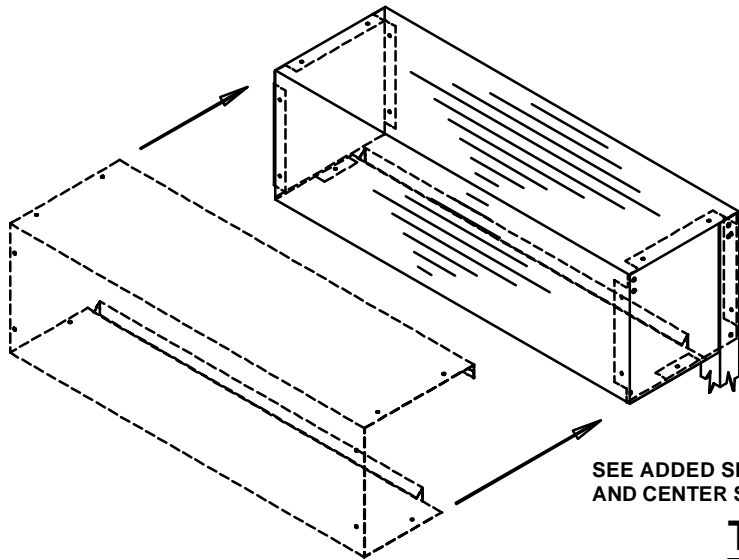

SEE ADDED SHEET IF HOOD IS IN TWO SECTIONS
AND CENTER SUPPORT IS REQUIRED

TYPE A FACE MOUNTED HOOD

FIG A15

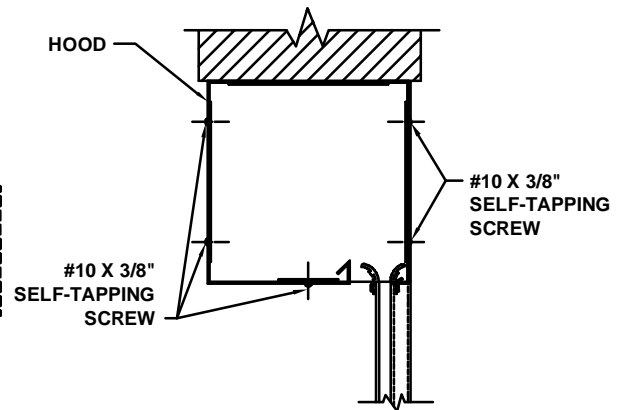
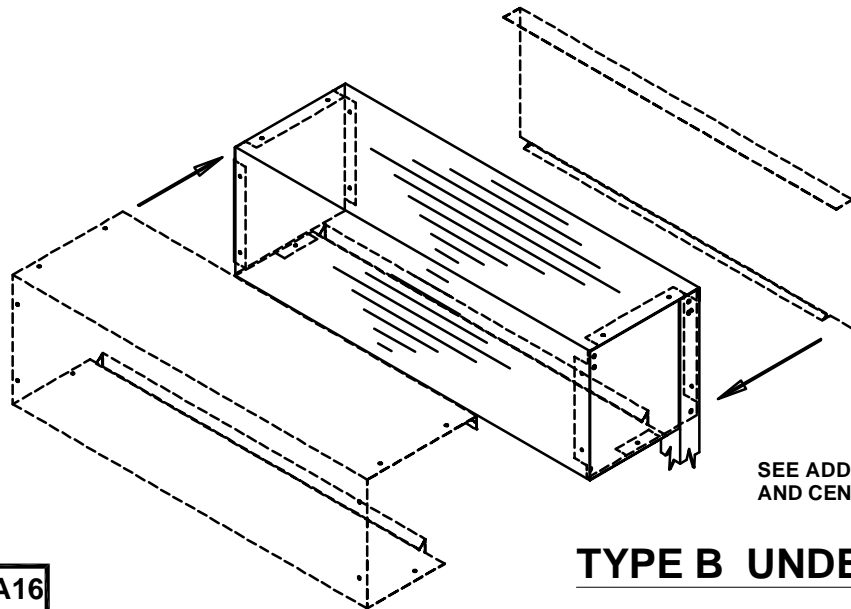

SEE ADDED SHEET IF HOOD IS IN TWO SECTIONS
AND CENTER SUPPORT IS REQUIRED

TYPE B UNDER LINTEL MOUNTED HOOD

FIG A16

MOTOR OPERATED DRIVE BRACKET DETAIL

VERTICAL & TOP MOUNTED MODEL LGJ

A) ASSEMBLE THE MOTOR OPERATOR ONTO THE DRIVE BRACKET ASSEMBLY, AND THE DRIVE BRACKET/MOTOR OPERATOR ASSEMBLY ONTO THE BARREL SHAFT AS SHOWN BELOW.

LEFT-HAND VERTICAL

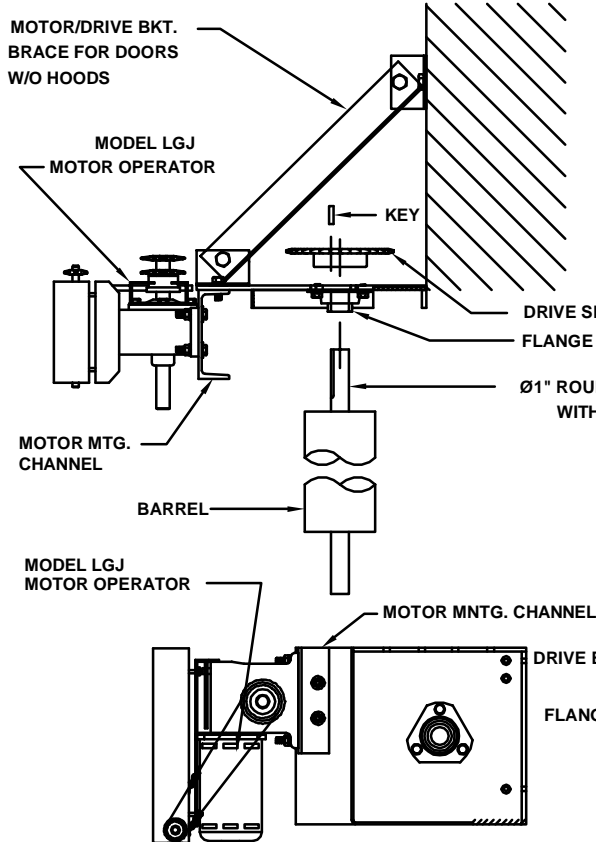

RIGHT-HAND VERTICAL

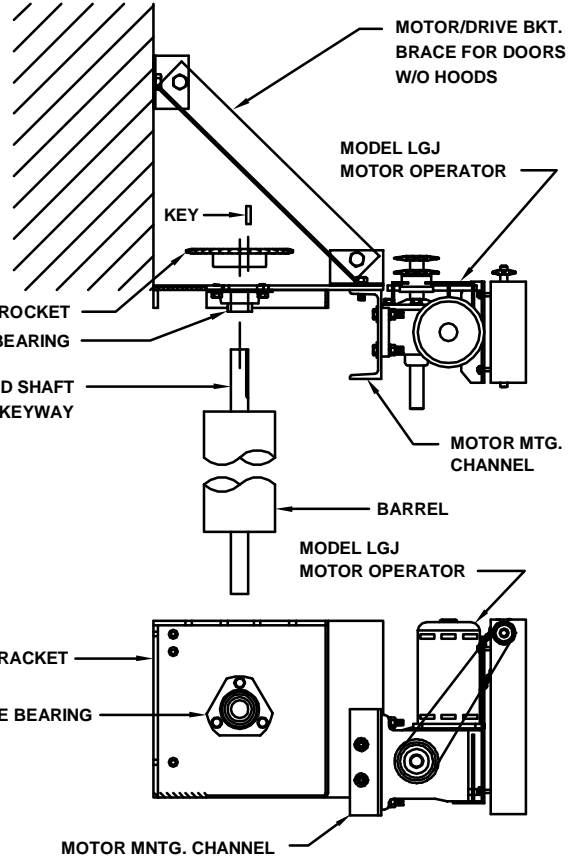

1) AFTER DOOR IS INSTALLED AND BRACKET PLATES ARE PERPENDICULAR TO WALL, ATTACH MOTOR/BKT BRACE TO BRACKET AND WALL AS SHOWN.

2) MAKE SURE THAT BOLTS ARE TIGHT AND AND BRACKET PLATE IS PERPENDICULAR TO WALL.

LEFT-HAND TOP MTD

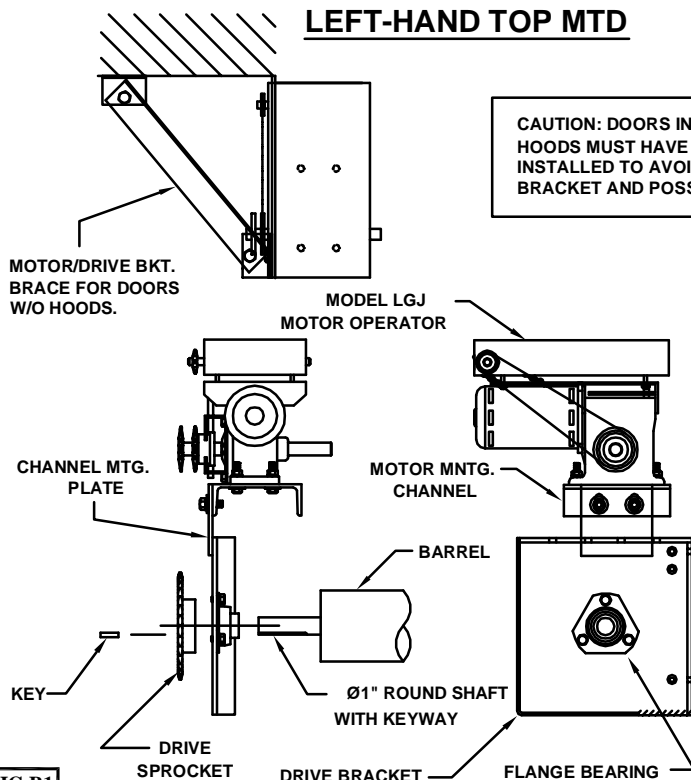

RIGHT-HAND TOP MTD

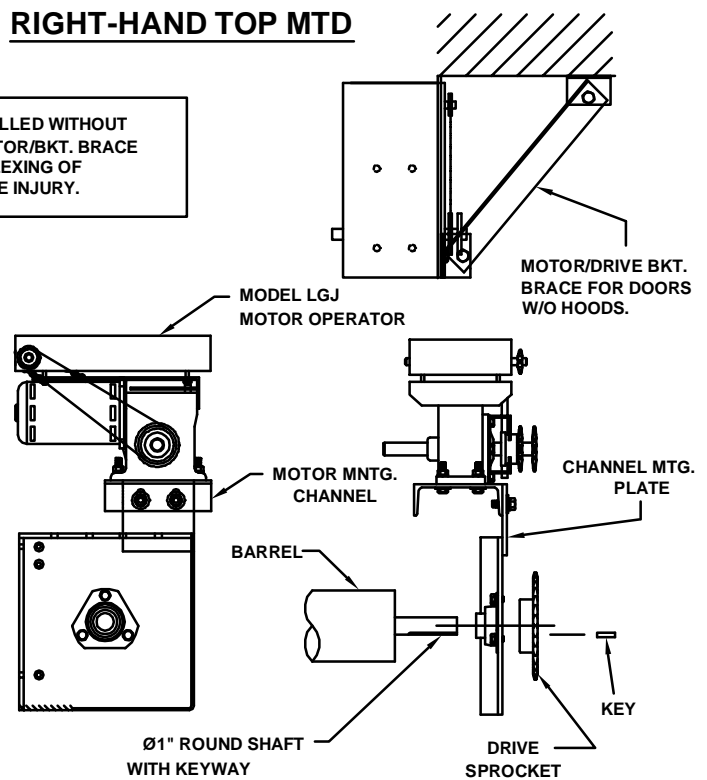
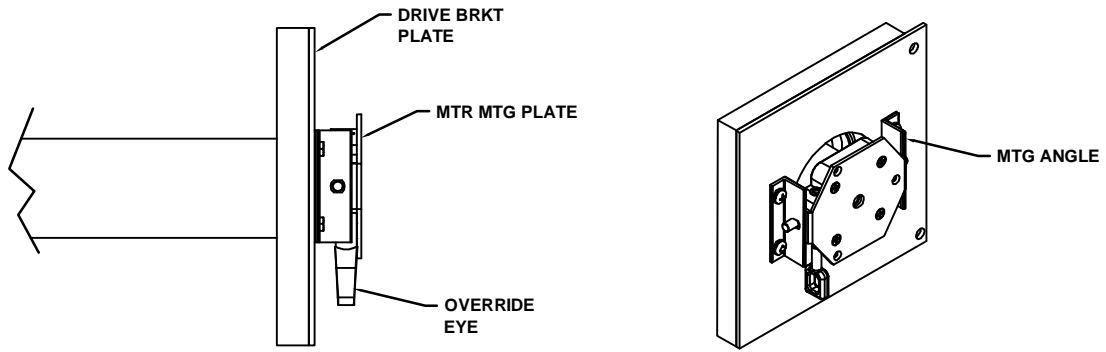

FIG B1

TUBULAR MOTOR OPERATED
DRIVE BRACKET DETAIL

RIGHT-HAND MOTOR



LEFT-HAND MOTOR

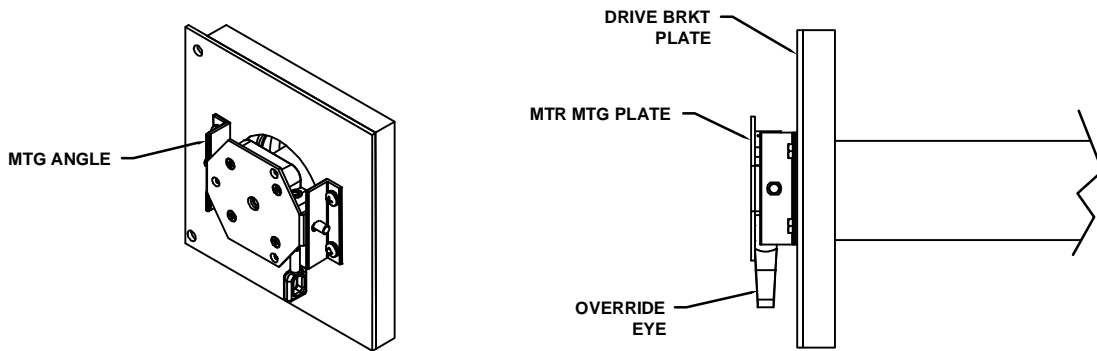
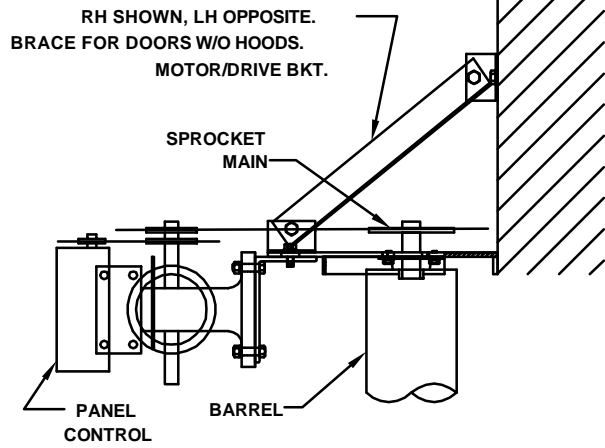

FIG B2

MOTOR OPERATED DRIVE BRACKET DETAIL VERTICAL & TOP MOUNTED MGJ

LEFT-HAND VERTICAL



RIGHT-HAND VERTICAL

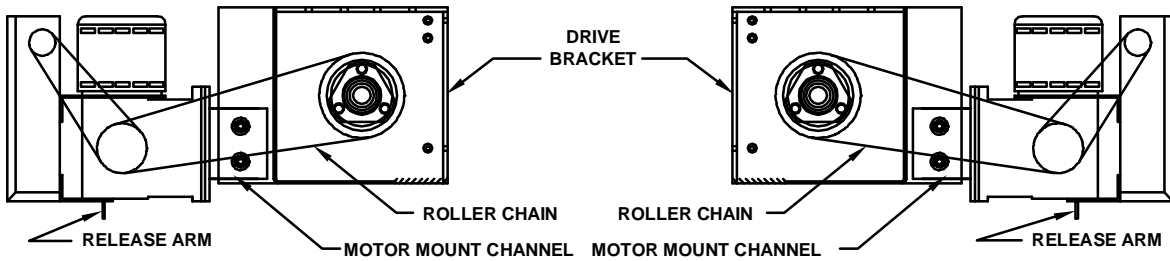
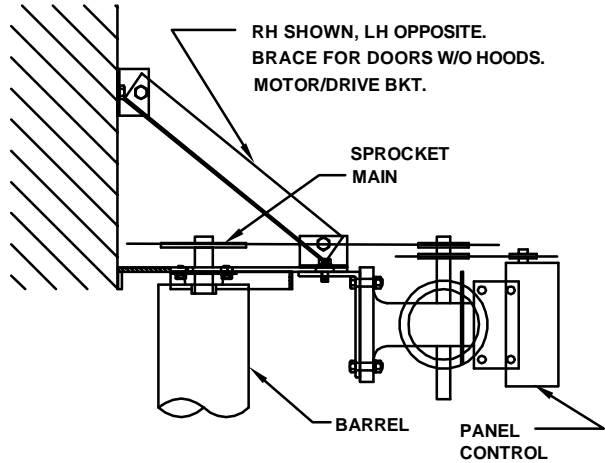

- 1) AFTER DOOR IS INSTALLED AND BRACKET PLATES ARE PERPENDICULAR TO WALL, ATTACH MOTOR/BKT BRACE TO BRACKET AND WALL AS SHOWN.
- 2) MAKE SURE THAT BOLTS ARE TIGHT AND AND BRACKET PLATE IS PERPENDICULAR TO WALL.

CAUTION: DOORS INSTALLED WITHOUT HOODS MUST HAVE MOTOR/BKT. BRACE INSTALLED TO AVOID FLEXING OF BRACKET AND POSSIBLE INJURY.

LEFT-HAND TOP MTD

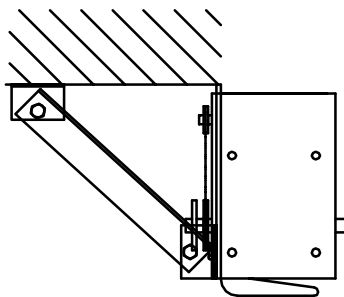

RIGHT-HAND TOP MTD

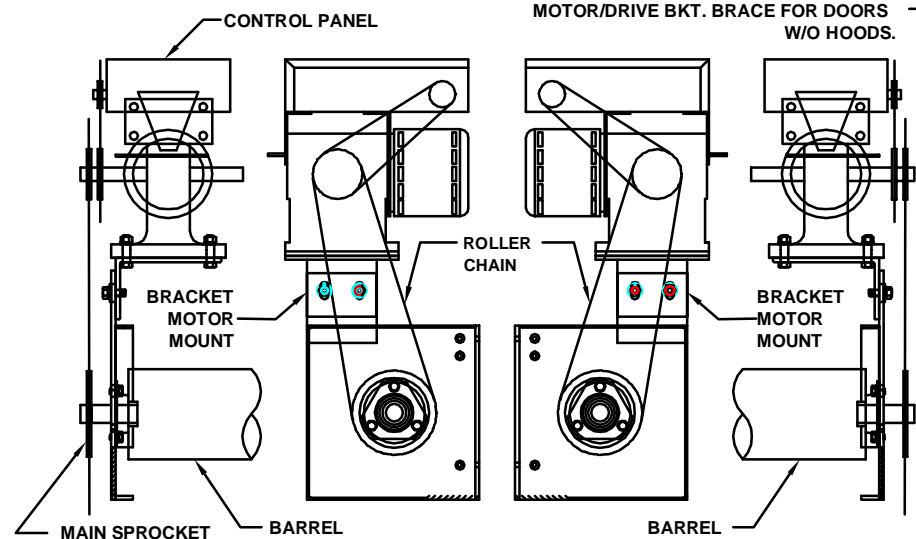
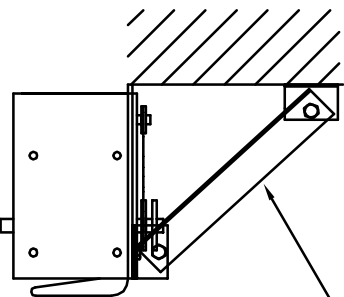

FIG B3

WALL MOUNT MOTOR OPERATOR

CAUTION: DOORS INSTALLED WITHOUT HOODS MUST HAVE MOTOR/BRK. BRACE INSTALLED TO AVOID FLEXING OF BRACKET AND POSSIBLE INJURY.

1) AFTER DOOR IS INSTALLED AND BRACKET PLATES ARE PERPENDICULAR TO WALL, ATTACH MOTOR/BKT BRACE TO BRACKET AND WALL AS SHOWN.

2) MAKE SURE THAT BOLTS ARE TIGHT AND BRACKET PLATE IS PERPENDICULAR TO WALL.

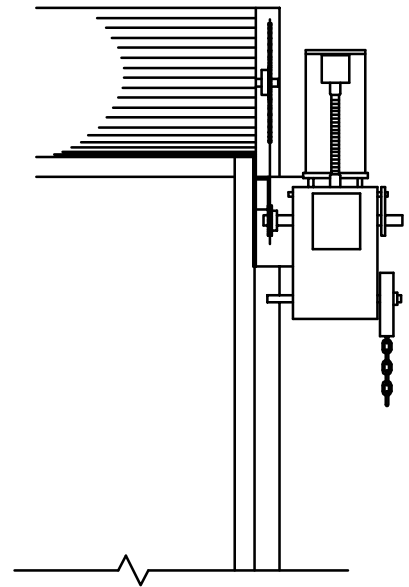
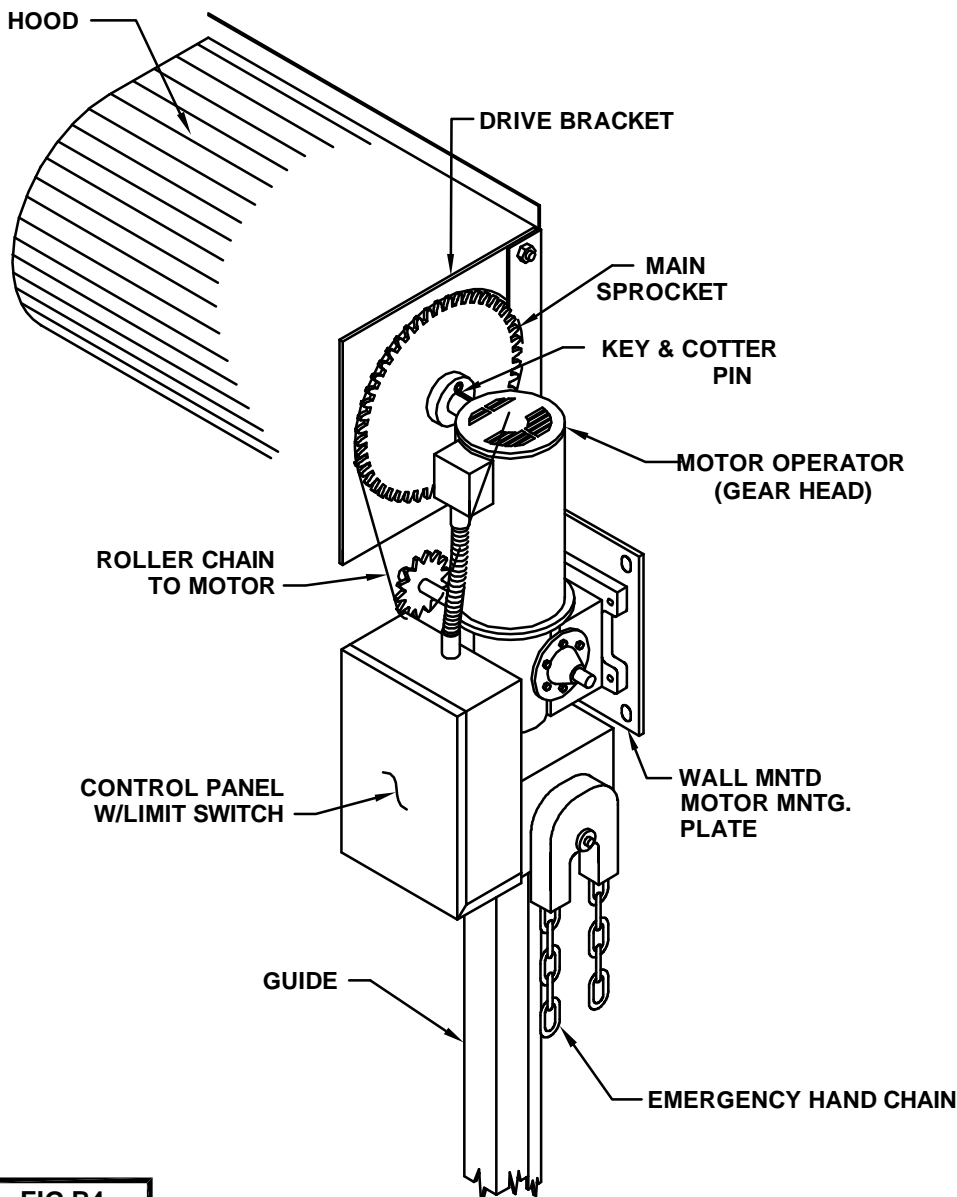
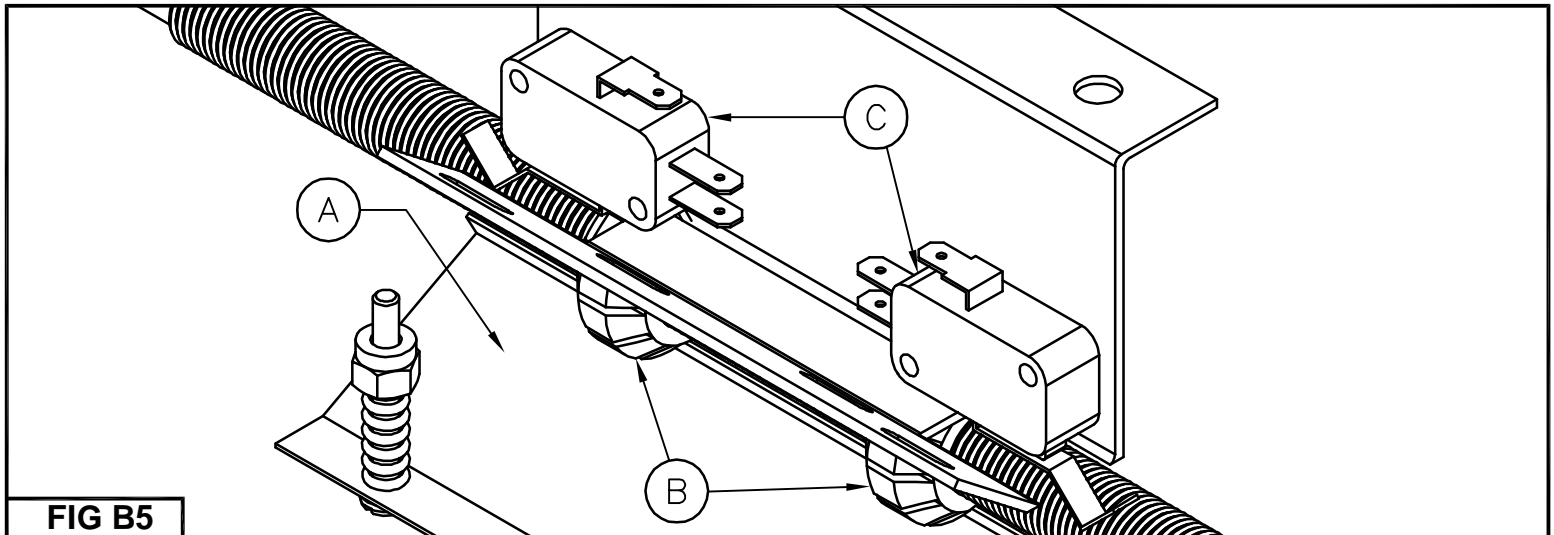

FIG B4

INSTRUCTIONS FOR SETTING ROTARY LIMIT SWITCH

**CAUTION: ONLY ADJUST THE ROTARY LIMIT SWITCH WITH THE POWER "OFF".
ONLY TRAINED PERSONNEL SHOULD SET OR ADJUST THE LIMIT SWITCH.**

- 1) Using the manual operator, lower or raise the curtain to the midpoint of the opening.
- 2) Open the limit switch box and identify all parts. (A) DETENT PLATE (B) CAM NUT (C) BASIC SWITCHES
- 3) Depress the spring loaded detent plate and rotate each cam nut approximately 1/8" from the basic switches as shown below.



- 4) Apply power to the motor and test the operation of the door. As the door is opening the "open" cam nut should be traveling towards the "open" basic switch. As the door is closing the "close" cam nut should be traveling towards the "close" basic switch. The cam nuts are designed to activate the basic switches and terminate the travel of the door.
- 5) **IMPORTANT:** Check that the motor is correctly wired in regards to rotation and direction. Operate the open and close functions. If the mode of operation is incorrect (when the "open" functions of the control station makes the door close or the "close" functions of the control station makes the door open) or the rotation direction of the cam nut is incorrect (cam nut travels toward the "open" basic switch when closing and the "close" basic switch when opening) discontinue operation of the door and check the wiring. All wiring must be correct before proceeding.
- 6) Once the correct rotation and orientation of the control functions and basic switches has been determined, proceed with the finalized setting of the rotary limit switch.
- 7) Turn power off. With the manual operator lower the door to the fully closed position. Rotate the "close" cam nut toward the "close" basic switch until the switch clicks. The "close" basic switch is now set. Raise the door to the fully open position. Rotate the "open" cam nut toward the "open" basic switch until the switch clicks. The open basic switch is now set.
- 8) Make sure that the detent plate is fully engaged in the slots of each cam nut, replace the cover on the limit switch and apply power to the motor operator to test the operation of the door. If further fine tuning adjustments are required make sure that the power is off before adjustments are made.

INSTRUCTIONS FOR TUBULAR MOTOR LIMIT SWITCH ADJUSTMENT

Limit switch adjustment tool and instructions are provided with the tubular motor. Refer to tubular motor installation instructions manual for limit switch adjustment.

NOTE: The motor has a built in thermal cutoff. If after several minutes of use the motor will not run in either direction, allow the motor to cool for approximately 20 minutes.

SAFETY EDGE COIL CORD/ CORD REEL INSTALLATION INSIDE DOOR WITH MOTOR MOUNTED CONTROLLER

COIL CORD INSTALLATION INSTRUCTIONS:

1. LOCATE CONTROL PANEL KNOCK OUT CLOSEST TO DOOR OPENING & IN LINE WITH MALE CONNECTOR,
2. LOCATE COIL CORD/CORD REEL AS NOT TO INTERFERE WITH ROLLER CHAIN.
3. INSTALL ELBOW (AS SHOWN).
4. WIRE TO TERMINALS AS INDICATED ON WIRING DIAGRAM.
5. CONNECT TWIST LOCK PLUG (WIRE FEMALE TO COIL CORD/CORD REEL IF SHIPPED LOOSE).
6. TEST REVERSING BOTTOM BAR FOR CORRECT OPERATION.

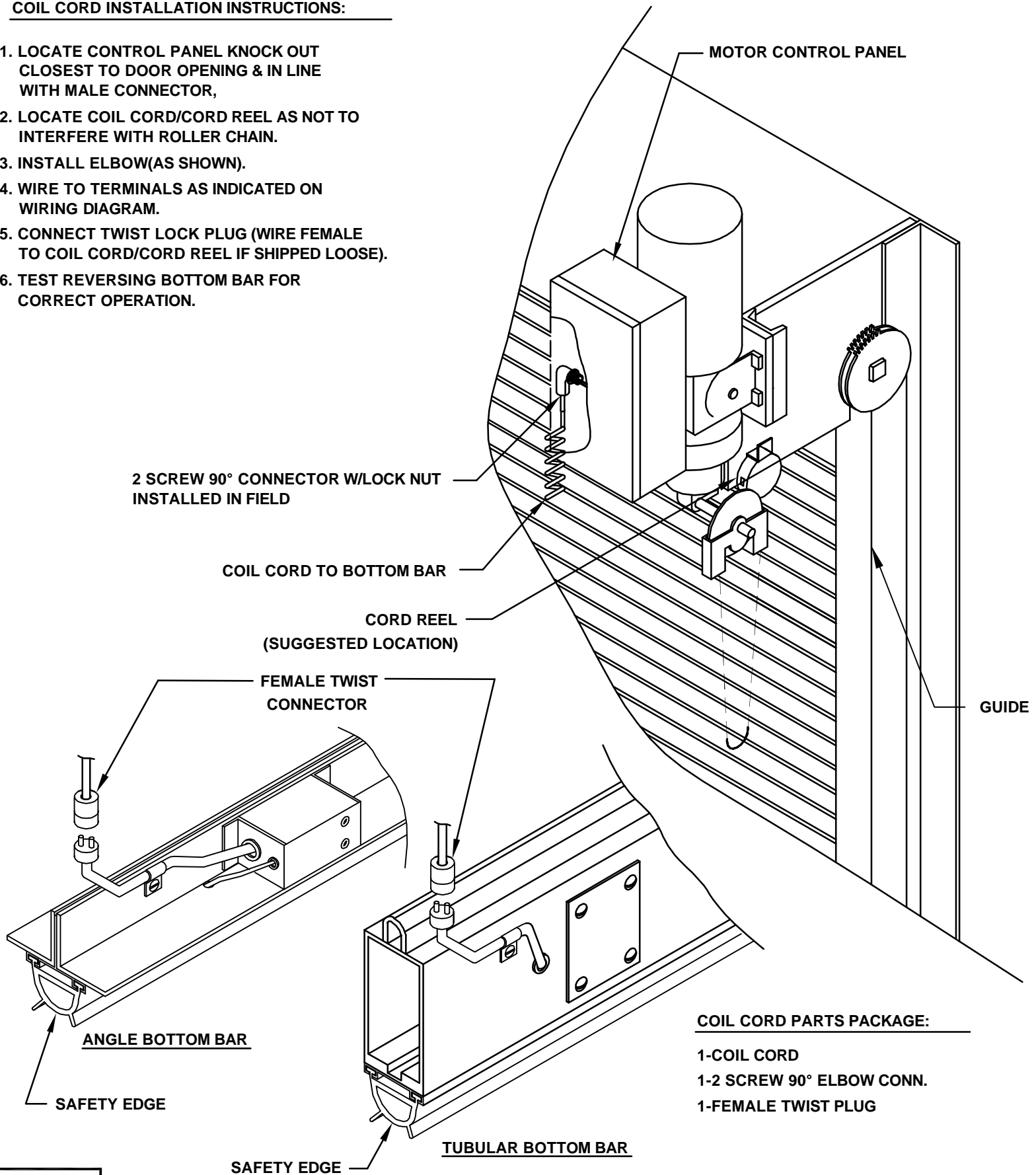

COIL CORD PARTS PACKAGE:

- 1-COIL CORD
- 1-2 SCREW 90° ELBOW CONN.
- 1-FEMALE TWIST PLUG

FIG C1

SAFETY EDGE COIL CORD/ CORD REEL INSTALLATION OUTSIDE AND ABOVE MOUNTED DOORS

MOTOR SHOWN RECTANGULAR & DOTTED FOR CLARITY
THE CONDUIT FROM THE CONDUIT BOX TO THE
CONTROLLER IS TO BE DONE IN FIELD

COIL CORD OPTION:
2 X 4 CONDUIT BOX
SUPPLIED BY COOKSON

CORD REEL OPTION:
CONDUIT BOX W/2 PRG
OUTLET TO BE SUPPLIED
BY OTHERS.

COIL CORD/CORD REEL INSTALLATION:

1. FASTEN CONDUIT BOX W/MTG PLATE TO WALL AS SHOWN USING Ø1/4 FASTENERS.
2. INSTALL 2 SCREW 90° ELBOW AS SHOWN IF USING COIL CORD.
3. WIRE COIL CORD/CORD REEL AS INDICATED ON WIRING DIAGRAM.
4. CONNECT TWIST LOCK PLUG (WIRE FEMALE TO COIL CORD/CORD REEL IF SHIPPED LOOSE).
5. TEST REVERSING BOTTOM BAR FOR CORRECT OPERATION.

USE (2) #12 PAN HD
SCREW W/SHIELDS FOR
MASONRY MTG.

CORD REEL

CORD REEL (SUGGESTED LOCATION)
SEE ABOVE DETAIL

COIL CORD PARTS PACKAGE:

- 1 - COIL CORD
- 2 - 2 SCREW 90° ELBOW
- 3 - FEMALE TWIST LOCK PLUG

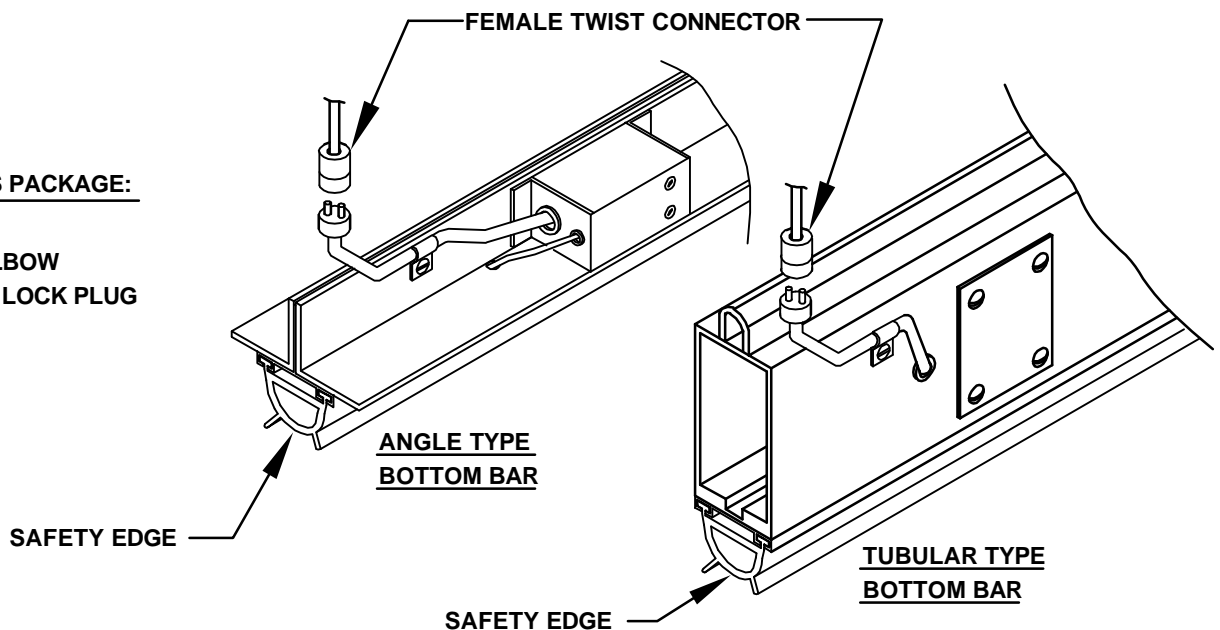

FIG C2