



**SERVICE FIRE DOORS
INSTALLATION INSTRUCTIONS**

SERVICE FIRE DOOR INSTALLATION INSTRUCTIONS

TABLE OF CONTENTS

PAGE#	DESCRIPTION	FIG#
2	Safety Check List / Pre Installation Instructions	
<u>GUIDE INSTALLATION</u>		
3	Guide Installation	1 / 2 / 3
4	Guide Installation (Cont)	4 / 5 / 6
5	Optional Welded Wall Angle Installation for Warnock Hersey	7
6	Fastener Table	
6	Guide Groove Dimension Table	
<u>BARREL & BRACKET ASSEMBLY</u>		
7	Barrel & Bracket Assembly - General	8 / 9
8	Barrel & Bracket Assembly - Pushup Type III Single/Dual Spring	10 / 11
9	B&B Assy - Manual Oper Single & Dual Spring	12 / 13
10	B&B Assy - Motor Oper - Vert/Horiz/Side Mount	14 / 15
11	B&B Assy - Compound Motor & Chain Operated	16 / 17 / 18 / 19
12	B&B Assy - FDO-A & FDO-B Motor Oper	20 / 21
13	B&B Assy - FD-2 Vert Mount Chain/Crank Operated	22 / 23
14	B&B Assy - FD-2A Vert Mount Chain Operated	24 / 25
<u>CURTAINS / HOODS</u>		
15	Curtain Assy for SD/FD/Grille Doors	26 / 27
16	Hood Support Mounting Instructions	28 / 29
17	Hood Installation	30 / 31
<u>TENSIONING INSTRUCTIONS</u>		
18	FD Tensioning Instructions - Single Spring Gov / Pushup Manual Oper	
19	FD Tensioning Instructions - Dual Spring Gov / Pushup Manual Oper	
20	FD Tensioning Instructions - Single Spring Gov / Manual Oper	
21	FD Tensioning Instructions - Dual Spring Gov / Manual Oper	
22	FD Tensioning Instructions - Motor Operated	
23	FD Tensioning Instructions - Compound Motor Oper /Chain Oper	
24	FD Tensioning Instructions - FDO Motor Operated	
24	FD Tensioning Instructions - FD-2A Chain Operated	
25	FD Resetting Instructions - Manual Pushup Operation	32
26	FD Resetting Instructions - Manual/Motor Operation	33 /34
<u>TROUBLE SHOOTING</u>		
27	FD Trouble Shooting - Type III - Vibrattech Gov	
28	FD Trouble Shooting - Type III - Vibrattech Gov (Cont)	35
29	Load Holding Brake Adjustment - Compound Chain Oper	36
30	Fusible Link System	37
31	Instructions for Setting Rotary Limit Switch	38
<u>SAFETY EDGES / DEVICES</u>		
32	Safety Edge Coil Cord / Cord Reel Install - Inside Door	39
33	Safety Edge Coil Cord / Cord Reel Install - Outside & Above	40
34	Failsafe Safety Edge Installation Instructions	41
35	Setting Instructions for Featheredge Switch	42 / 43
36	Top & Bottom Safety Limit Switch Installation	44
<u>WEATHER STRIPPING / MISC</u>		
37	Brush Type Gasketing Install Instruction	45 / 46 / 47
38	Electr Connections for FD-2A to Alarm Syst/Smoke Detectors	48

FREIGHT DAMAGE INSTRUCTIONS

*****IMPORTANT*****

Immediately upon delivery check condition of materials for visible concealed freight damage incurred in transit.

Under no condition should installation be made without authorization, as neither the carrier nor the Manufacturer will assume responsibility for labor costs involved in replacing damaged material that has been installed.

FOLLOW THE DIRECTIONS BELOW:

CONCEALED DAMAGE:

- (a) Must be inspected by carrier's representative within 15 days from date of delivery.
- (b) Consignee must obtain copy of Inspection Report.
- (c) Material should not be moved from point of delivery to other premises prior to discovery and/or reporting of damage.
- (d) Container and packing should be retained by consignee until inspection is made.

VISIBLE DAMAGE:

- (a) Must be inspected by carrier's representative within 15 days from date of delivery.
- (b) Consignee must obtain copy of Inspection Report.
- (c) Material should not be moved from point of delivery to other premises prior to discovery and/or reporting of damage.
- (d) Container and packing should be retained by consignee until inspection is made.

NOTE: IF DAMAGE IS CERTAIN, GOODS SHOULD NOT BE UNPACKED UNTIL INSPECTION IS MADE. IF DAMAGE IS UNCERTAIN, PACKAGES MAY BE OPENED BUT PACKING MATERIAL MUST BE SAVED UNTIL INSPECTION IS MADE.

INCOMPLETE DELIVERY:

- (a) Should be noted on delivery receipt.
- (b) Acknowledged by driver's signature.
- (c) Start tracing immediately.
- (d) Notify shipper.

RETURNING DAMAGED MATERIAL:

If damaged to the extent that it is necessary to return to the Manufacturer to be repaired, please do as follows:

- (a) Obtain permission to do so from the delivering carrier.
- (b) Route the return shipment via the identical carrier(s) involved in the original shipment.
- (c) Notify the Manufacturer when shipped.

PRE-INSTALLATION INSTRUCTIONS



READ AND FOLLOW THESE INSTRUCTIONS THOROUGHLY - THE COOKSON COMPANY WILL NOT BE HELD RESPONSIBLE FOR ANY CHARGES INCURRED THROUGH MISSING PARTS, OPERATION, OR DAMAGE- UNLESS THESE INSTRUCTIONS HAVE BEEN FOLLOWED.

- 1) If you have received more than one door, you will find that all major parts and pieces for any one door are marked with corresponding numbers; therefore, a complete door should be composed of parts bearing the same numbers and letters.

DO NOT INTERCHANGE PARTS FROM ONE DOOR TO ANOTHER!!!

- 2) Before installing the door see that all component markings agree.
- 3) Before attempting installation of the door and, specifically, before leaving the jobsite make certain you have read and adhered to the attached "Safety Check List".
- 4) Should there be any discrepancies in the job conditions or manufactured materials, contact The Cookson Company in writing or by calling 1-800-294-4358 for Western U.S. and Canada or 1-800-390-8590 for Eastern U.S. and Canada. If door was purchased by a Cookson Distributor and sold to another party they should contact the Distributor for Warranty or Repair parts.

SAFETY CHECK LIST

IN ORDER FOR YOU TO ASSURE YOUR CUSTOMER THAT THIS DOOR HAS BEEN INSTALLED PROPERLY AND IN A SAFE MANNER, WE ASK THAT YOU CHECK THE FOLLOWING BEFORE LEAVING THE JOBSITE.

- 1) Make certain that the proper amount of tension has been applied to the torsion springs, in order to properly counterbalance the weight of the curtain.
- 2) Assure yourself that the tension wheel is securely fastened in place.
- 3) Assure yourself that sprockets or gears requiring keys have the correct keys installed and drive shaft sprockets or gears are retained by cotter pins.
- 4) Recheck the setscrews (One over key - the other located at 45° from key) in each sprocket or gear for tightness.
- 5) Check all fasteners holding guides to building structures.
- 6) Check all fasteners used in assembling door components.
- 7) Instruct owner or his/her representative in the proper method of operating this door.

FIRE DOORS GUIDE INSTALLATION

Depending on your specific job conditions, you have received guides that appear as shown below.

TYPE I ASSY

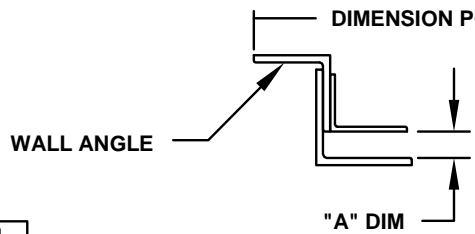

TYPE II ASSY

**STANDARD
FACE OF WALL
MOUNTED GUIDE**

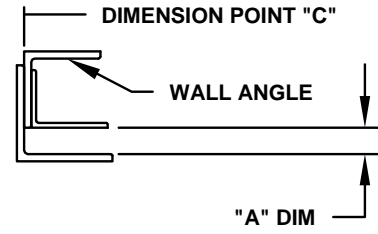

FIG 1

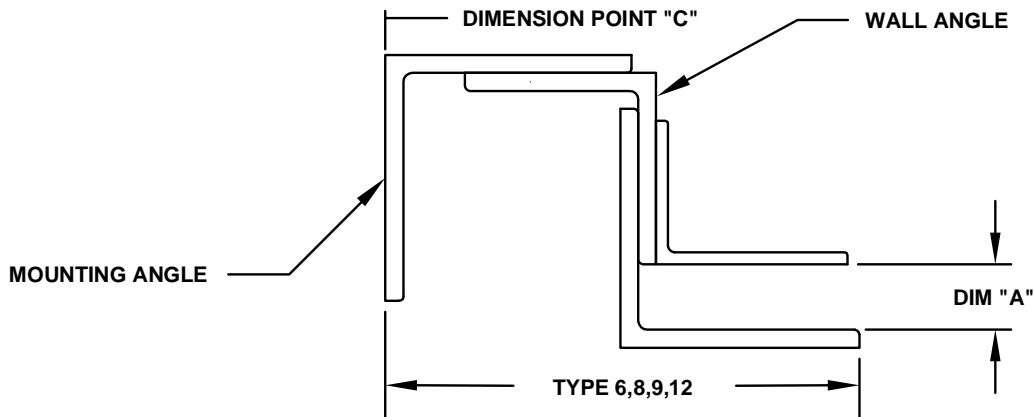

FIG 2

TYPE 3

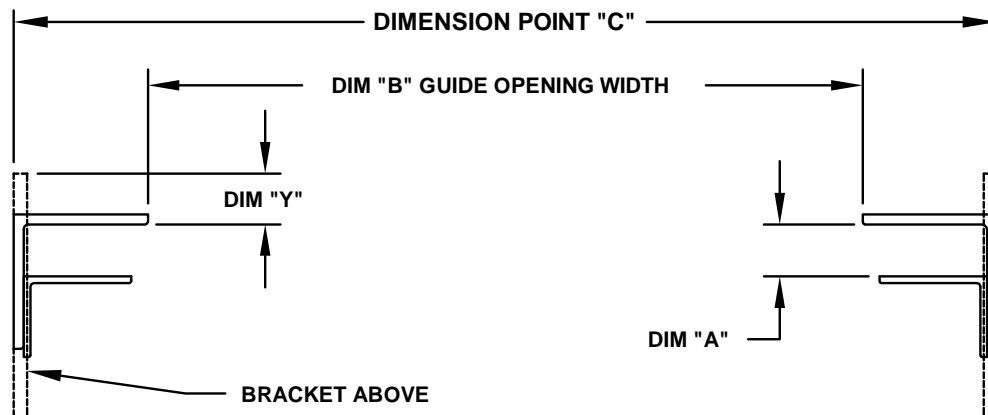

FIG 3

FIRE DOORS GUIDE INSTALLATION

TYPE 4

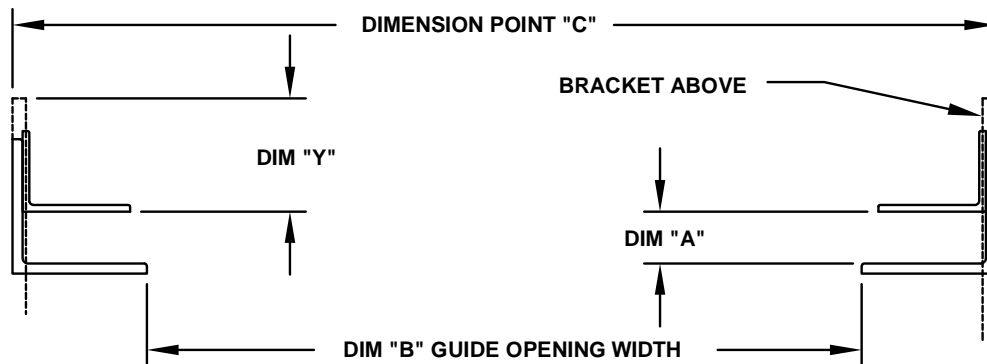

FIG 4

- 1) Locate guide dimension point for both left and right jamb. Measurement between dimension points must equal dimension "C".
- 2) For typical installation for Type I and II (See FIG 1) guide assemblies, Dimension point "C" is centered around jamb opening - (if side room permits) - if there are questions check job construction drawings (if available).
- 3) Check the Guide opening measurement. Locate a mark on the floor at the tip of each guide and measure. Guide measurement must equal Dim "B". (See FIG 6) THIS IS CRITICAL If guide opening does not equal Dim "B", STOP and redo steps 1 and 2.
- 4) Scribe a plumb line on the wall at dimension points.
- 5) Place the guides against the scribed line and with the tops of guides level, mark the location of the mounting holes. **NOTE:** Guide types 2, 6, 8, 9 & 12 may have to be disassembled.
NOTE: MOUNTING HOLES TO BE LOCATED AT THE TOP OF EACH SLOT.
- 6) Drill mounting holes for wall fasteners and mount the guides. (See PAGE 6 for fastener type) Reassemble guides if necessary.
- 7) Make sure that the width of the guide groove is equal to Dim "A". (See Page 6) Adjust if necessary.

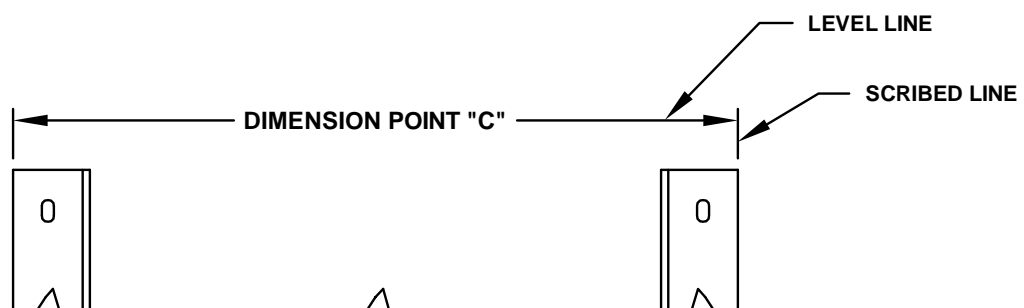

FIG 5

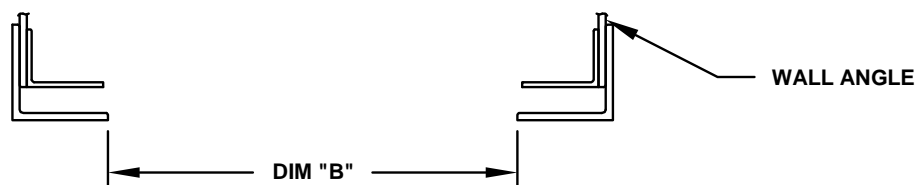

FIG 6

OPTIONAL WELDED WALL ANGLE INSTALLATION APPVD FOR WARNOCK HERSEY AND UL LABELED DOORS

NOTE: APPROVED FOR STRUCTURAL STEEL JAMBS ONLY.

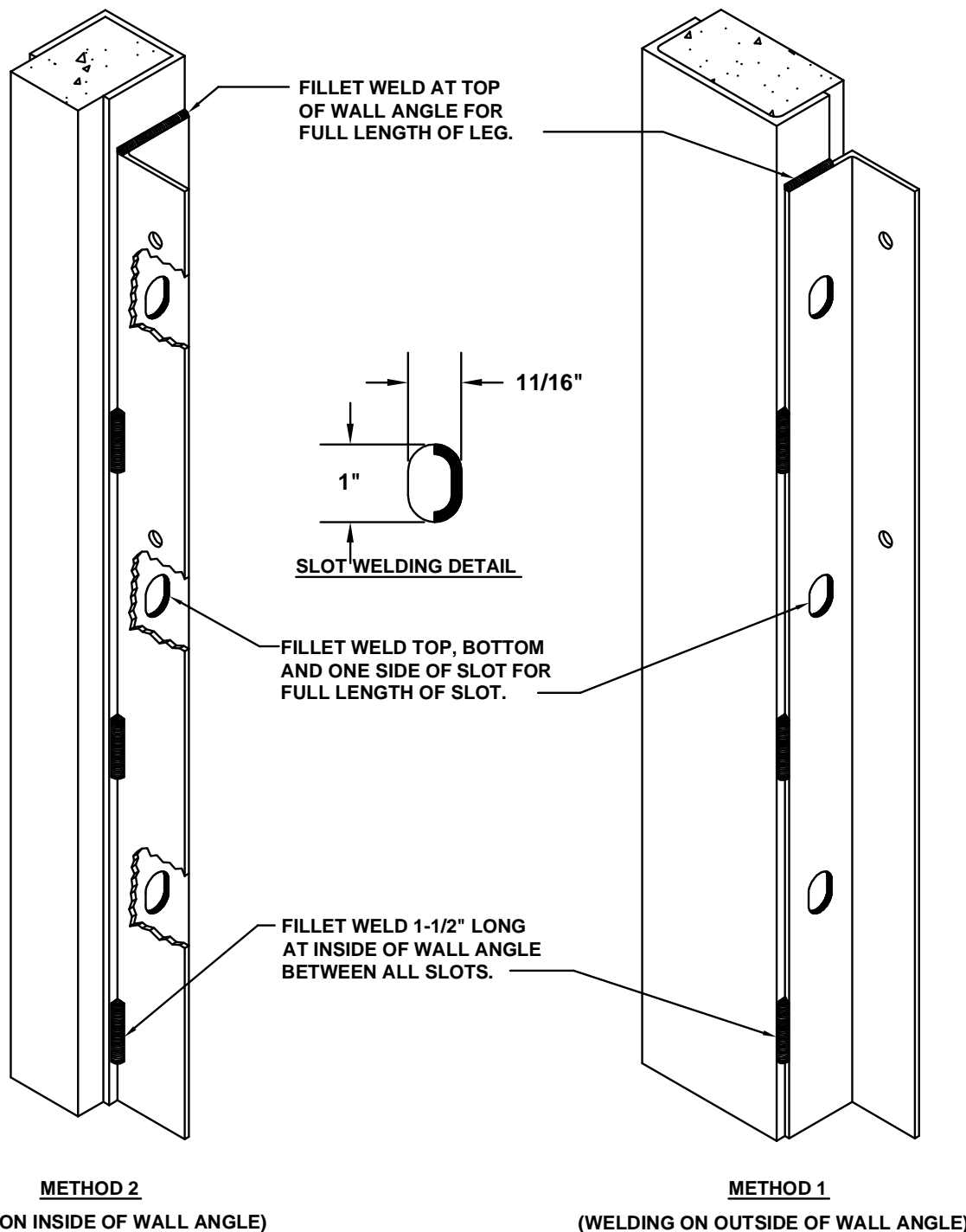

FIG 7

Fillet weld sizes are to be equal to the wall angle thickness.

(Fillet welds to be minimum 3/16" wide).

Use E6011/E6011 electrodes or electrodes of equivalent strength.

All welds to be done "vertical-up" (start from the base of an individual weld and weld upwards).

Welding provisions to be in compliance with U.B.C. Std. #27-6.

FASTENER TABLE

TYPE OF CONSTRUCTION TO WHICH FASTENER EMBEDS	TYPE OF FASTENER TO USE	HOLE SIZE (DRILL DIA.)	TAP SIZE (IF REQ'D)	DEPTH OF HOLE
CONCRETE/ MASONRY	Ø1/2" THRU BOLTS	Ø5/8" CARBIDE	—————	THRU WALL
	Ø5/8" THRU BOLTS	Ø3/4" CARBIDE	—————	THRU WALL
	Ø3/4" THRU BOLTS	Ø7/8" CARBIDE	—————	THRU WALL
CONCRETE WIDE WALL	Ø1/2" X 5-1/2" WEDGE ANCH.	Ø1/2" CARBIDE	—————	4" MIN
	Ø5/8" X 6" WEDGE ANCH.	Ø5/8" CARBIDE	—————	5" MIN
	Ø3/4" X 8-1/2" WEDGE ANCH.	Ø3/4" CARBIDE	—————	6" MIN
MASONRY OR BRICK WIDE WALL	Ø5/8" X 4-1/4" SLEEVE ANCH. (Ø1/2" BOLT)	Ø5/8"	—————	4" MIN
	Ø3/4" X 6-1/4" SLEEVE ANCH. (Ø5/8" BOLT)	Ø5/8"	—————	5" MIN
STEEL	Ø1/2" BOLT	Ø27/64"	1/2"-13UNC	—————
	Ø5/8" BOLT	Ø17/32"	5/8"-11UNC	—————
	Ø3/4" BOLT	Ø21/32"	3/4"-10UNC	—————

NOTE: See the previous page if the guides are to be welded to the jambs.

GUIDE GROOVE DIMENSION TABLE

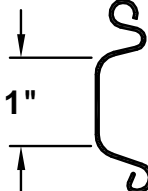
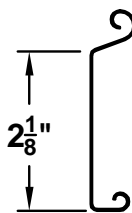
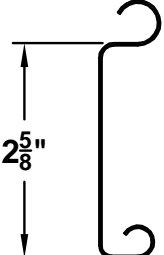
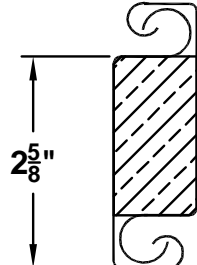
SLAT NO.	1	5	4	45 DBL.INSUL
SLAT PROFILE				
DIM "A"	1"	1"	1 1/8"	1 1/4"

BARREL AND BRACKET ASSEMBLY

YOU MUST DETERMINE THE FOLLOWING:

- 1) Hand of Door (LH or RH).
- 2) Type of Operation (Manual, Motor, Compound Motor / Chain)
- 3) Type of Governor (Pallet or Type III Viscous Governor).
- 4) Single or Dual Spring (Dual Spring only applies to Manually Operated).

IDENTIFY APPROPRIATE BARREL & BRACKET ASSEMBLY FIGURE (FIGURES 11 THRU 25)
ALL BARREL & BRACKET ASSY FIGURES SHOWN IN RH VIEW (LH VIEW OPPOSITE)

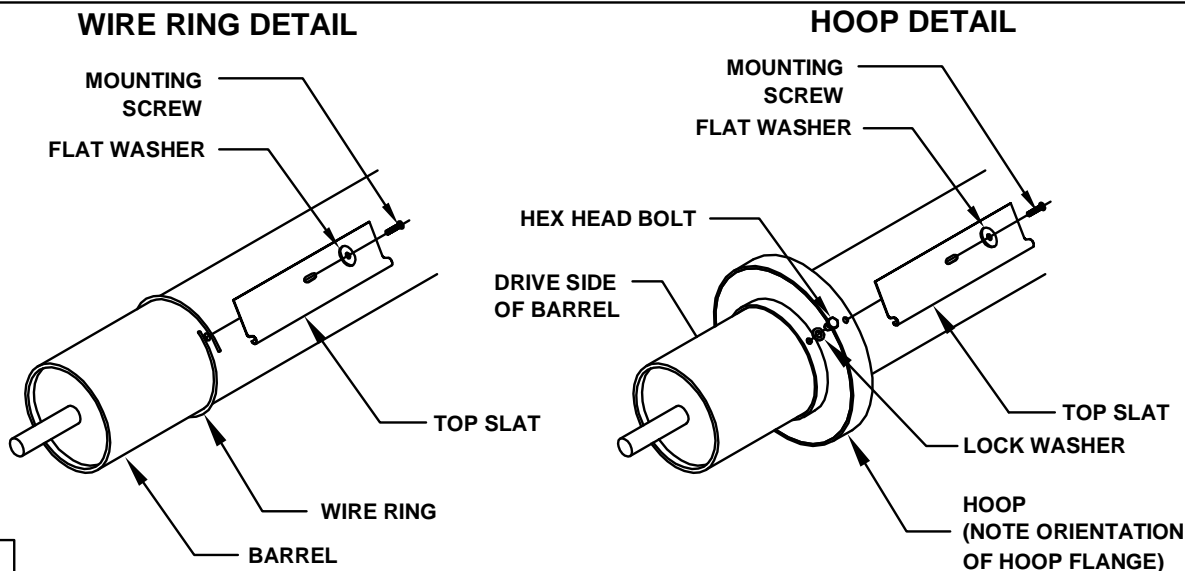

FIG 8

- 2) Slide the mounting brackets onto their respective ends of the barrel and raise the entire assembly into position at the head of the opening.
- 3) Using the carriage bolts as shown in FIG 9, bolt the brackets to the wall angle.

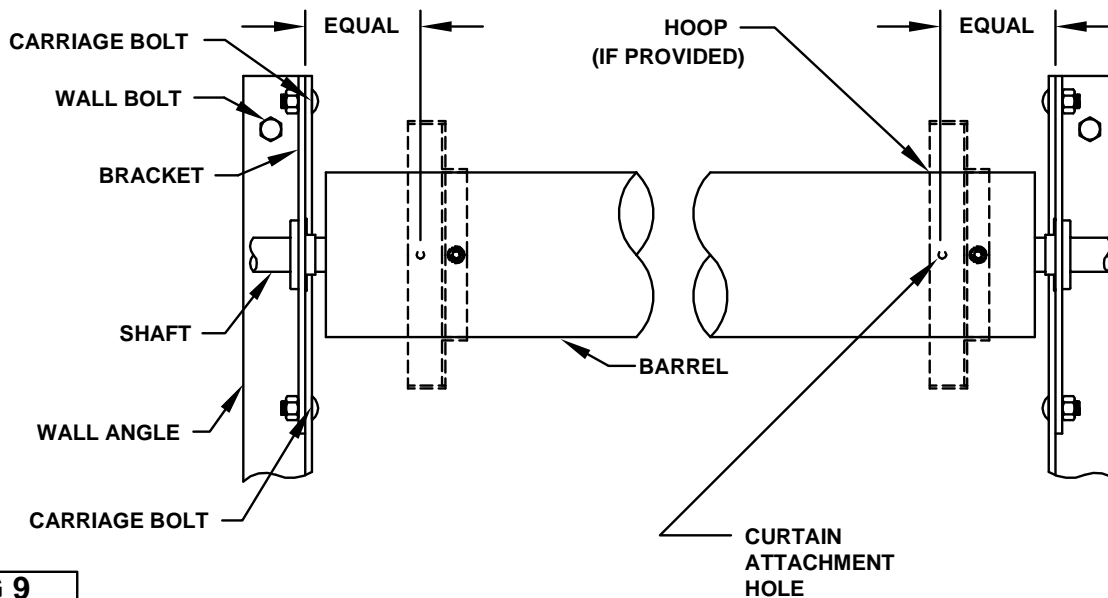

FIG 9

- 4) Position the barrel, with an equal distance from the first curtain attachment hole, to the inside face of both brackets. See FIG 9. Assemble bracket components according to appropriate barrel & bracket assembly figure.

BARREL AND BRACKET ASSEMBLY PUSH UP TYPE III SINGLE & DUAL SPRING

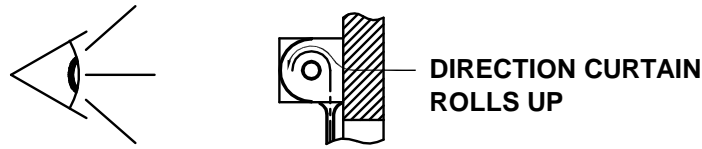
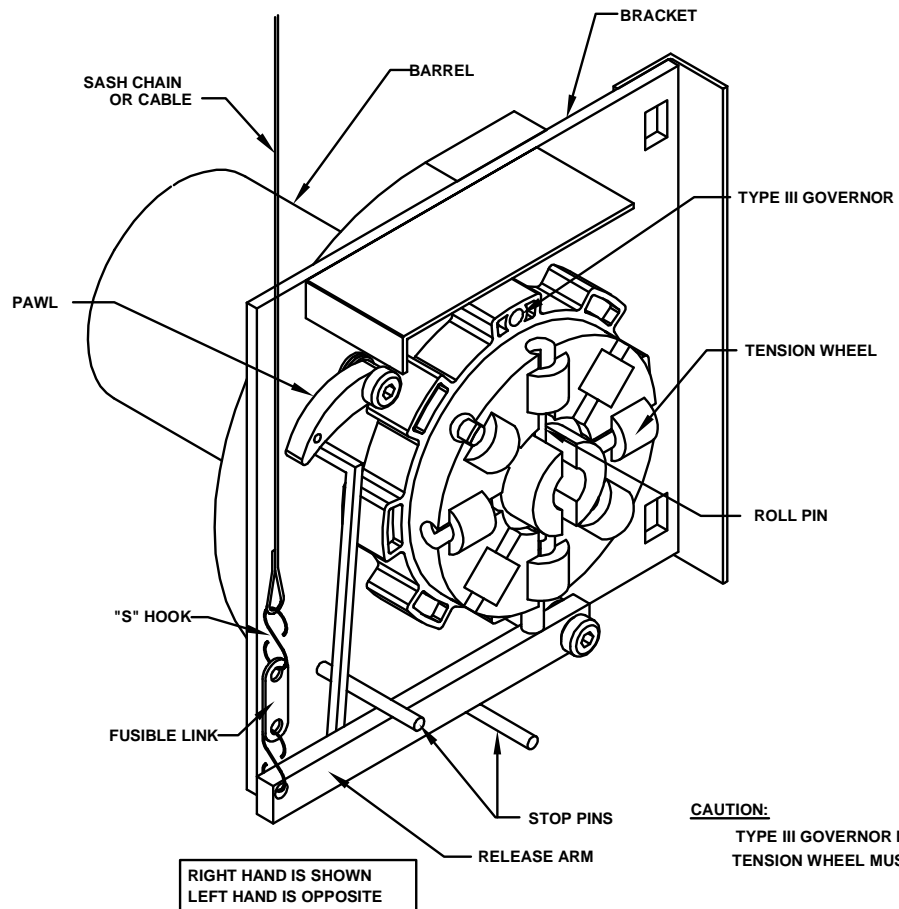

FIG. 10



CAUTION:
TYPE III GOVERNOR MUST BE KEYPED TO SHAFT.
TENSION WHEEL MUST BE SECURED WITH ROLL PIN.

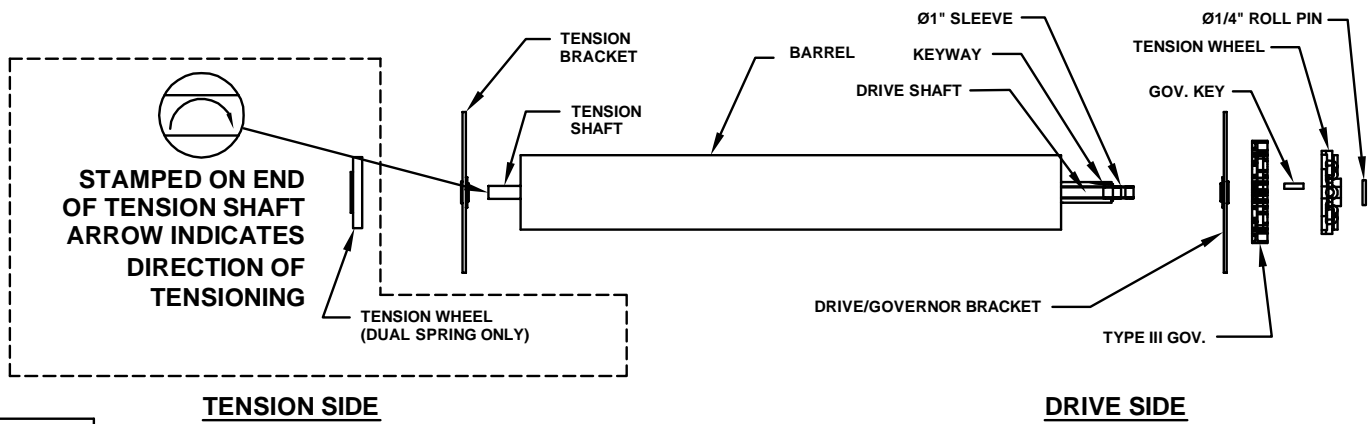

FIG. 11

BARREL AND BRACKET ASSEMBLY MANUAL OPER SINGLE & DUAL SPRING

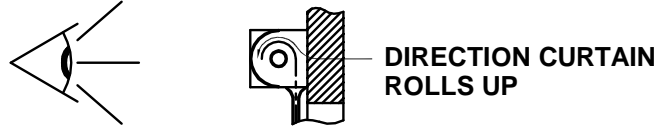
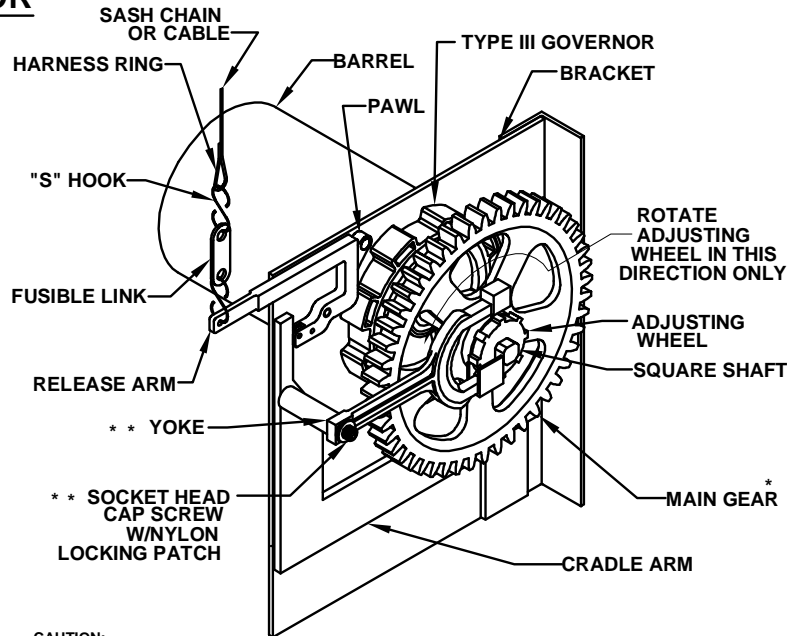

FIG. 12

TYPE III GOVERNOR

RIGHT HAND IS SHOWN
LEFT HAND IS OPPOSITE



CAUTION:
MAIN GEAR AND GOVERNOR MUST BE KEYED TO SHAFT. MAIN GEAR MUST BE POSITIONED AND SECURED BY SET SCREWS SO AS NOT TO CONTACT YOKE.

* MAIN GEAR REQUIRED ON CHAIN, CRANK AND MOTOR OPERATION. IF DOOR IS PUSH UP OPERATION, MAIN GEAR IS NOT REQUIRED AND IS REPLACED WITH A 1-1/4" SET COLLAR.

**DO NOT TIGHTEN THE CAP SCREW AGAINST THE YOKE. THE YOKE MUST BE ABLE TO ROTATE. TIGHTENING THE CAP SCREW MAY IMPAIR THE RELEASE OF THE CRADLE ARM.

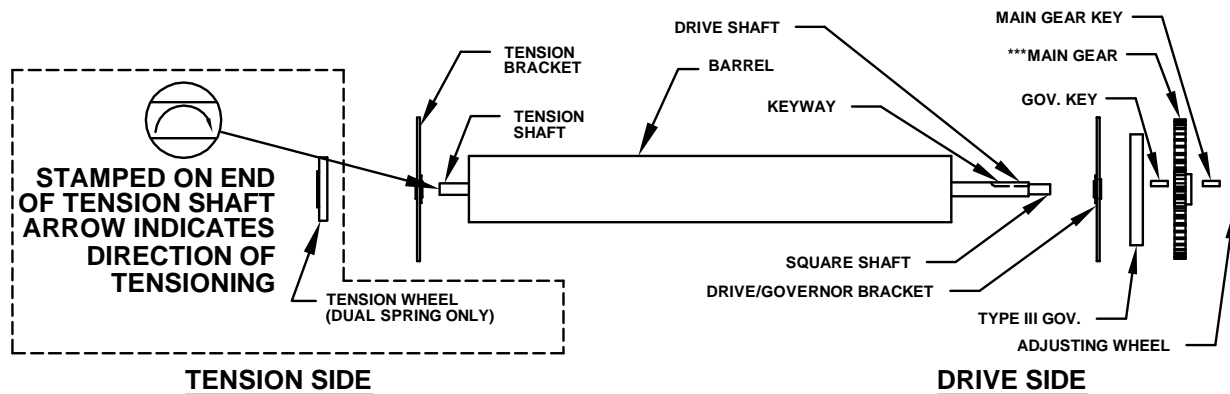

FIG. 13

***Main gear required on chain, crank and motor operation. If door is push up operation, main gear is not required and is replaced with a 1-1/4" set collar.

BARREL AND BRACKET ASSEMBLY MOTOR OPERATED VERT/HORIZ/SIDE MOUNT

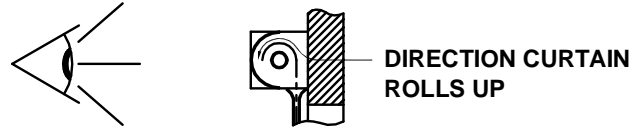

FIG. 14

TYPE III GOVERNOR

RIGHT HAND SHOWN
LEFT HAND OPPOSITE

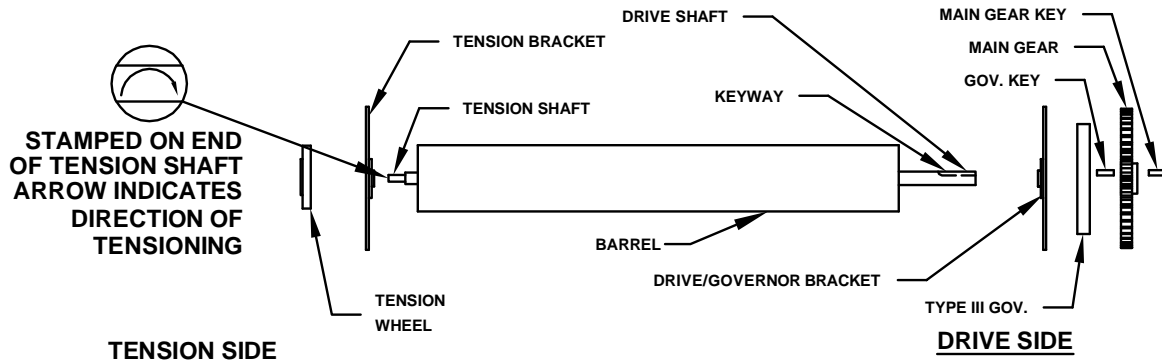
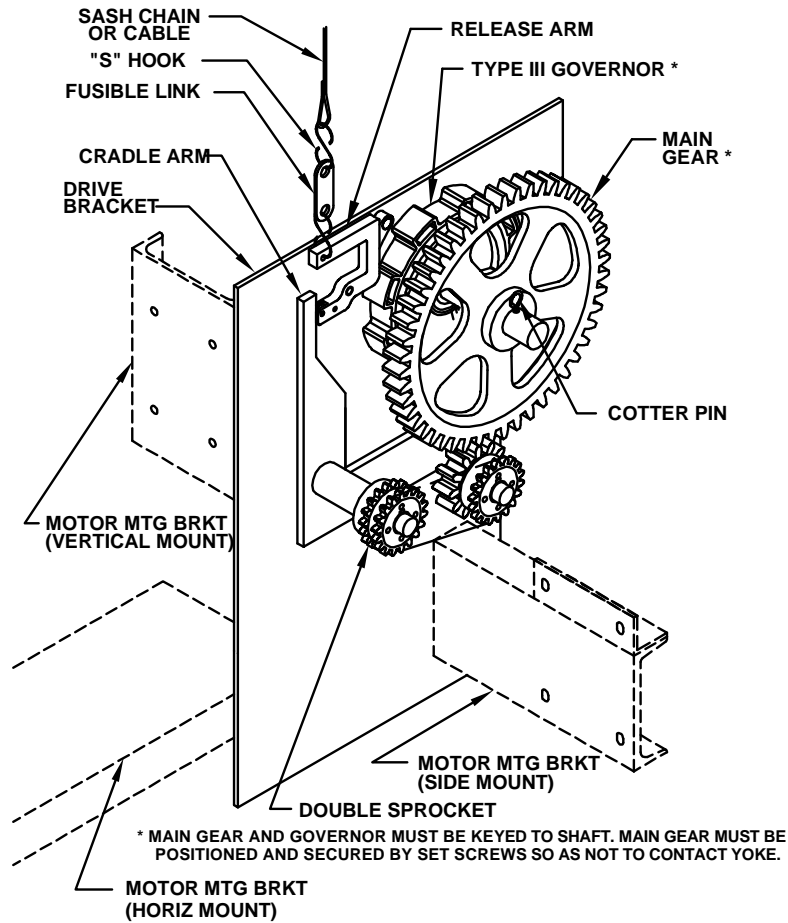

FIG. 15

BARREL AND BRACKET ASSEMBLY COMPOUND MOTOR & CHAIN OPERATED

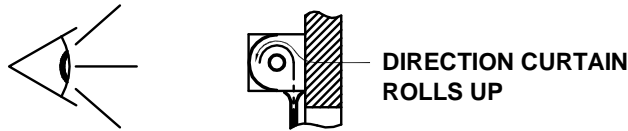

FIG. 16

TYPE III GOVERNOR

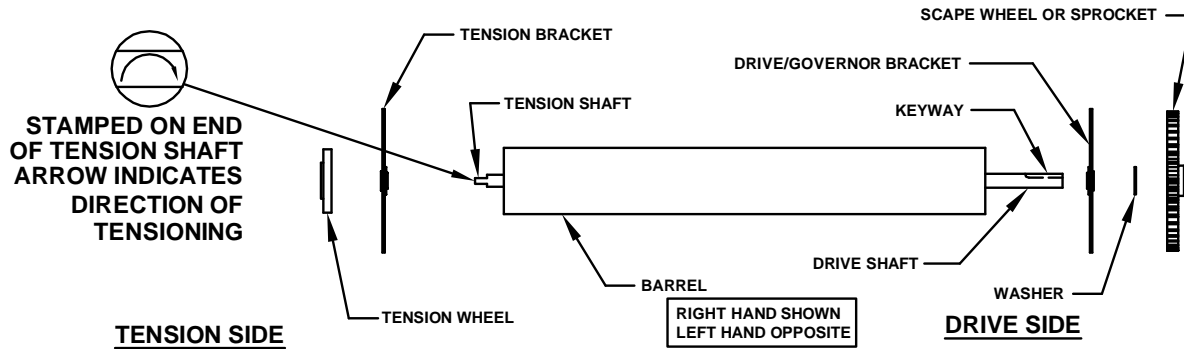
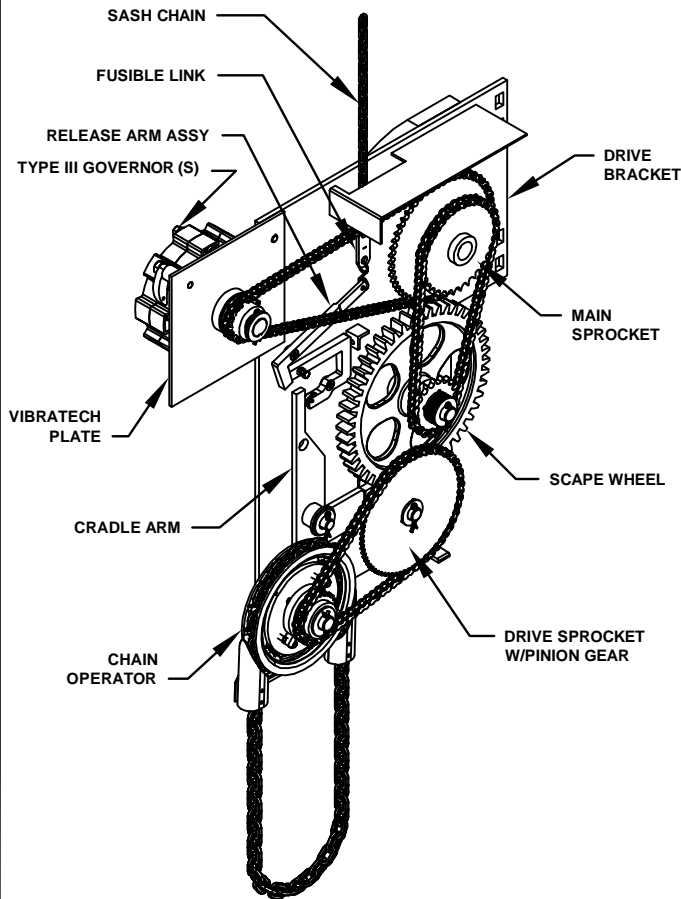

FIG. 17

CHAIN OPERATED COMPOUND OPERATOR



RIGHT HAND SHOWN
LEFT HAND OPPOSITE

FIG. 18

MOTOR OPERATED TYPE III GOVERNOR - COMPOUND VERTICAL MOUNT

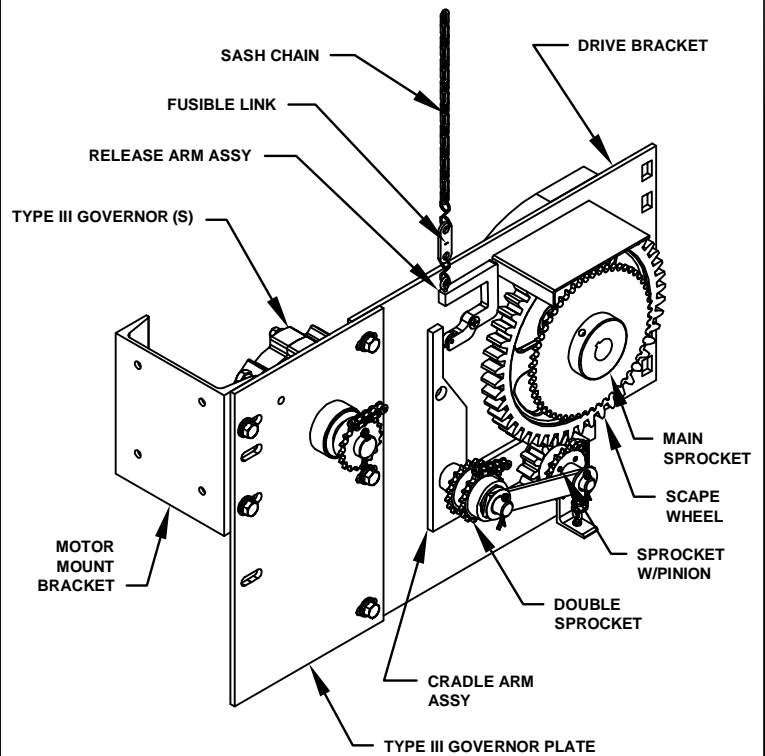

RIGHT HAND SHOWN
LEFT HAND OPPOSITE

FIG. 19

BARREL AND BRACKET ASSEMBLY FDO-A & FDO-B MOTOR OPERATED

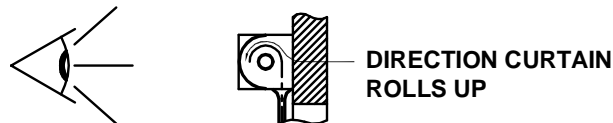
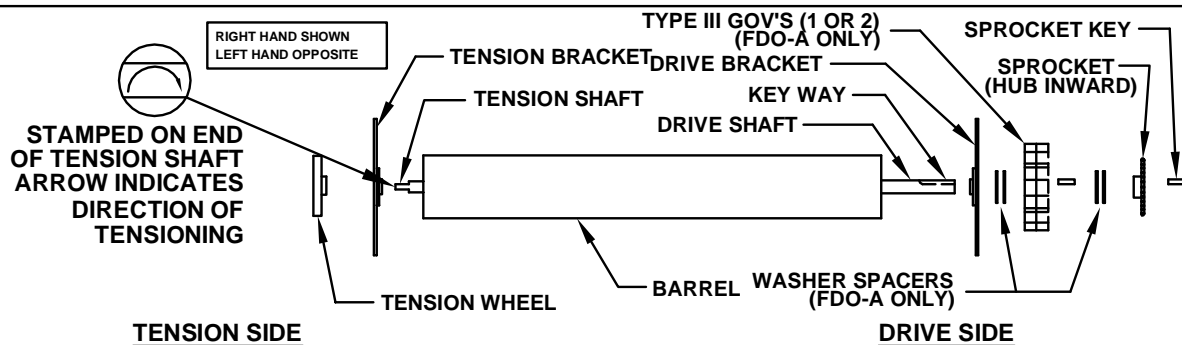
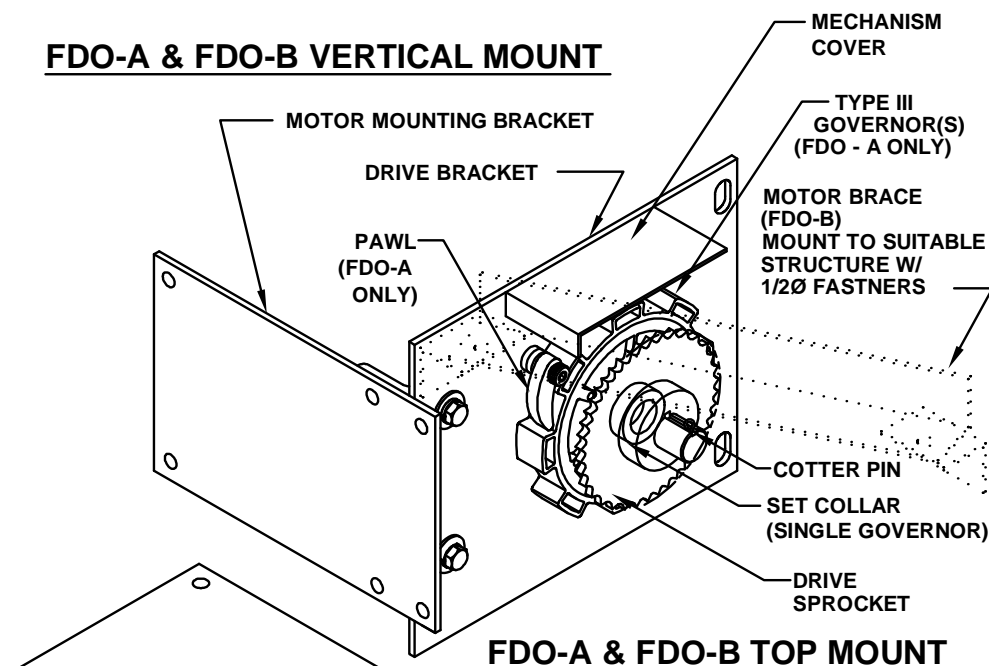

FIG. 20



FDO-A & FDO-B VERTICAL MOUNT



FDO-A & FDO-B TOP MOUNT

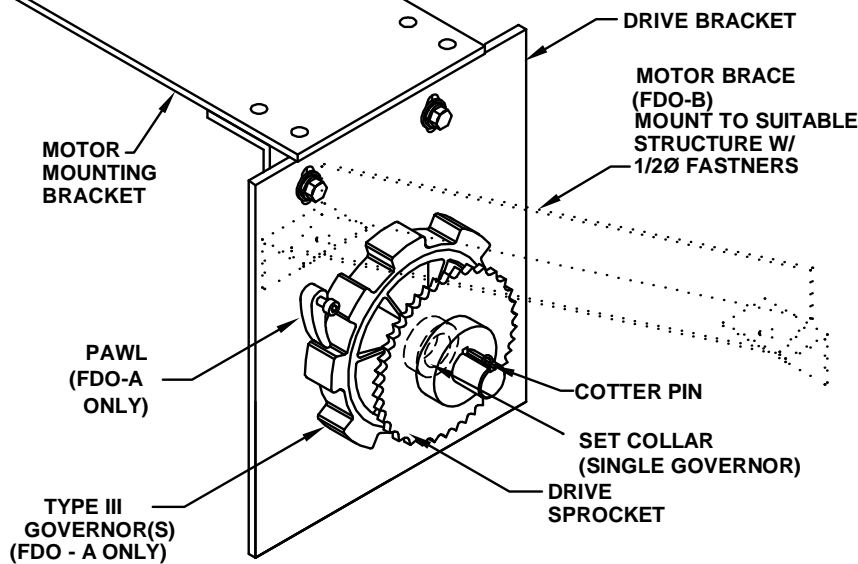

CAUTION:

*DRIVE SPROCKET AND GOVERNOR(S) MUST BE KEYED TO SHAFT.

FIG. 21

BARREL AND BRACKET ASSEMBLY FD-2 VERT MOUNT CHAIN AND CRANK OPERATED



FIG. 22

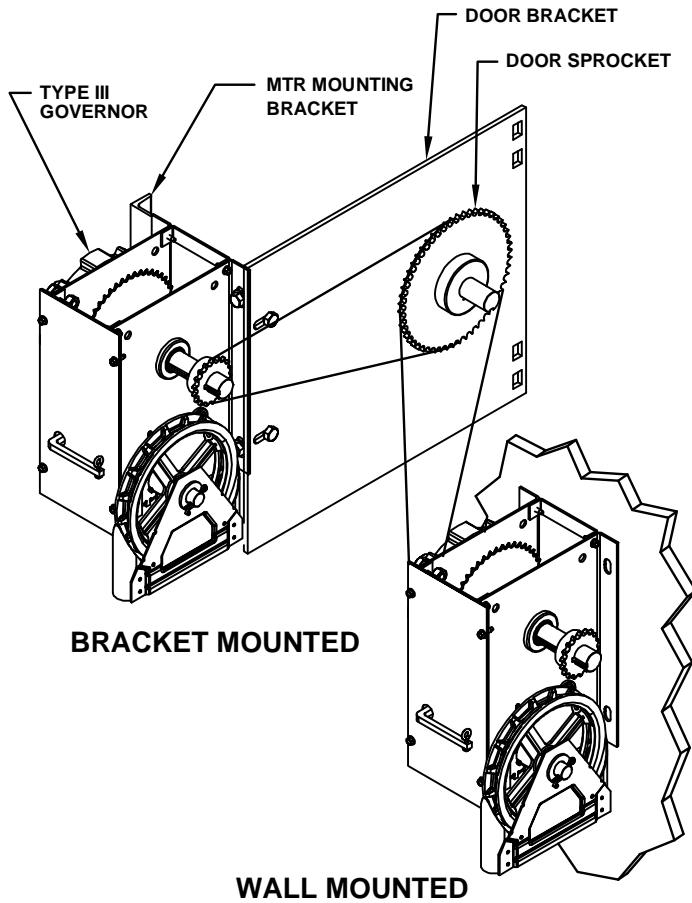
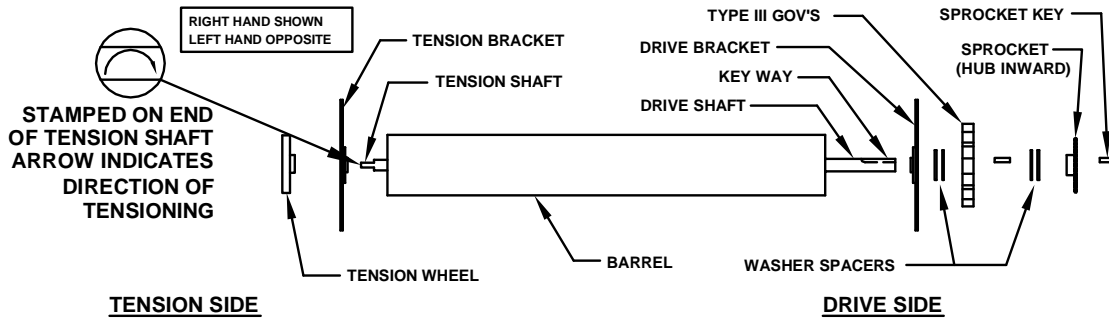

CHAIN OPERATED

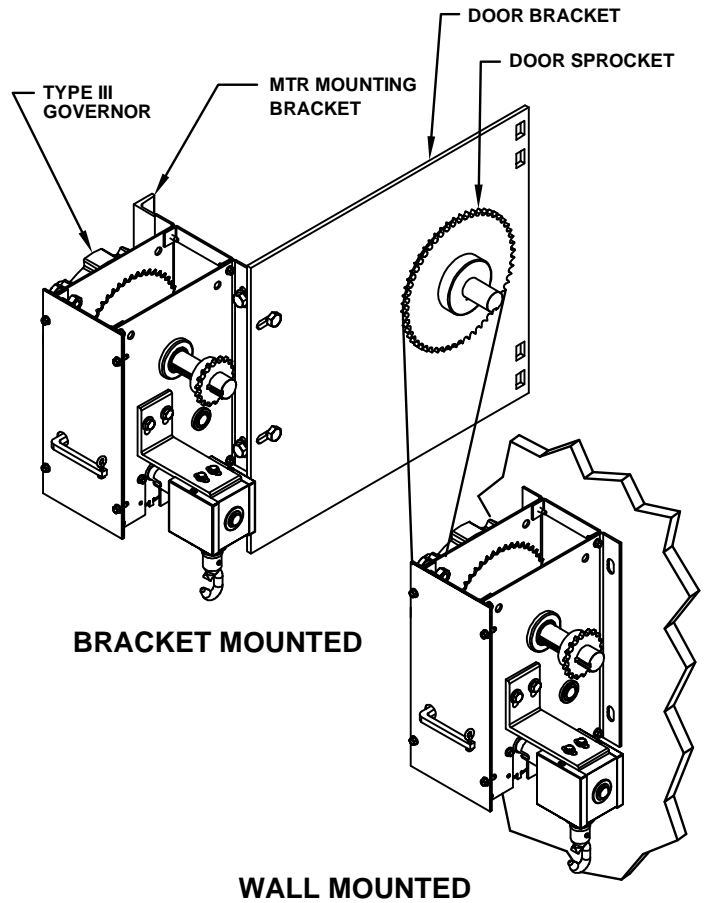

CRANK OPERATED

RIGHT HAND IS SHOWN - LEFT HAND IS OPPOSITE

CAUTION:

*DRIVE SPROCKET AND GOVERNOR(S) MUST BE KEYPED TO SHAFT.

FIG. 23

BARREL AND BRACKET ASSEMBLY FD-2A VERT MOUNT CHAIN OPERATED

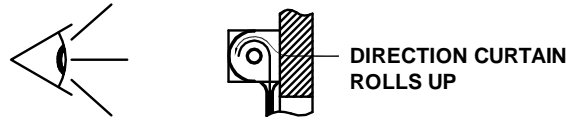
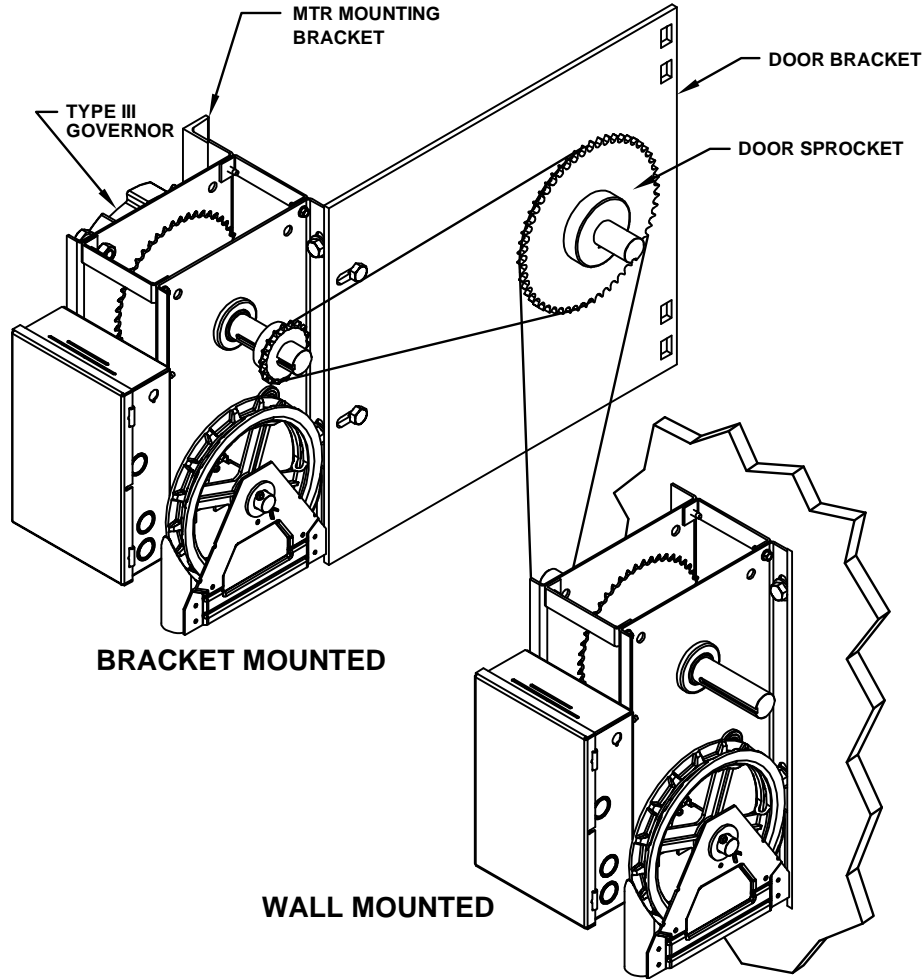
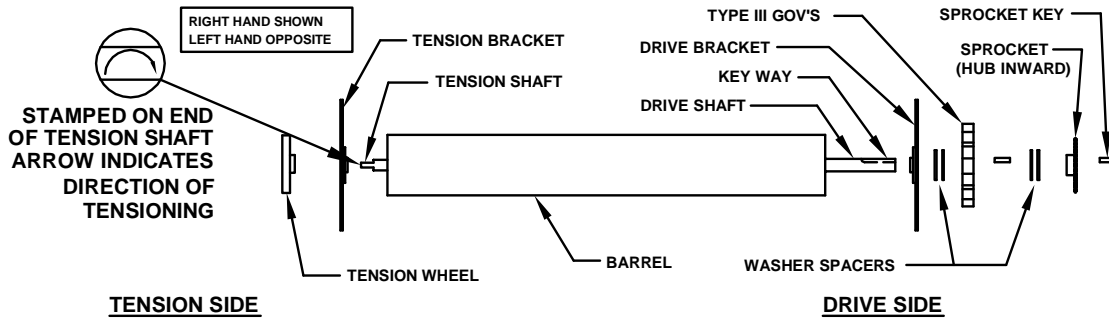

FIG. 24



RIGHT HAND IS SHOWN - LEFT HAND IS OPPOSITE

CAUTION:
*DRIVE SPROCKET AND GOVERNOR(S) MUST BE KEYED TO SHAFT.

FIG. 25

CURTAIN ASSEMBLY FOR SD / FD / OR GRILLE DOORS

IMPORTANT: Be sure the tension shaft is free to rotate. Do not install tension wheel at this time.

- 1) Place the rolled curtain below the Barrel Assembly. Hoist the curtain approx. 3 Ft below the barrel and suspend it there by means of two or more slings.

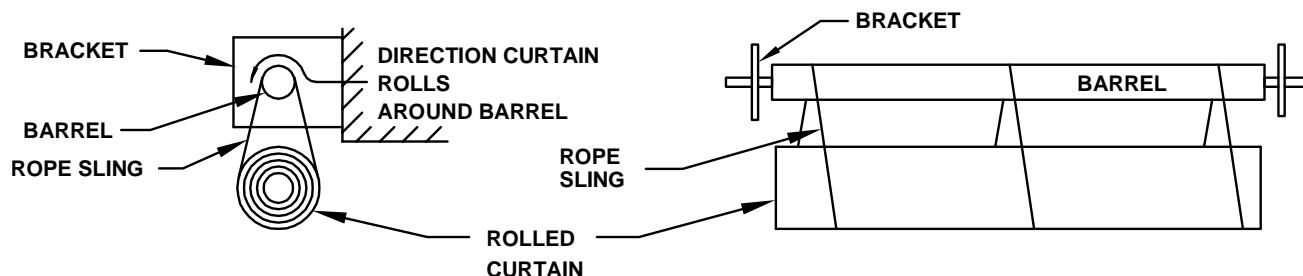

FIG 26

- 2) Using slings tied through the center hole of the top slat of the curtain; wrap the slings around the barrel in the direction of coil up rotation, pull the top slat up around the barrel. If hoops are used, place in line with the holes in the top slat, and with the top slat lined up straight on the barrel, secure the hoops to the barrel.
- 3) **IMPORTANT: BE SURE THE ENDS OF THE CURTAIN ARE EQUIDISTANT FROM THE INSIDE FACES OF THE BRACKETS.**
- 4) If your door has a means of manually operating, use it to roll the curtain onto the barrel.
- 5) If you door is the push up type, use a tensioning bar inserted into the tension wheel to rotate the barrel while rolling the curtain onto the barrel. Rotate the tension wheel in the same direction the barrel turns when the curtain coils onto it.
- 6) With the curtain completely rolled onto the barrel, feed the bottom bar into the guides and attach the stops as shown in FIG 27.

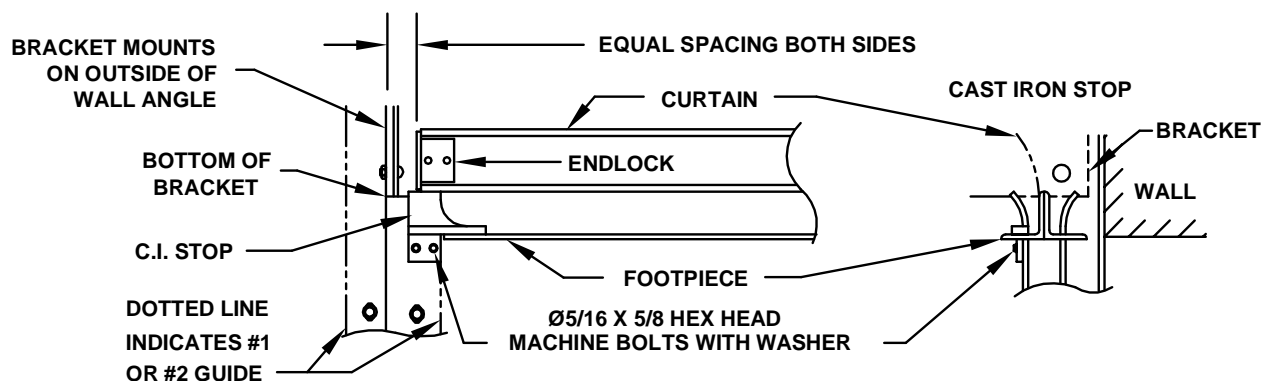
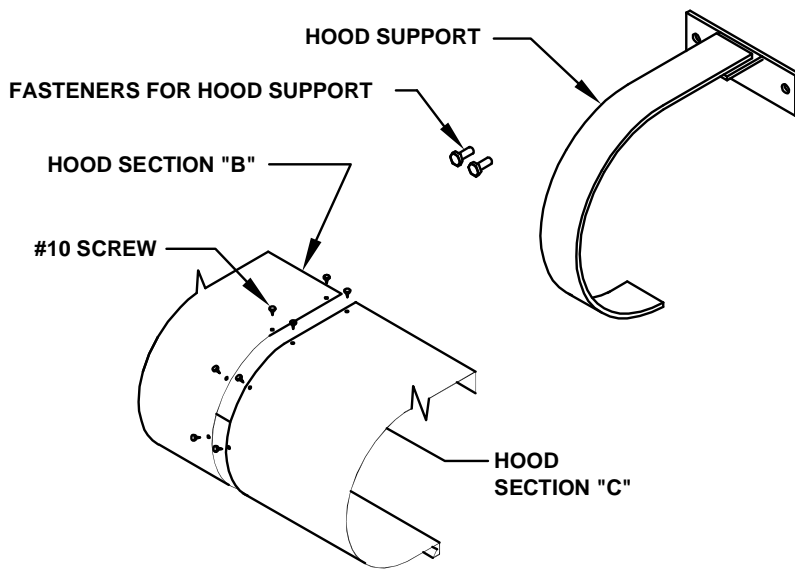
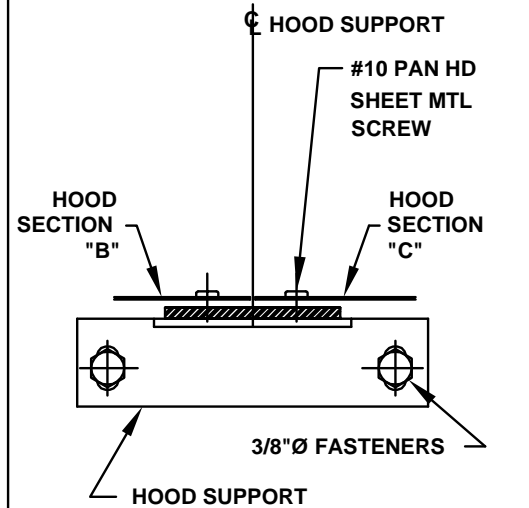

FIG 27

HOOD SUPPORT MOUNTING INSTRUCTION



MULTI-SECTION HOOD ASSEMBLY



SECTION THRU HOOD SUPPORT

FIG 28

FIG 29

Assembly Multi Section Hood:

- 1) Verify support size by comparing to Bracket Plate Hood Band.
- 2) Locate support as per Table 2.
- 3) Layout and drill wall for 3/8" hood support bolts (2 bolts per support) and attach hood support(s) to wall.
- 4) With the hood sections over the support, butt hood ends together, and center on the hood support(s). Cope ends of top flange if required.
- 5) Drill .157" hole thru the hood and support. Fasten together with the #10 pan head self-tapping machine screws provided. Note: Screws should not interfere w/curtain; Verify.

TABLE 1

ITEM NUMBER	MOUNTING MATERIAL	DRILL SIZE	DRILL DEPTH	TAP SIZE	INSERT	MOUNTING BOLT
1 (TABLE 3)	MASONRY	3/8" CARBIDE	2"		3/8" WEDGE ANCH.	
2 (TABLE 3)	WOOD	3/16"Ø	1"			3/8" X 2" LAG
3 (TABLE 3)	STEEL	5/16"Ø	1"	3/8"-16		3/8" X 1" HHMB

TABLE 2

HOOD LENGTH	SECTIONS	SUPPORTS	LOCATION
0 TO 14'-0"	1	0	
14'-0 1/8" TO 28'-0"	2	1	CENTER OF HOOD
28'-0 1/8" TO 42'-0"	3	2	AT 1/3 POINTS
42'-0 1/8" TO 56'-0"	4	3	AT 1/4 POINTS

TABLE 3

ITEM NO.	PART NO.	DESCRIPTION
1	3-2210-01	ANCHOR WEDGE 3/8 X 2-1/4.
2	3-2120-01	SCREW LAG 3/8 X 2 STL PL.
3	3-2150-11	BOLT HHMB 3/8 X 1 PL.

HOOD INSTALLATION

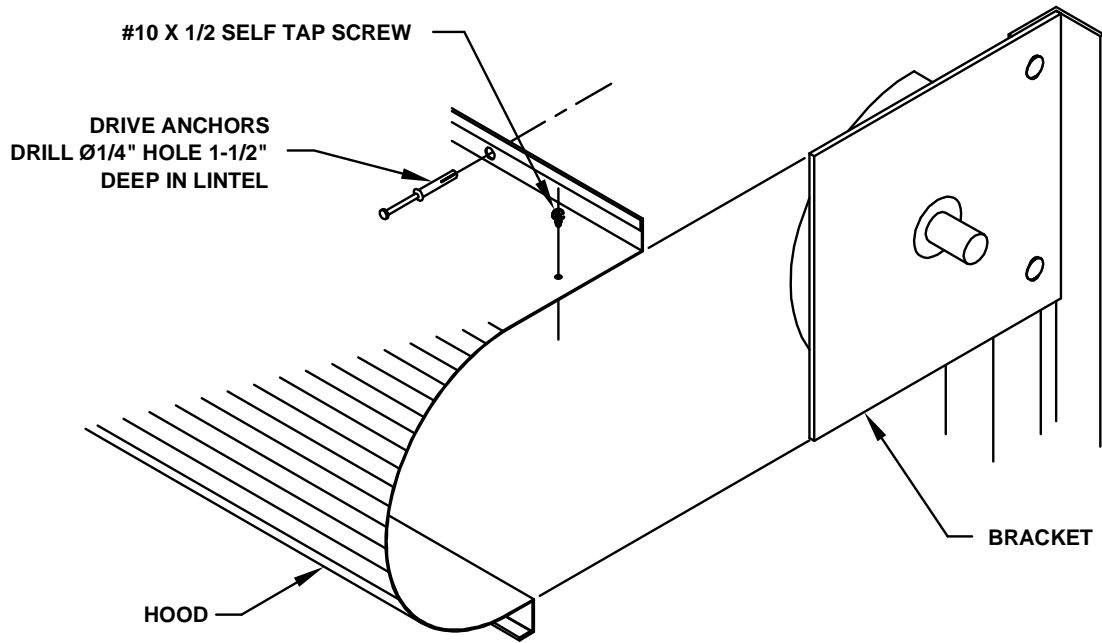

FIG 30

SERVICE/FIRE DOORS HOOD FLANGE UP

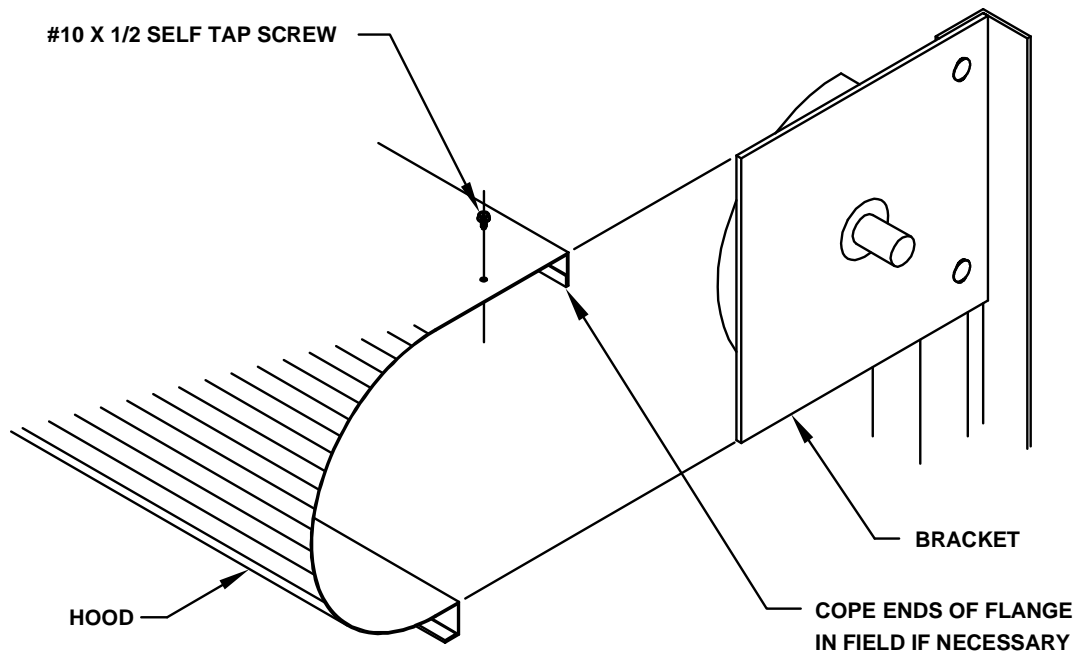

FIG 32

SERVICE/FIRE DOORS HOOD FLANGE DOWN

FIRE DOORS TENSIONING INSTRUCTIONS

SINGLE SPRING/GOVERNOR - PUSH UP MANUAL OPERATION



IMPORTANT

DO NOT ATTEMPT TO MAKE ANY ADJUSTMENT TO THE TENSION ASSEMBLY WITH THE CURTAIN IN ANY POSITION OTHER THAN FULLY COILED ON THE BARREL (DOOR OPEN). WINDING BARS SHOULD BE A MINIMUM OF 3/8 SOLID STEEL ROD, 2 TO 3 FEET LONG. DO NOT USE PIPE OR CONDUIT.

- 1) To charge the counterbalance spring, the curtain is to be in the raised position with the bottom bar positioned approximately 6" below the guide stops (or flat bar stops if provided). Now place a clamp across the throat of the door's guide to prevent the curtain from drifting to the closed position.
- 2) Install adjusting wheel on the end of the drive/governor shaft.
- 3) With the release arm in the disengaged position, rotate the adjusting wheel in the direction the barrel rotates when coiling the curtain on barrel. The shaft is to be rotated until the bottom bar raises up to the guide stops and remains in that position. For optimum operation, you may find more turns are required, or in some cases, less turns are required.

IMPORTANT:

UNDER NO CIRCUMSTANCES SHOULD MORE THAN ONE FULL TURN BE ADDED OVER THAT WHICH IS REQUIRED TO HOLD THE CURTAIN'S BOTTOM BAR AT THE GUIDE STOPS.

- 4) Finally, make sure the governor pawl is held in the disengaged position. (See FIG 32)
- 5) The door is now properly set and ready to test. Test the door for normal operation.
- 6) After normal operation tests have been made, it remains to test the automatic close feature. Proceed as follows:
- 7) With door in the full open position, drop the release arm. The arm will drop, disengaging the adjusting wheel, releasing the drive/governor counterbalance spring. (Simultaneously, the pawl will rotate downward and engage the governor). The door should now descend to the fully closed position.
- 8) The closing time should approximate an average closing speed of 6" to 2 feet per second. Refer to appropriate troubleshooting section.
- 9) If the closing velocity greatly exceeds the average speed of 2 feet per second, contact Customer Service for further instruction. When contacting us, be sure to advise the time it took in seconds for the door to close.
- 10) To reset the door, see reset instruction in FIG 32.
- 11) Connect fuse link system to release arm.

FIRE DOORS TENSIONING INSTRUCTIONS

DUAL SPRING - PUSHUP MANUAL OPERATION



DO NOT ATTEMPT TO MAKE ANY ADJUSTMENT TO THE TENSION ASSEMBLY WITH THE CURTAIN IN ANY POSITION OTHER THAN FULLY COILED ON THE BARREL (DOOR OPEN). WINDING BARS SHOULD BE A MINIMUM OF 3/8 SOLID STEEL ROD, 2 TO 3 FEET LONG. DO NOT USE PIPE OR CONDUIT.

- 1) To charge the counterbalance spring, the curtain is to be in the raised position with the bottom bar positioned approximately 6" below the guide stops (or flat bar stops if provided). Now, place a "C" clamp across the throat of the door's guide to prevent the curtain from drifting to the closed position.
- 2) NOW APPLY TENSION TO THE TENSION SIDE COUNTERBALANCING SPRING. ROTATE THE WHEEL IN THE SAME DIRECTION THE CURTAIN NORMALLY WINDS ONTO THE BARREL. SEE INSTALLATION INFORMATION SHEET FOR NUMBER OF TURNS. LOCK THE TENSION WHEEL IN PLACE TO THE TENSION BRACKET.
- 3) With the release arm in the disengaged position, rotate the adjusting wheel in the direction the barrel rotates when coiling the curtain on barrel. The shaft is to be rotated until the bottom bar raises up to the guide stops and remains in that position. For optimum operation, you may find more turns are required, or in some cases, less turns are required.

IMPORTANT:

UNDER NO CIRCUMSTANCES SHOULD MORE THAN ONE FULL TURN BE ADDED OVER THAT WHICH IS REQUIRED TO HOLD THE CURTAIN'S BOTTOM BAR AT THE GUIDE STOPS.

- 4) Finally, make sure the governor pawl is held in the disengaged position. (See FIG 32)
- 5) The door is now properly set and ready to test. Test the door for normal operation.
- 6) After normal operation tests have been made, it remains to test the automatic close feature. Proceed as follows:
- 7) With door in the full open position, drop the release arm. The arm will drop, disengaging the adjusting wheel, releasing the drive/governor counterbalance spring. (Simultaneously, the pawl will rotate downward and engage the governor). The door should now descend to the fully closed position.
- 8) The closing time should approximate an average closing speed of 6" to 2 ft. per second.
- 9) Door Speed Adjustment: (AUTOMATIC CLOSING MODE)
If the door drops faster than 24" per second, ADD tension to the tension side counterbalance spring. Add only one hole (in tension wheel) at a time and up to a maximum of two holes.
If the door drops slower than 6" per second, DECREASE the amount of tension to the tension side counterbalance spring. Decrease one hole (in tension wheel) at a time and up to a maximum of two holes.
If after making the above adjustments the closing speed still exceeds 2 feet per second or is less than 6" per second, contact Customer Service for further instructions. When contacting us, be sure to advise the time it took, in seconds, for the door to close. Also advise the number of initial turns of tension applied and any adjustments that were made.
- 10) To reset the door, see reset instruction in FIG 32.
- 11) Connect fuse link system to release arm.

FIRE DOORS TENSIONING INSTRUCTIONS

SINGLE SPRING/GOVERNOR - MANUAL OPERATION



IMPORTANT

DO NOT ATTEMPT TO MAKE ANY ADJUSTMENT TO THE TENSION ASSEMBLY WITH THE CURTAIN IN ANY POSITION OTHER THAN FULLY COILED ON THE BARREL (DOOR OPEN). WINDING BARS SHOULD BE A MINIMUM OF 3/8 SOLID STEEL ROD, 2 TO 3 FEET LONG. DO NOT USE PIPE OR CONDUIT.

- 1) To charge the counterbalance spring, the curtain is to be in the raised position with the bottom bar positioned approximately 6" below the guide stops (or flat bar stops if provided). Now place a clamp across the throat of the door's guide to prevent the curtain from drifting to the closed position.
- 2) Install adjusting wheel on the squared end of the drive/governor shaft and connect release arm to the fuse link system per drawing on FIG 38.
- 3) With a wrench gripped to the squared end of the drive/governor shaft and the release arm in the engaged position, rotate the shaft in the direction the barrel rotates when coiling the curtain on barrel. The shaft is to be rotated until the bottom bar raises up to the guide stops and remains in that position. For optimum operation, you may find more turns are required, or in some cases, less turns are required.

IMPORTANT:

UNDER NO CIRCUMSTANCES SHOULD MORE THAN ONE FULL TURN BE ADDED OVER THAT WHICH IS REQUIRED TO HOLD THE CURTAIN'S BOTTOM BAR AT THE GUIDE STOPS.

- 4) The door is now properly set and ready to test. Test the door for normal operation.
- 5) After normal operation tests have been made, it remains to test the automatic close feature. Proceed as follows:
- 6) With door in the full open position, drop the release arm. The cradle arm will drop allowing engagement of the "governor" and at the same time, disengaging the "yoke" from the adjusting wheel, releasing the drive/governor counterbalance spring. The door should now descend to the fully closed position.
- 7) The closing time should approximate an average closing speed of 6" to 2 feet per second. Refer to appropriate troubleshooting section.
- 8) If the closing velocity greatly exceeds the average speed of 2 feet per second, contact Customer Service for further instruction. When contacting us, be sure to advise the time it took in seconds for the door to close.
- 9) To reset the door, see reset instruction in FIG 33.
- 10) Connect fuse link system to release arm as shown in FIG 38.

FIRE DOORS TENSIONING INSTRUCTIONS

DUAL SPRING - MANUAL OPERATION



IMPORTANT

DO NOT ATTEMPT TO MAKE ANY ADJUSTMENT TO THE TENSION ASSEMBLY WITH THE CURTAIN IN ANY POSITION OTHER THAN FULLY COILED ON THE BARREL (DOOR OPEN). WINDING BARS SHOULD BE A MINIMUM OF 3/8 SOLID STEEL ROD, 2 TO 3 FEET LONG. DO NOT USE PIPE OR CONDUIT.

- 1) To charge the counterbalance spring, the curtain is to be in the raised position with the bottom bar positioned approximately 6" below the guide stops (or flat bar stops if provided). Now, place a "C" clamp across the throat of the door's guide to prevent the curtain from drifting to the closed position.
- 2) NOW APPLY TENSION TO THE TENSION SIDE COUNTERBALANCING SPRING. ROTATE THE WHEEL IN THE SAME DIRECTION THE CURTAIN NORMALLY WINDS ONTO THE BARREL. SEE INSTALLATION INFORMATION SHEET FOR NUMBER OF TURNS. LOCK THE TENSION WHEEL IN PLACE TO THE TENSION BRACKET.
- 3) Next, apply tension to the drive/governor counterbalancing spring. With the release arm in the engaged position, rotate the adjusting wheel in the direction the barrel rotates when coiling the curtain on the barrel. The adjusting wheel is to be rotated until the bottom bar raises up to the guide stops and remains in that position. For optimum operation you may find more turns are required, or in some cases less turns are required, on the drive/governor counterbalance spring.

IMPORTANT:

UNDER NO CIRCUMSTANCES SHOULD MORE THAN ONE FULL TURN BE ADDED OVER THAT WHICH IS REQUIRED TO HOLD THE CURTAIN'S BOTTOM BAR AT THE GUIDE STOPS.

- 4) The door is now properly set and ready to test. Test the door for normal operation.
- 5) After normal operation tests have been made, it remains to test the automatic close feature. Proceed as follows:
 - 6) With door in the full open position, drop the release arm. The cradle arm will drop allowing engagement of the "governor" and at the same time, disengaging the "yoke" from the adjusting wheel, releasing the drive/governor counterbalance spring. The door should now descend to the fully closed position.
 - 7) The closing time should approximate an average closing speed of 6" to 2 ft. per second.
 - 8) Door Speed Adjustment: (AUTOMATIC CLOSING MODE)

If the door drops faster than 24" per second, ADD tension to the tension side counterbalance spring. Add only one hole (in tension wheel) at a time and up to a maximum of two holes.

If the door drops slower than 6" per second, DECREASE the amount of tension to the tension side counterbalance spring. Decrease one hole (in tension wheel) at a time and up to a maximum of two holes.

If after making the above adjustments the closing speed still exceeds 2 feet per second or is less than 6" per second, contact Customer Service for further instructions. When contacting us, be sure to advise the time it took, in seconds, for the door to close. Also advise the number of initial turns of tension applied and any adjustments that were made.
 - 9) To reset the door, see reset instruction in FIG 33.
 - 10) Connect fuse link system to release arm as shown in FIG 38.

FIRE DOORS TENSIONING INSTRUCTIONS

MOTOR OPERATED



IMPORTANT

DO NOT ATTEMPT TO MAKE ANY ADJUSTMENT TO THE TENSION ASSEMBLY WITH THE CURTAIN IN ANY POSITION OTHER THAN FULLY COILED ON THE BARREL (DOOR OPEN). WINDING BARS SHOULD BE A MINIMUM OF 3/8 SOLID STEEL ROD, 2 TO 3 FEET LONG. DO NOT USE PIPE OR CONDUIT.

- 1) To charge the counterbalance spring, the curtain is to be in the raised position with the bottom bar positioned approximately 6" below the guide stops (or flat bar stops if provided). Now, place a clamp across the throat of the door's guide to prevent the curtain from drifting to the closed position.
- 2) NOW APPLY TENSION TO THE TENSION SIDE COUNTERBALANCING SPRING. ROTATE THE WHEEL IN THE SAME DIRECTION THE CURTAIN NORMALLY WINDS ONTO THE BARREL. SEE INSTALLATION INFORMATION SHEET FOR NUMBER OF TURNS. LOCK THE TENSION WHEEL IN PLACE TO THE TENSION BRACKET.
- 3) Test the door for normal operation.
- 4) After normal operation tests have been made, it remains to test the automatic close feature. Proceed as follows:
- 5) With door in the full open position, drop the release arm. The cradle arm will drop allowing engagement of the "governor" and disengage the motor from the drive system. The door will now descend to the fully closed position.
- 6) The closing time should approximate an average closing speed of 6" to 2 ft. per second.
- 7) Door Speed Adjustment: (AUTOMATIC CLOSING MODE)
If the door drops faster than 24" per second, ADD tension to the tension side counterbalance spring. Add only one hole (in tension wheel) at a time and up to a maximum of two holes.
If the door drops slower than 6" per second, DECREASE the amount of tension to the tension side counterbalance spring. Decrease one hole (in tension wheel) at a time and up to a maximum of two holes.
If after making the above adjustments the closing speed still exceeds 2 feet per second or is less than 6" per second, contact Customer Service for further instructions. When contacting us, be sure to advise the time it took, in seconds, for the door to close. Also advise the number of initial turns of tension applied and any adjustments that were made.
- 8) To reset the door, see reset instruction in FIG 34.
- 9) Connect fuse link system to release arm as shown in FIG 38.

FIRE DOORS TENSIONING INSTRUCTIONS

COMPOUND MOTOR OPERATED OR

COMPOUND CHAIN OPERATED



IMPORTANT

DO NOT ATTEMPT TO MAKE ANY ADJUSTMENT TO THE TENSION ASSEMBLY WITH THE CURTAIN IN ANY POSITION OTHER THAN FULLY COILED ON THE BARREL (DOOR OPEN). WINDING BARS SHOULD BE A MINIMUM OF 3/8 SOLID STEEL ROD, 2 TO 3 FEET LONG. DO NOT USE PIPE OR CONDUIT.

- 1) To charge the counterbalance spring, the curtain is to be in the raised position with the bottom bar positioned approximately 6" below the guide stops (or flat bar stops if provided). Place a clamp across the throat of the door's guide to prevent the curtain from drifting to the closed position.
- 2) Rotate the tension wheel in the direction the curtain normally winds onto the barrel. See the Installation Information Sheet for the number of turns. Now lock the tension wheel in place to the bracket.
- 3) Test the door for normal operation.
- 4) After normal operation tests have been made, it remains to test the automatic close feature. Proceed as follows:
- 5) With the door in the full open position drop the release arm. The cradle arm will drop allowing the "pallet" to engage the "scape wheel" and disengage the motor from the drive system. The door will now descend to the fully closed position.
- 6) The closing time should approximate an average closing speed of 2 feet per second.
- 7) If the closing velocity greatly exceeds the average speed of 2 feet per second, and after counterbalance spring adjustments have been made, contact Customer Service for further instruction. When contacting us, be sure to advise the time it took in seconds for the door to close, and the number of turns of initial tension applied.
- 8) To reset the door, see reset instruction in FIG 34.
- 9) Connect the fuse link system to the release arm as shown in FIG 38.

FIRE DOORS TENSIONING INSTRUCTIONS FDO MOTOR OPERATED

- 1) Install the motor operator on the bracket. Connect the roller chain from the motor sprocket to the drive sprocket on the barrel shaft. Wire the operator per the wiring diagram provided.
- 2) To charge the counterbalance spring, the curtain is to be in the raised position with the bottom bar positioned approximately 6" below the guide stops. Place a "C" clamp across the throat of the door's guide to prevent the curtain from drifting to the closed position.
- 3) Now apply tension to the counterbalance spring. Rotate the wheel in the same direction that the curtain normally winds onto the barrel. **SEE THE INSTALLATION INFORMATION SHEET FOR THE NUMBER OF TURNS REQUIRED.** Lock the tension wheel in place to the tension bracket.
- 4) Set the limit switches. See the instructions for setting the limit switches on page 33.
- 5) Test the door for normal operation. Check the top and bottom limit switches and the safety edge operation.
- 6) After normal operation tests have been made, it remains to test the automatic close feature. Follow procedure outlined in motor operator owners manual.



IMPORTANT

DO NOT ATTEMPT TO MAKE ANY ADJUSTMENT TO THE TENSION ASSEMBLY WITH THE CURTAIN IN ANY POSITION OTHER THAN FULLY COILED ON THE BARREL (DOOR OPEN). WINDING BARS SHOULD BE A MINIMUM OF 3/8 SOLID STEEL ROD, 2 TO 3 FEET LONG. DO NOT USE PIPE OR CONDUIT.

FIRE DOORS TENSIONING INSTRUCTIONS FD-2A CHAIN OPERATED

- 1) To charge the counterbalance spring, the curtain is to be in the raised position with the bottom bar positioned approximately 6" below the guide stops. Place a "C" clamp across the throat of the door's guide to prevent the curtain from drifting to the closed position.
- 2) Now apply tension to the counterbalance spring. Rotate the wheel in the same direction that the curtain normally winds onto the barrel. **SEE THE TABLE ON THE FRONT SHEET FOR THE NUMBER OF TURNS REQUIRED.** Lock the tension wheel in place to the tension bracket.
- 3) Test the door for normal operation.
- 4) Recheck drive chain tension and adjust as necessary.
- 5) After normal operation tests have been made, it remains to test the automatic close feature.

AUTOMATIC CLOSE TESTING PROCEDURE

- 1) Open door to fully open position.
- 2) Verify that the pawl is engaged on the viscous governor and that the key is installed between governor & shaft.
- 3) Verify wiring per diagram.
- 4) Activate initiating device (smoke detector / fire alarm) unit should no longer be receiving 120VAC power after activation.
- 5) Clutch mechanism will disengage allowing the door to descend governed by the viscous governor.
- 6) Once door has reached the fully closed position deactivate the smoke detector / fire alarm. Power should now be restored to the unit.
- 7) After a 30 second delay, begin pulling hoist hand chain to raise the door. The hoist will freewheel at first until the clutch reengages.

FIRE DOORS RESETTING INSTRUCTIONS

MANUAL PUSH UP OPERATION

CAUTION: ONLY TRAINED PERSONNEL SHOULD RESET FIRE DOORS

- 1) Curtain is to be in the raised position with the bottom bar positioned approximately 6" below the guide stops. Now place a "c" clamp across the throat of the door's guides to prevent the curtain from drifting to the closed position.
- 2) With the release arm in the disengaged position, rotate the adjusting wheel in the direction the barrel rotates when coiling the curtain on barrel. The shaft is to be rotated until the bottom bar raises up to the guide stops and remains in that position.
- 3) Raise the release arm so that it completely engages the adjusting wheel.
- 4) Connect release arm to the fusible link system or other approved release device.
- 5) Gently pull pawl hold up rod away from bracket and rotate pawl to the disengaged position.

IMPORTANT:

UNDER NO CIRCUMSTANCES SHOULD MORE THAN ONE FULL TURN BE ADDED OVER THAT REQUIRED TO HOLD THE CURTAIN'S BOTTOM BAR AT THE GUIDE STOPS.

- 6) The door is now properly set and ready for normal operation.

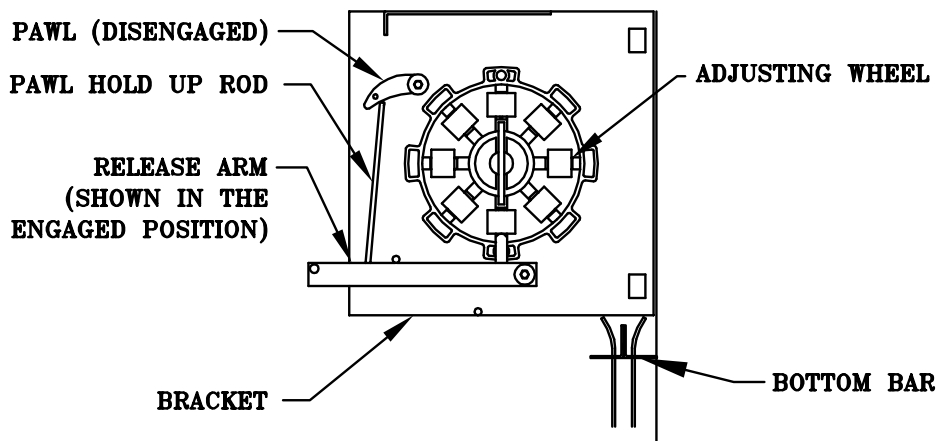

FIG 32

FIRE DOORS RESETTING INSTRUCTIONS

MANUAL OPERATION

CAUTION: ONLY TRAINED PERSONNEL SHOULD RESET FIRE DOORS

- 1) Raise the release arm to the engaged position. Connect release arm to the fusible link system or other approved release device.
- 2) Curtain is to be in the raised position with the bottom bar positioned approximately 6" below the guide stops. Now place a "c" clamp across the throat of the door's guides to prevent the curtain from drifting to the closed position.
- 3) With a wrench gripped to the squared end of the drive/governor shaft, rotate the shaft in the direction the barrel rotates when coiling the curtain on the barrel. The shaft is to be rotated until the bottom bar raises up to the guide stops and remains in that position.

IMPORTANT:

UNDER NO CIRCUMSTANCES SHOULD MORE THAN ONE FULL TURN BE ADDED OVER THAT REQUIRED TO HOLD THE CURTAIN'S BOTTOM BAR AT THE GUIDE STOPS.

- 4) The door is now properly set and ready for normal operation.

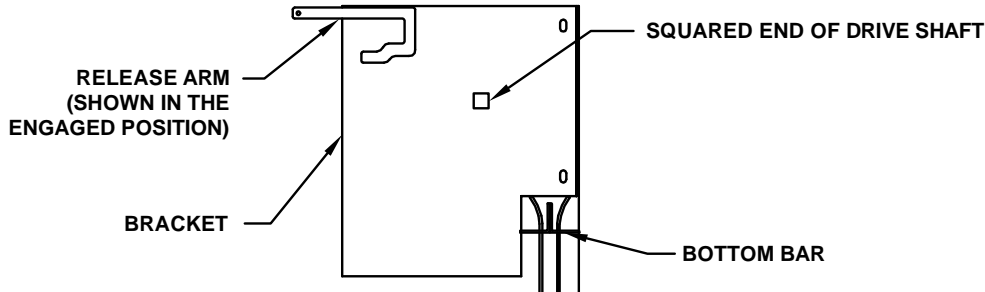

FIG 33

MOTOR OPERATION

CAUTION:

ONLY TRAINED PERSONNEL SHOULD RESET FIRE DOORS AND ADJUST THE LIMIT SWITCH.
ONLY ADJUST THE LIMIT SWITCH WITH THE POWER "OFF".

- 1) With the door closed by fire drop and the release arm in the disengaged position, activate the "close" control and allow the motor to run until it is stopped by the down limit switch.

CAUTION: THIS STEP IS CRITICAL. FAILING TO RUN MOTOR TO CLOSE WILL RESULT IN DAMAGE TO DOOR.

- 2) Raise the release arm to the engaged position. Connect the release arm to the fusible link system or other approved release device.
- 3) Activate the "open" control and allow the door to open. Stop the door by activating the "stop" control when the bottom bar is approximately 12" below the stops at top of the door.
- 4) Using manual operation, raise the door to approximately 3" below the stops.
- 5) Disconnect the power.
- 6) The up limit switch can now be identified as the one with the cam nut closest to it. Depress the locking plate and rotate the cam nut toward the limit switch until a "click" is heard. The UP limit is now set.
- 7) Re-connect the power.
- 8) Activate the "close" control and allow the door to close. Stop the door by activating the "stop" control when the bottom bar is approximately 12" above the floor.
- 9) Using manual operation, lower the door to approximately 3" above the floor.
- 10) Disconnect the power.
- 11) The down limit switch can now be identified as the one with the cam nut closest to it. Depress the locking plate and rotate the cam nut toward the limit switch until a "click" is heard. The DOWN limit is now set.
- 12) Re-connect the power.
- 13) Test the door operation at the top and bottom and fine adjust as desired.

CAUTION: DO NOT ALLOW THE MOTOR TO FORCE THE BOTTOM BAR AGAINST THE STOPS OR THE FLOOR.

- 14) Test entire door motor operation.

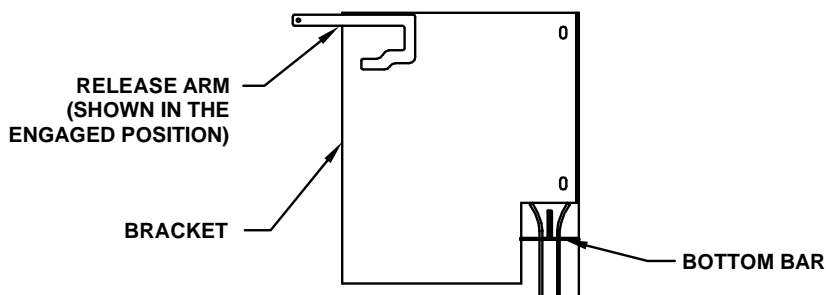

FIG 34

FIRE DOORS TROUBLE SHOOTING TYPE III - VIBRATECH GOVERNOR

GENERAL OPERATION

The Vibrattech governor is a viscous type governor. The shearing force in the viscous fluid creates braking torque. The faster the governor turns the more braking torque is created. While all governors are the same size different fluids are used to create more or less braking torque. On larger doors a tension spring is required to assist the vibrattech governor. The advantage of the vibrattech governor is that there is no mechanical wear and that bracket adjustments are not required.

TROUBLE SHOOTING:

ALL BRACKETS ARE FACTORY PRESET AND TESTED. THE FOLLOWING CHECKS SHOULD BE PERFORMED BEFORE ADJUSTING THE BRACKET.

- 1) If tension side spring is used verify initial turns.
- 2) Verify brackets are perpendicular to the barrel.
- 3) Verify curtain is not binding in guides.
- 4) Verify curtain endlocks are not rubbing bracket plate (Curtain shifted).
- 5) Verify that the vibrattech governor is keyed to the drive shaft.
- 6) Verify the pawl can rotate freely and fully engages cogs on governor.

FIRE DOORS TROUBLE SHOOTING

TYPE III - VIBRATECH GOVERNOR

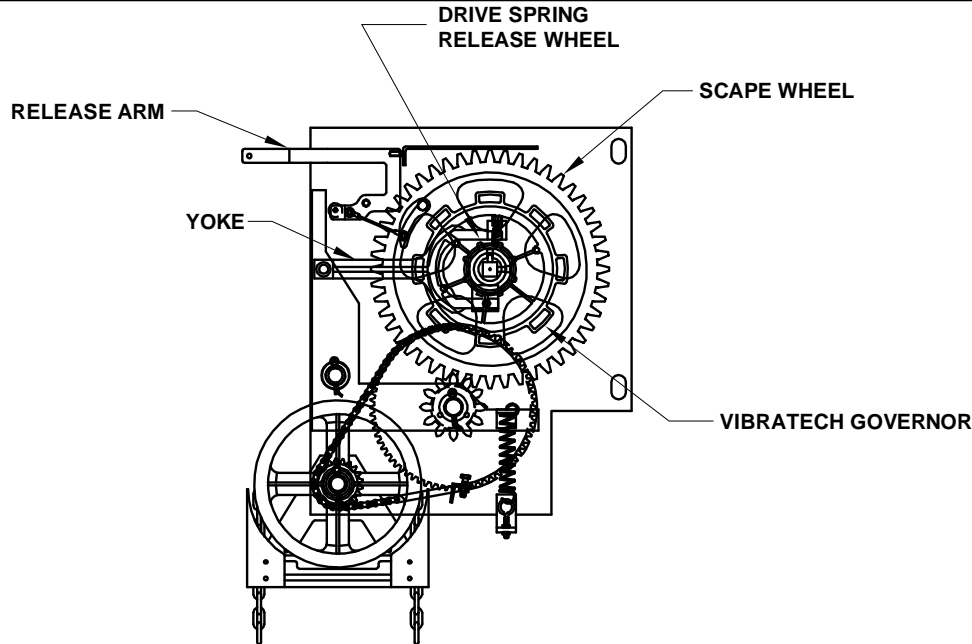

FIG 35

ADJUSTMENTS - DOOR CLOSING TOO FAST

- 1) Clamp door off 12-18" below the stops. Release the release arm and let the door rest on the clamps.
- 2) Raise door to the stops and release. Visually check to see that the pawl engages vibrattech and that vibrattech does not rotate as the door drops. If pawl does not engage check spring and cable assembly. If vibrattech rotates check key.
- 3) Add tension to tension side spring one click (hole) at a time until the average door speed is 6-18" per second.

DO NOT EXCEED RECOMMENDED INITIAL TENSION BY MORE THAN 1-1/2 FULL TURNS WITHOUT CONSULTING FACTORY.

- 4) If the acceptable average speed cannot be obtained stop and consult factory. Provide the following information to factory:

Job Number-

Door Mark-

Vibrattech Size - Found on Vibrattech Label (60, 100, 300)

Initial Turns - After adjustment procedure

Average Door Speed with Initial Turns

ADJUSTMENTS - DOOR CLOSING TOO SLOW

- 1) Raise the door to the open position.
- 2) Remove tension from tension side spring one click (hole) at a time until average door speed is 6-18" per second.

DO NOT APPLY NEGATIVE TURNS TO THE SPRING

- 3) If the acceptable average speed cannot be obtained stop and consult factory. Provide the following information to factory:

Job Number-

Door Mark-

Vibrattech Size - Found on Vibrattech Label (60, 100, 300)

Initial Turns - After adjustment procedure

Average Door Speed with Initial Turns

LOAD HOLDING BRAKE ADJUSTMENT COMPOUND CHAIN OPERATED

- 1) The Load Holding Brake comes from the factory pre-adjusted but may need some minor adjustments after the door has been installed.
- 2) After the door has been installed and the door has been properly tensioned according to the installation instructions, chain operate the door up and down a few times.
- 3) Prior to any adjustments to the Load Holding Brake, test the door in the "fire drop mode" to make sure that the door is properly set.
- 4) After the door has been "fire drop" tested, reset the door for normal operation. Chain operate the door up and down a few times. If the Load Holding Brake needs adjustment, see the chart below for the adjustment procedures.

BRAKE ADJUSTMENT GUIDE

PROBLEM	CAUSE	CORRECTION
A. The door drifts and will not hold at the stops in the open position or the door travels too fast during operation.	The Brake is set too loose.	Back off set screw "A" one full turn (counter clockwise) and tighten the jamb nut. Turn set screw "B" clockwise one full turn and tighten the jamb nut. Repeat if necessary.
B. The door operates too hard or jerks while operating.	The Brake is set too tight.	Turn set screw "A" clockwise one full turn and tighten the jamb nut. Back off set screw "B" one full turn (counter clockwise) and tighten the jamb nut. Repeat if necessary.

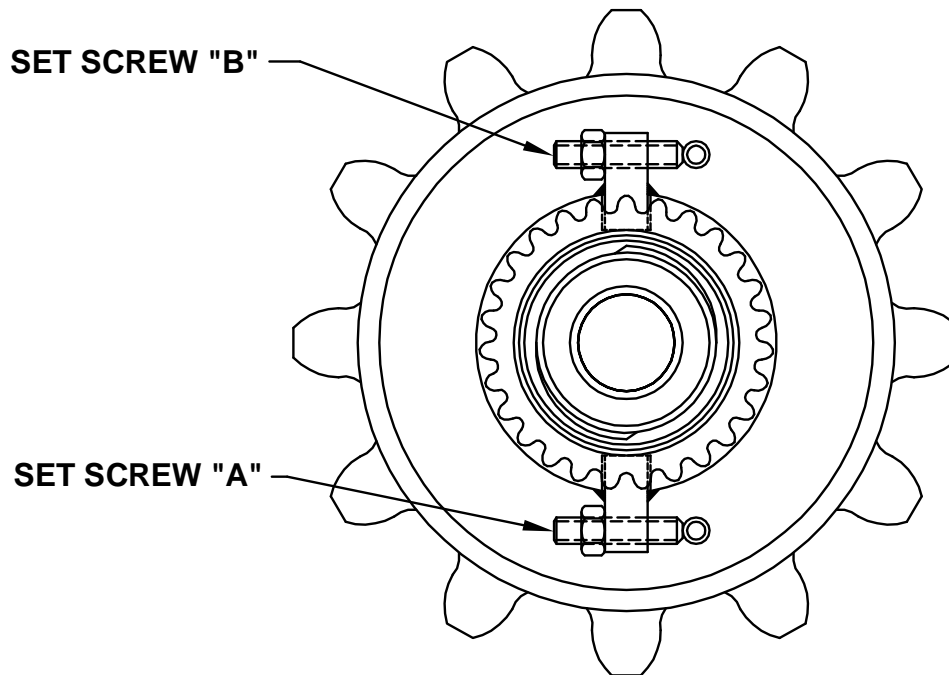
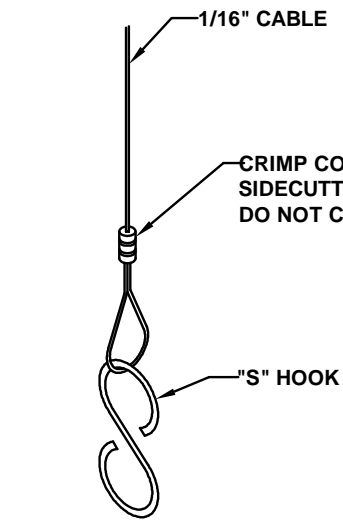
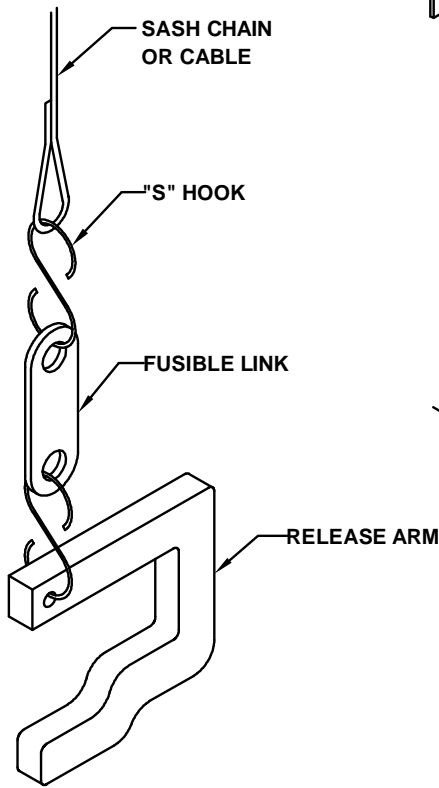

FIG. 36

FUSIBLE LINK SYSTEM



CABLE END DETAIL



DETAIL A

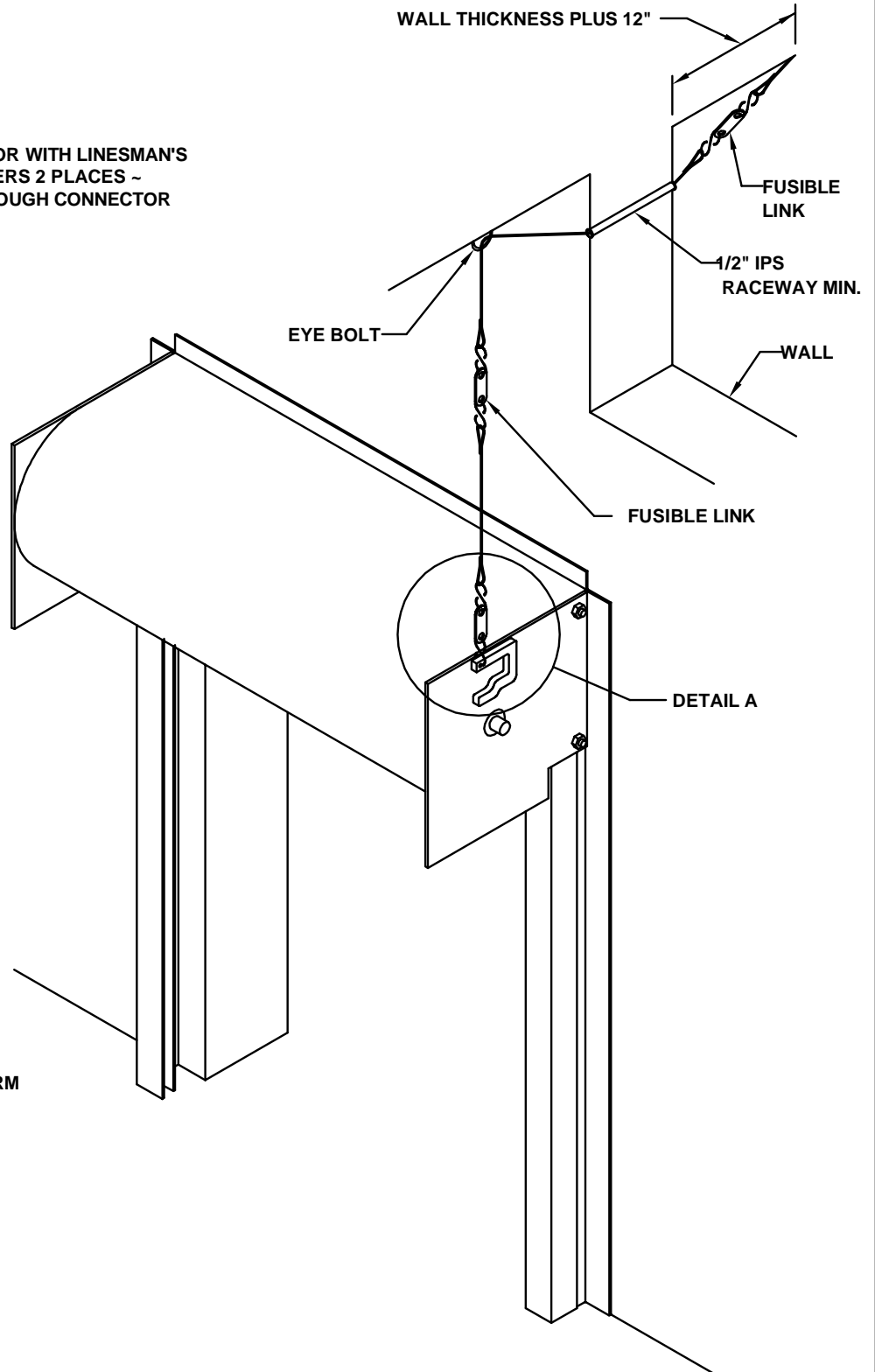

* THIS FUSIBLE LINK ARRANGEMENT IS FOR SINGLE FIRE DOORS WITH ONE RELEASE ARM.

* CONSULT N.F.P.A. BULLETIN 80 FOR ADDITIONAL INFORMATION.

FIG 37

INSTRUCTIONS FOR SETTING ROTARY LIMIT SWITCH

**CAUTION: ONLY ADJUST THE ROTARY LIMIT SWITCH WITH THE POWER "OFF".
ONLY TRAINED PERSONNEL SHOULD SET OR ADJUST THE LIMIT SWITCH.**

- 1) Using the manual operator, lower or raise the curtain to the midpoint of the opening.
- 2) Open the limit switch box and identify all parts. **(A) DETENT PLATE (B) CAM NUT (C) BASIC SWITCHES**
- 3) Depress the spring loaded detent plate and rotate each cam nut approximately 1/8" from the basic switches as shown below.

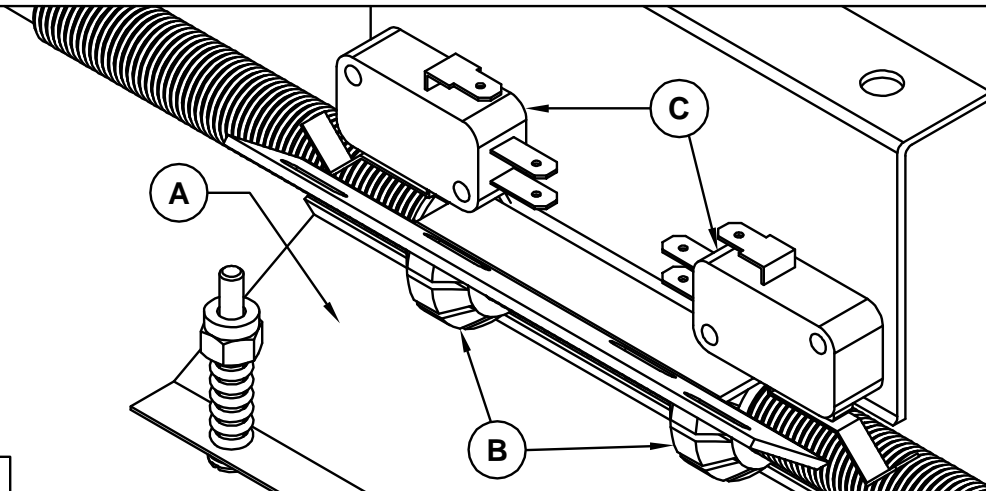

FIG 38

- 4) Apply power to the motor and test the operation of the door. As the door is opening the "open" cam nut should be traveling towards the "open" basic switch. As the door is closing the "close" cam nut should be traveling towards the "close" basic switch. The cam nuts are designed to activate the basic switches and terminate the travel of the door.
- 5) **IMPORTANT:** Check that the motor is correctly wired in regards to rotation and direction. Operate the open and close functions. If the mode of operation is incorrect (when the "open" functions of the control station makes the door close or the "close" functions of the control station makes the door open) or the rotation direction of the cam nut is incorrect (cam nut travels toward the "open" basic switch when closing and the "close" basic switch when opening) discontinue operation of the door and check the wiring. All wiring must be correct before proceeding.
- 6) Once the correct rotation and orientation of the control functions and basic switches has been determined, proceed with the finalized setting of the rotary limit switch.
- 7) Turn power off. With the manual operator lower the door to the fully closed position. Rotate the "close" cam nut toward the "close" basic switch until the switch clicks. The "close" basic switch is now set. Raise the door to the fully open position. Rotate the "open" cam nut toward the "open" basic switch until the switch clicks. The open basic switch is now set.
- 8) Make sure that the detent plate is fully engaged in the slots of each cam nut, replace the cover on the limit switch and apply power to the motor operator to test the operation of the door. If further fine tuning adjustments are required make sure that the power is off before adjustments are made.

SAFETY EDGE COIL CORD/ CORD REEL INSTALLATION INSIDE DOOR WITH MOTOR MOUNTED CONTROLLER

COIL CORD INSTALLATION INSTRUCTIONS:

- 1) LOCATE CONTROL PANEL KNOCK OUT CLOSEST TO DOOR OPENING & IN LINE WITH MALE CONNECTOR,
- 2) LOCATE COIL CORD/CORD REEL AS NOT TO INTERFERE WITH ROLLER CHAIN.
- 3) INSTALL ELBOW (AS SHOWN).
- 4) WIRE TO TERMINALS AS INDICATED ON WIRING DIAGRAM.
- 5) CONNECT TWIST LOCK PLUG (WIRE FEMALE TO COIL CORD/CORD REEL IF SHIPPED LOOSE).
- 6) TEST REVERSING BOTTOM BAR FOR CORRECT OPERATION.
- 7) ADJUST FEATHEREDGE SWITCH AS REQ'D. (SEE INSTRUCTIONS ON PAGE 35)

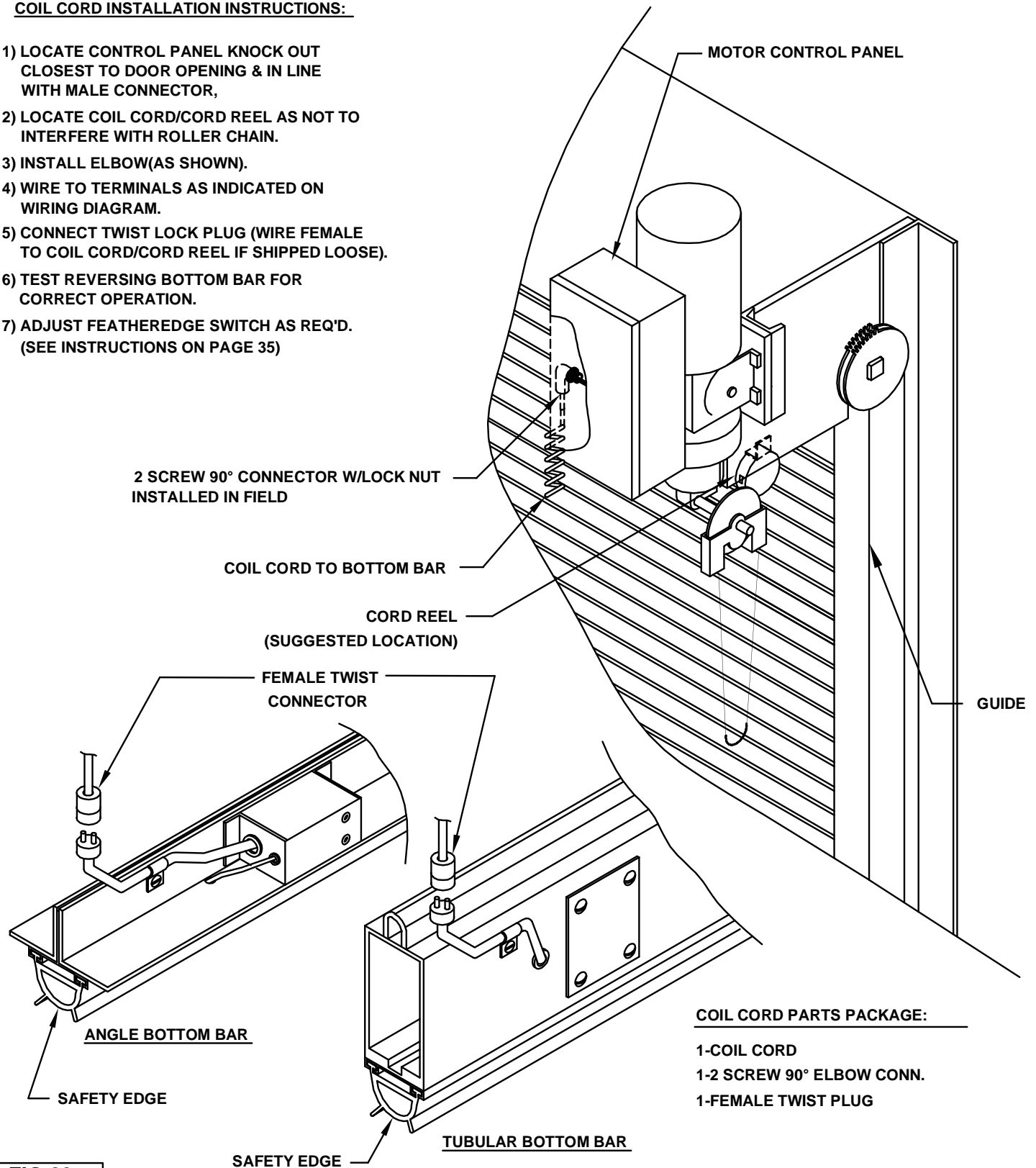

FIG 39

SAFETY EDGE COIL CORD/ CORD REEL INSTALLATION OUTSIDE AND ABOVE MOUNTED DOORS

MOTOR SHOWN RECTANGULAR & DOTTED FOR CLARITY
THE CONDUIT FROM THE CONDUIT BOX TO THE
CONTROLLER IS TO BE DONE IN FIELD

COIL CORD OPTION:
2 X 4 CONDUIT BOX

CORD REEL OPTION:
CONDUIT BOX W/2 PRG
OUTLET TO BE SUPPLIED
BY OTHERS.

COIL CORD/CORD REEL INSTALLATION:

- 1) FASTEN CONDUIT BOX W/MTG PLATE TO WALL AS SHOWN USING $\varnothing 1/4$ FASTENERS.
- 2) INSTALL 2 SCREW 90° ELBOW AS SHOWN IF USING COIL CORD.
- 3) WIRE COIL CORD/CORD REEL AS INDICATED ON WIRING DIAGRAM.
- 4) CONNECT TWIST LOCK PLUG (WIRE FEMALE TO COIL CORD/CORD REEL IF SHIPPED LOOSE).
- 5) TEST REVERSING BOTTOM BAR FOR CORRECT OPERATION.
- 6) ADJUST FEATHEREDGE SWITCH AS REQ'D (SEE INST. ON PAGE 35)

USE (2) #12 PAN HD
SCREW W/SHIELDS FOR
MASONRY MTG.

CORD REEL

CORD REEL (SUGGESTED LOCATION)
SEE ABOVE DETAIL

COIL CORD PARTS PACKAGE:

- 1 - COIL CORD
- 2 - 2 SCREW 90° ELBOW
- 3 - FEMALE TWIST LOCK PLUG

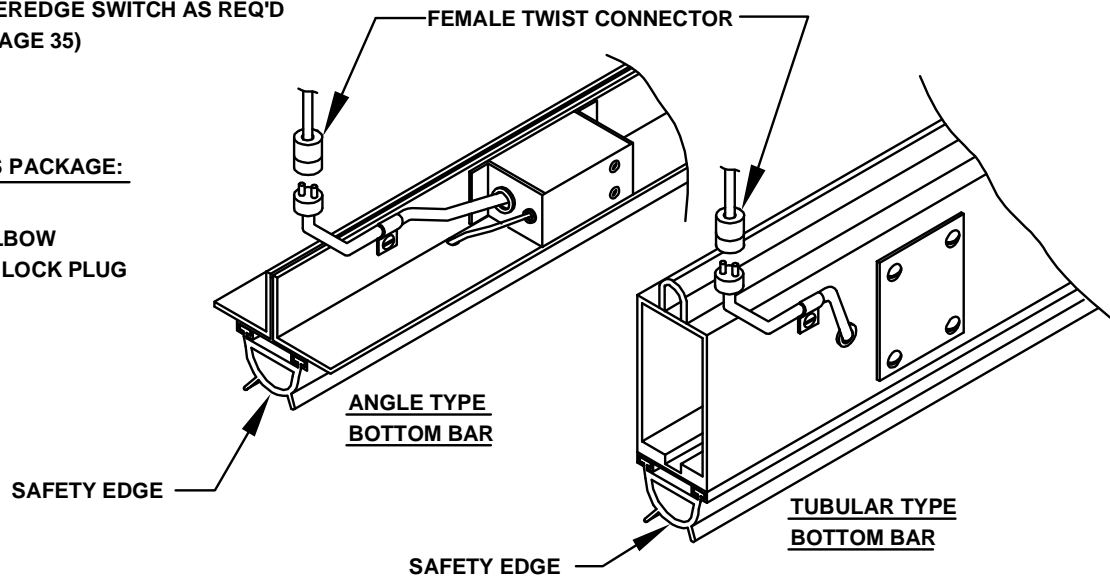

FIG 40

FAILSAFE SAFETY EDGE INSTALLATION INSTRUCTIONS

FAILSAFE INSTRUCTIONS:

NOTE: DIODE IS PROVIDED PREWIRED INSIDE OF BOTTOM BAR. IF MOTOR MANUFACTURER HAS PROVIDED A DIODE SAVE AS A SPARE.

- 1) LOCATE CONTROL PANEL KNOCK OUT CLOSEST TO DOOR OPENING & IN LINE WITH MALE CONNECTOR.
- 2) LOCATE COIL CORD/CORD REEL AS NOT TO INTERFERE WITH ROLLER CHAIN.
- 3) WIRE TO TERMINALS AS INDICATED ON WIRING DIAGRAM. (NOTE: DIODE CONNECTION IS PREWIRED)
- 4) CONNECT TWIST LOCK PLUG. (WIRE FEMALE TO COIL CORD/CORD REEL IF SHIPPED LOOSE)
- 5) TEST REVERSING BOTTOM BAR FOR CORRECT OPERATION.
- 6) IF MOTOR DOES NOT OPERATE OR FAILSAFE RELAY SHOWS A FAULT CONDITION REVERSE POLARITY OF WIRES IN CONTROLLER. DO NOT MODIFY DIODE CONNECTION ON BOTTOM BAR.

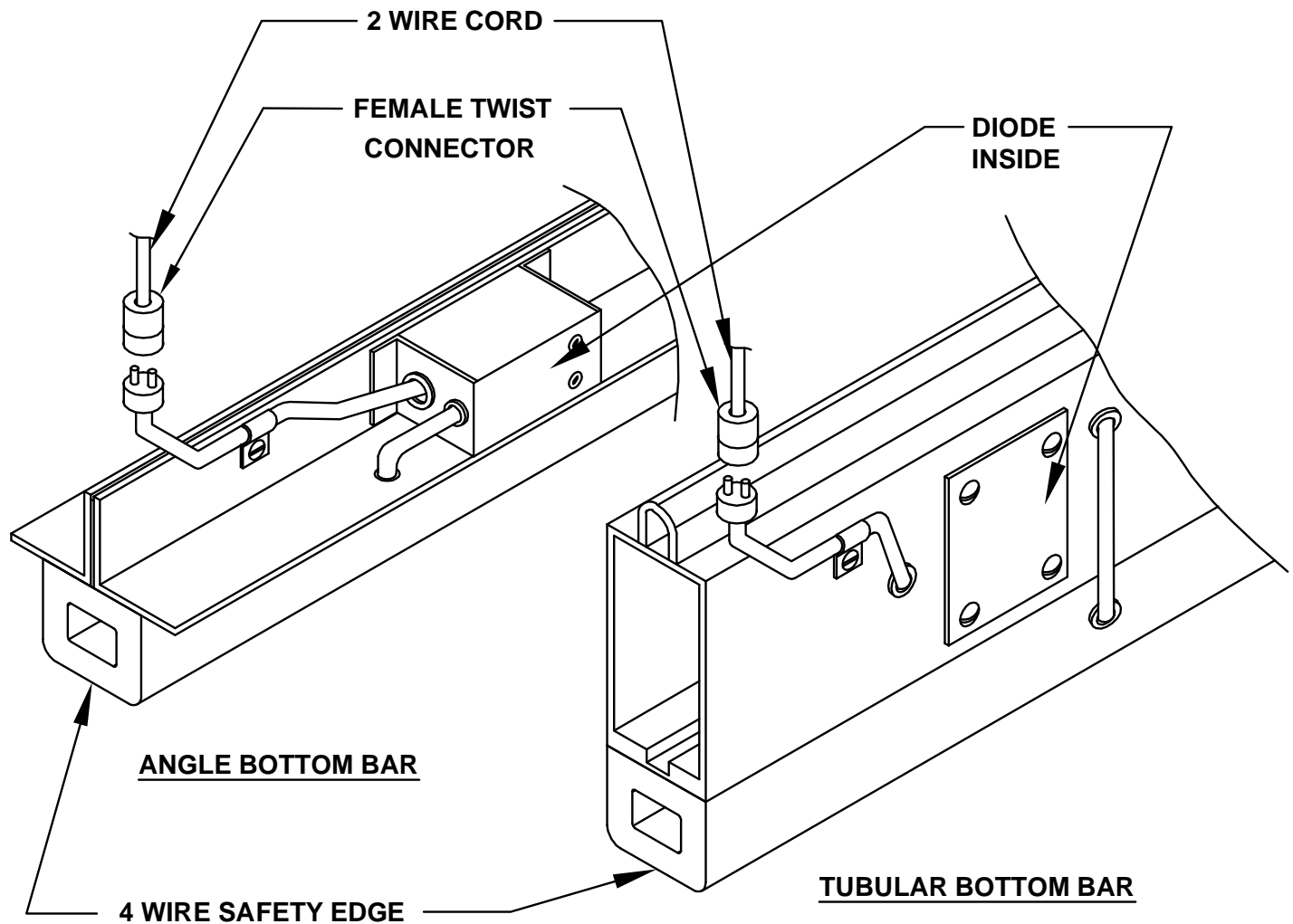

FIG 41

SETTING INSTRUCTIONS FOR FEATHEREDGE SWITCH

The Featheredge switch has been factory preset for normal operation from the supplier. The factory preset setting is 0.3mm to 0.4mm contact opening. Adjustment of the switch is not necessary unless operation will be under extremely unusual circumstances.

ALTERATION OF THE FACTORY PRESET SWITCH

- 1) Connect a multimeter/continuity tester (Ohm range) to the contact connectors on the switch.
- 2) Turn contact screw in a clockwise direction until contact is achieved.
(Contact opening = 0.0mm)
- 3) Turn the contact screw in a counter clockwise direction until the desired contact distance is reached. Scale division on the switch is: 1 Sub marking = 0.1mm of contact opening (Factory = 0.3mm to 0.4mm). The closer the setting is to 0.0mm, the more sensitive the switch becomes.

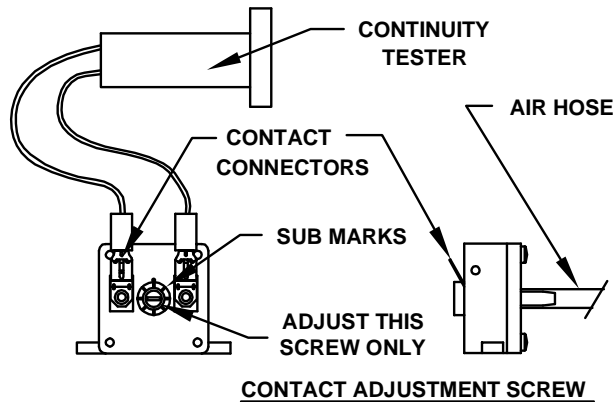

FIG 42

TOP SAFETY LIMIT SWITCH INSTALLATION

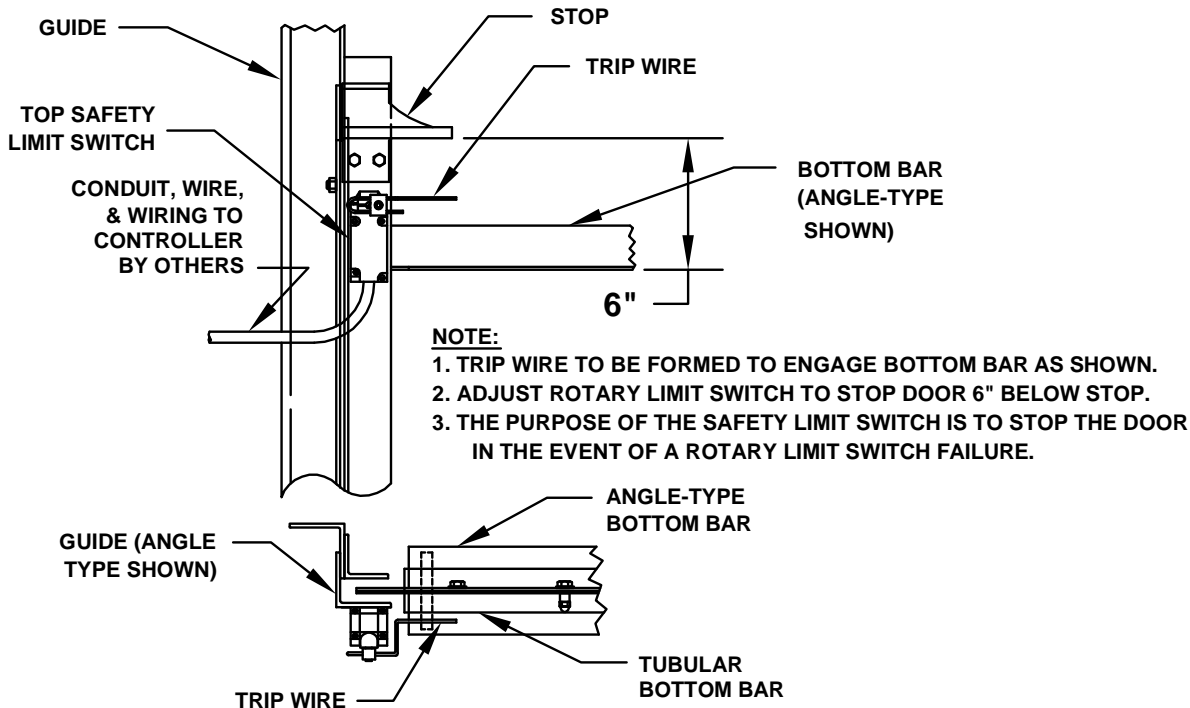
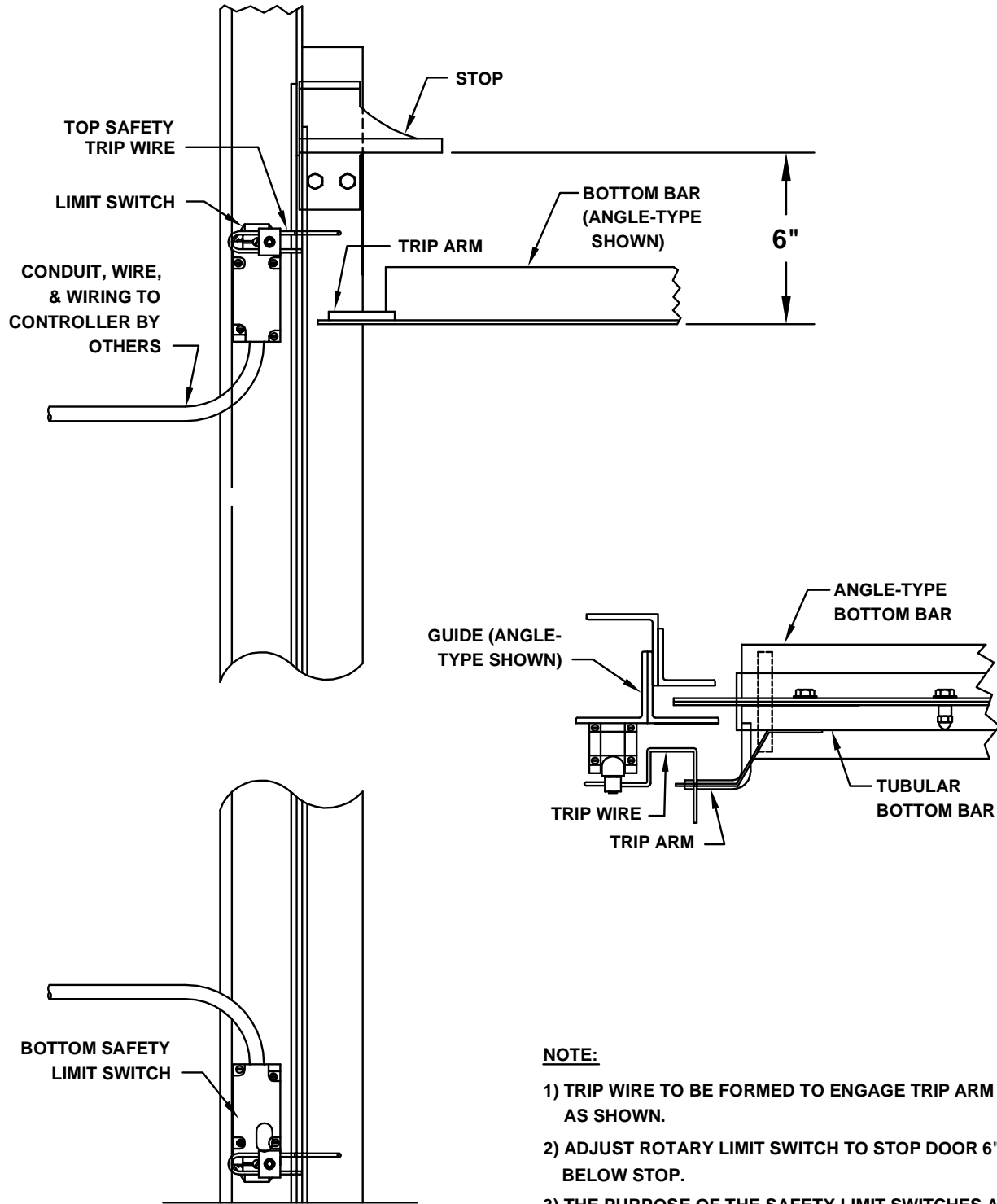

FIG 43

TOP AND BOTTOM SAFETY LIMIT SWITCH INSTALLATION



NOTE:

- 1) TRIP WIRE TO BE FORMED TO ENGAGE TRIP ARM AS SHOWN.
- 2) ADJUST ROTARY LIMIT SWITCH TO STOP DOOR 6" BELOW STOP.
- 3) THE PURPOSE OF THE SAFETY LIMIT SWITCHES ARE TO STOP THE DOOR IN THE EVENT OF A ROTARY LIMIT SWITCH FAILURE.

FIG 44

BRUSH TYPE GASKETING INSTALLATION INSTRUCTION

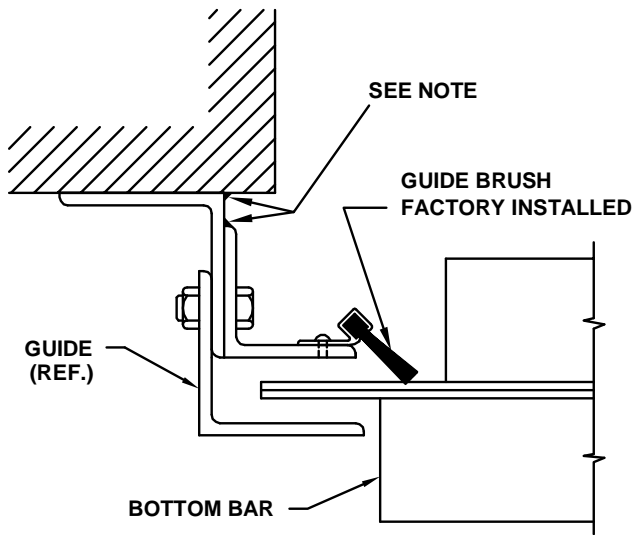

JAMB GASKET
(SHIP MOUNTED ON GUIDES)

FIG 45

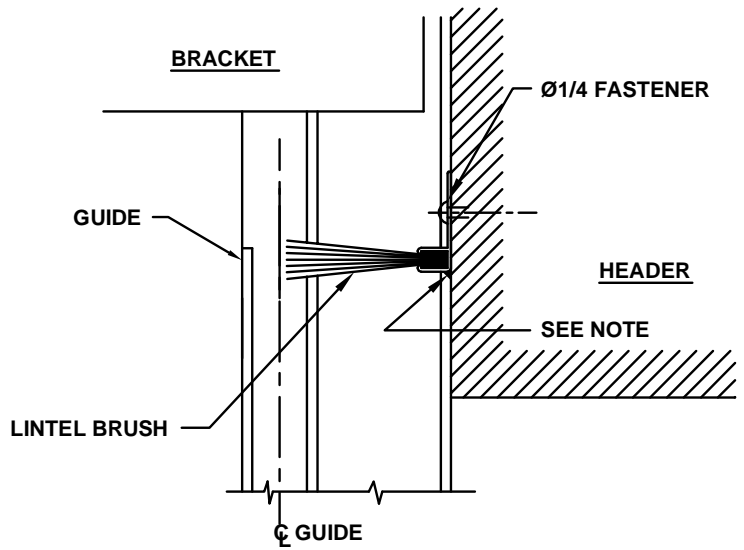

LINTEL GASKET

FIG 46

NOTE: FOR LEAKAGE RATED **S** LABELED DOORS, APPLY 1/8" MINIMUM APPROVED RTV CAULKING (PROVIDED)

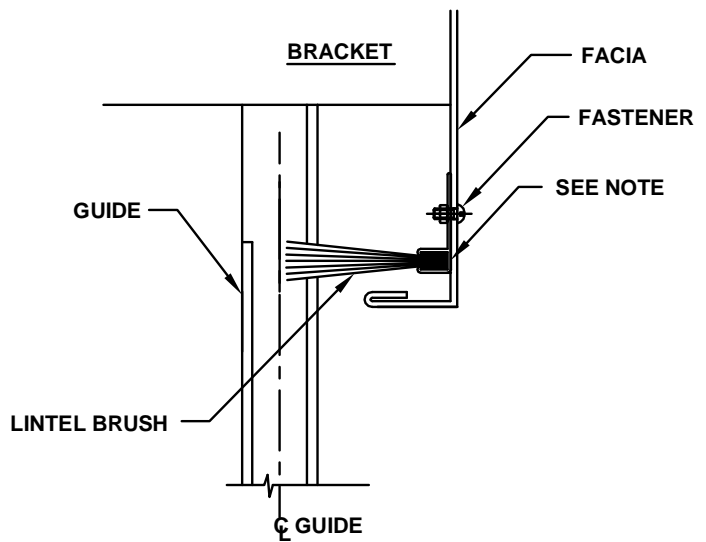

OPTIONAL FACIA MOUNTING

FIG 47

ELECTRICAL CONNECTIONS FOR FD-2A TO ALARM SYSTEM/SMOKE DETECTORS

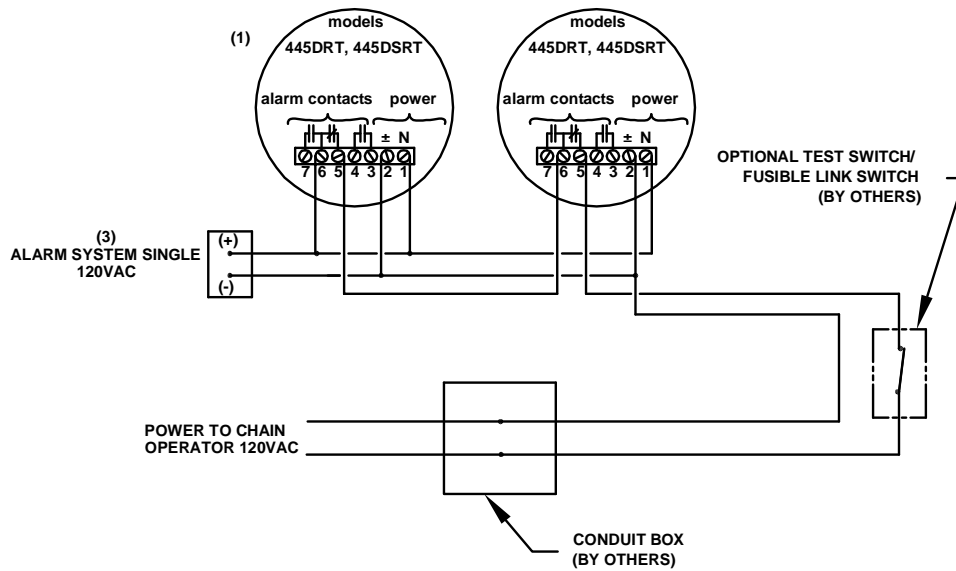

CAUTION:

DISCONNECT POWER BEFORE WORKING ON CIRCUIT!!

NOTES:

INSTALLATION INSTRUCTIONS MUST BE FOLLOWED TO ASSURE PROPER INSTALLATION.

- 1) See NFPA 80 and NFPA 72-1993 for proper placement of detector.
- 2) All external wiring is by others.
Minimum wire size = 14GA.
- 3) **WIRE TO 120VAC ALARM VOLTAGE ONLY!!**

FIG 48